690 Chesterfield Pkwy W • Chesterfield MO 63017-0760
Phone: 636-537-4000 • Fax 636-537-4798 • www.chesterfield.mo.us

Architectural Review Board Staff Report

Meeting Date: March 14, 2024

From: Isaak Simmers, Planner 

Location: 18305 Edison Ave

Description: **Spirit of St. Louis Airpark, Lot 19 (AVMATS Hangar):** An Amended Site Development Section Plan, Landscape Plan, Lighting Plan, Amended Architectural Elevations, and Architects Statement of Design for a 4.93-acre leasehold area within a 9.45-acre tract of land zoned “M-3” Planned Industrial District located north of Edison Avenue just east of its intersection with N Bell Avenue and approximately 700 feet west of its intersection with Spirit of St. Louis Boulevard (Ward 4).

PROPOSAL SUMMARY

Stock and Associates Consulting Engineers, Inc., on behalf of Centurion Investments, Inc., has submitted an Amended Site Development Section Plan, Landscape Plan, Lighting Plan, Amended Architectural Elevations, and Architects Statement of Design for a proposed expansion of the existing hangar in addition to modifications to the site’s circulation and parking area.



Figure 1: Subject Site

SITE HISTORY

The site was zoned “M-3” Planned Industrial for Spirit of St. Louis Airport via ordinance 2212 prior to the incorporation of the City of Chesterfield and remained undeveloped. The current ordinance governing the site is [Ordinance 1430](#). A Site Development Section Plan, Landscape Plan, Lighting Plan, and Architectural Elevations were reviewed by the Architectural Review Board in August, 2018 and the Board made a recommendation for approval with the following conditions:

- Differentiation in color to the office and hangar buildings;
- Soften the color of the proposed man doors and hangar door to match the field or similar color palette;
- Additional landscaping to the west elevation to carry around from the office area to the mechanical units.

The Site Development Section Plan was ultimately approved by Planning Commission in October, 2018. Power of Review was called with concerns over the voice vote being 5 to 2, but was ultimately rescinded following further discussion between Council and the applicant’s engineer.

STAFF ANALYSIS

The subject site consists of an existing 45,000SF office / warehouse and hangar facility located on the north side of Edison Ave just east of its intersection with N Bell Avenue. The location of the existing hangar, Hangar 40, is directly adjacent to an airport taxiway and the building entrance is facing the frontage along Edison Avenue. The applicant is proposing a 48,000SF expansion of the existing structure to the east referred to as Hangar 45. Proposed Hangar 45 is broken up into two sections; a lower section, shorter in elevation, colored “Medium Gray” which will include a drive-in door, and a larger section, taller in elevation, colored “Fox Gray” which will include the hangar door on the north elevation.

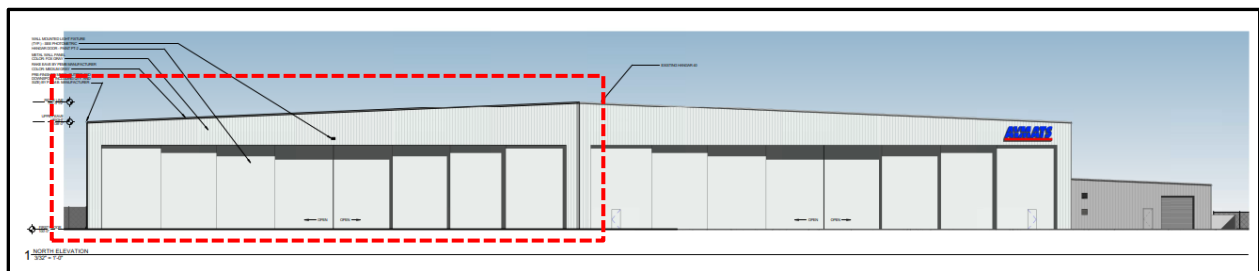

Figure 2: North Elevation, proposed indicated in red

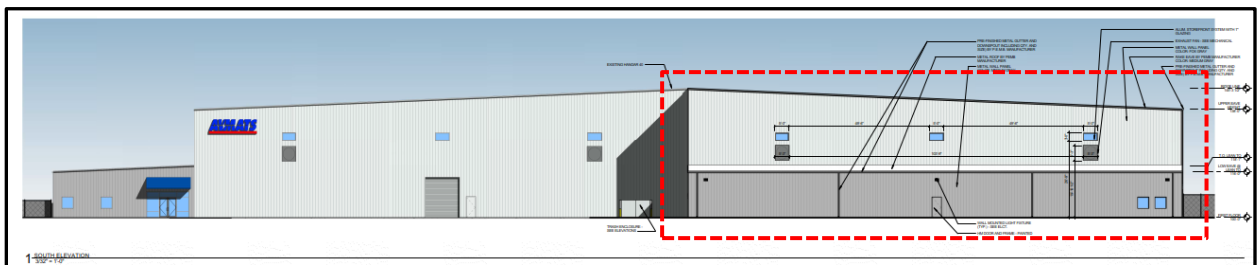

Figure 3: South Elevation, proposed indicated in red

Circulation System & Access

The subject site has one existing access on Edison Avenue. The proposed modifications include widening the existing access from thirty (30) feet to sixty (60) feet. In order to create the illusion of two separate access locations, painted striping will be incorporated as seen outlined in red in Figure 4. The design is to ensure the sixty (60) foot throat depth requirement is met at both entrances while allowing the space needed for the transportation of airport equipment and allow access to taxiways on the left and right sides of the parking area.

The proposed plan also includes the relocation of an existing screened trash enclosure to the northeast corner of the parking lot, seen outlined in blue.



Figure 4: Proposed Access and Circulation

Topography & Parking

The natural topography of the site is relatively level and the applicant has not proposed the use or need for any site retaining walls. The proposed modifications to the parking area include a total of fifty-five (55) parking spaces on site in lieu of the maximum allowed sixty-eight (68) spaces. Per code requirements, office / warehouse (hangar) requires two (2) spaces for every three (3) employees on the maximum shift. The applicant has provided the maximum number of employees to be forty (40) employees, therefore the site requires a minimum of forty-one (41) spaces. All proposed parking is located on the southern portion of the site between the front of the building and Edison Avenue. There are two pre-existing ADA parking stalls located near the front entrance and there are no additional ADA parking stalls proposed.

Scale & Design

Proposed Hangar 45 is scaled to match the architecture of the existing AVMATS Hangar building to which the expansion is connecting. As previously stated, the proposed hangar is broken up into two building masses. The larger mass will make up a majority of the expansion and has a maximum height of approximately forty-five feet and three and a half inches (45' 3 1/2"). This section of the expansion will have a hangar door along the north elevation. The smaller building mass has a maximum height of sixteen feet (16') and will extend further south than the existing office / hangar and be juxtaposed to the proposed parking area. The exterior of proposed Hangar 45 will be mainly comprised of Fox Gray metal wall panels with

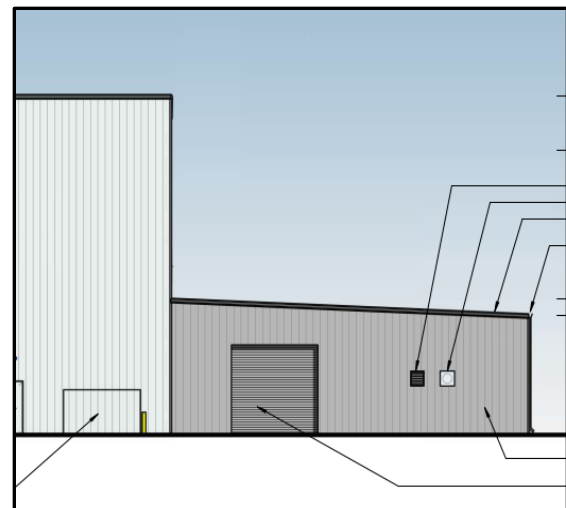

Figure 5: Partial West Elevation of Proposed Addition

pre-finished metal gutter and downspouts. The north façade will include an exhaust louver, and a wall mounted light fixture. The smaller building mass will be finished with Medium Gray metal wall paneling and will also include an exhaust louver, fan, and pre-finished overhead door along the west elevation (see Figure 5). The proposed construction will be comparable to the scale and design of surrounding structure around the airport.

Materials & Color

The proposed exterior materials include; Pre-Engineered Metal Building Panels in Fox Gray, Medium Gray, and white. The Heavy Metal Doors and Frames (overhead doors, and hangar doors) will match either Fox Gray or Medium Gray and is compatible with the existing structure. The gutters and downspouts will also match either Fox Gray or Medium Gray. The glass windows seen in the elevations will be clear with low-E coating.

RENDERING



Landscape Design & Screening

Spirit of St. Louis Airport requested that all landscaping at developments within the airport's vicinity be limited to features that would not serve as wildlife attractants. Per City requirements, the applicant must provide a letter from a certified tree specialist to request modifications to the City's landscape requirements. The applicant has provided a letter from the United States Department of Agriculture (USDA) Wildlife Services which is included in the packet. The USDA reviewed the landscaping plan that was initially provided to Staff and determined that all the proposed plant species could attract hazardous wildlife. The applicant has since submitted a landscape plan that proposed existing trees to be removed where they will interfere with construction and keep all other existing landscaping. No new landscaping is proposed.

The trash enclosure will be screened with pre-finished sight-proof metal ribbed paneling to match existing materials on site. Adjacent to the entrance of the trash enclosure will be two six inches

(6") in diameter steel, concrete filled pipe bollards painted yellow. There is existing chain linked screening on site which will be expanded for security of the proposed expansion.

Lighting

The applicant has provided a site photometric plan and fixture cut sheets per code requirements. Site lighting was installed when the site was initially developed and all proposed fixtures have been chosen to be compatible with what is existing on site. The maximum footcandle (fc) on site is 7.3 fc is lieu of the maximum allowed 8.0 fc for commercial development per code requirements. All proposed parking is illuminated and all proposed fixtures will not exceed the maximum allowed height of twenty feet (20').

DEPARTMENT INPUT

Be advised, this project is still going through development review by the City Staff and will not proceed to the Planning Commission until all outstanding items have been addressed. All recommendations made by the Architectural Review Board will be included in Staff's report to the Planning Commission.

Staff requests review on an Amended Site Development Section Plan, Landscape Plan, Lighting Plan, Amended Architectural Elevations, and Architect's Statement of Design for a 4.93-acre leasehold area within a 9.45-acre tract of land zoned "M-3" Planned Industrial District located north of Edison Avenue just east of its intersection with N Bell Avenue and approximately 700 feet west of its intersection with spirit of St. Louis Boulevard, Lot 19 (AVMATS Hangar).

MOTION

The following options are provided to the Architectural Review Board for consideration relative to this application:

"I move to forward the Amended Site Development Section Plan, Landscape Plan, Lighting Plan, Amended Architectural Elevations, and Architect's Statement of Design for Spirit of St. Louis Airport, Lot 19 (AVMATS Hangar) as presented, with recommendation for approval (or denial) to the Planning Commission."

"I move to forward the Amended Site Development Section Plan, Landscape Plan, Lighting Plan, Amended Architectural Elevations, and Architect's Statement of Design for Spirit of St. Louis Airport, Lot 19 (AVMATS Hangar) to the Planning Commission with a recommendation for approval with the following recommendations..."

Attachments

1. ARB Application
2. Applicant's Statement of Design and Intent
3. Landscape Hazards Letter (STL Airport / USDA)
4. ARB Submittal



March 6, 2024

Architectural Review Board
City of Chesterfield
Planning Department
690 Chesterfield Parkway West
Chesterfield, Missouri 63005

ACI BOLAND ARCHITECTS
17107 Chesterfield Airport Road, Suite 110
Chesterfield, Missouri 63005
T.314.991.9993

Re: AVMATS Hanger Expansion - Chesterfield, Missouri
ACI Boland Architects Project No. 2-23064

To City of Chesterfield – Planning Department:

We are pleased to submit the following project to The City of Chesterfield Architectural Review Board for their consideration. We have included in this Statement of Design listed below regarding how we plan to address each of the pertinent design standards as part of the design submittal requirements.

STATEMENT OF DESIGN INTENT

General Requirements for Site Design

Site Relationship

The 4.9 acre leasehold area contains an existing one story, 45,000 square foot building used as an office/warehouse and hangar. This proposal sets out to add a 48,000 square foot expansion at the East side of the existing building. This expansion will be used as additional hangar and storage space along with breakroom and restrooms. To the West of the property are existing hangars and to the East are existing office/warehouse buildings which front Spirit of St. Louis Blvd. Site access for the proposed building addition will be located on Edison Avenue, as illustrated by the Site Development drawings. The site has very little to no slope with existing trees and shrubs at the South and West sides of the existing building. Additional trees and plantings that comply with FAA regulations are included with this proposal. The adjacent properties to the West have very few trees or shrubs.

Circulation System and Access

The site is accessed off Edison Avenue and contains automobile parking in the front and a tarmac at the rear of the building with access to the taxi-ways. The vehicle entrance at the south is divided into two separate entrances with an overall width of approximately 60'. Existing landscaping will be supplemented with additional FAA compliant landscaping along the South Elevation to assist in screening the building from the street. Any required Mechanical and Electrical equipment will be placed on the East side of the proposed building and will be screened with FAA compliant landscaping. Located on the South side of the property, the trash dumpster will also be screened with a painted 6' high split face CMU and prefinished metal coping cap with composite or vinyl swinging gates and further veiled with additional FAA complaint landscaping. The visitor and employee parking is located near the entrance of the development along the fronts of the buildings. The accessible parking spaces are located along the front of the existing building allowing easy and safe access without needing to cross any drive lanes.

Topography

The natural topography is relatively level. Existing swales are located to the North, West, and South for

storm water management. We are following Spirit of St. Louis Airport regulations for bio-retention requirements.

Retaining Walls

We are not proposing the use or need for any site retaining walls at this time.

General Requirements for Building Design

Scale

The one story building is appropriately scaled to match the architecture of the existing AVMATS Hangar building to which this is connecting. To break down the scale of the building, the roof of the lean-to which houses the Storage and Breakroom/Restroom components has been brought down to a lower eave height to match the existing building. Windows are located on the South Elevation of the hangar to provide natural lighting into the hangar as well as articulation to the building facade.

Design

The building is designed to complement the other surrounding airport support buildings, but not overwhelm the existing AVSMATS Jet Support main headquarters which is located less than a quarter mile West of this building.

Materials and Colors

The materials on the building include two colors for the ribbed metal panels (a light and a dark), painted hollow metal doors, hangar doors, and overhead doors, one color standing seam metal roof, clear aluminum storefront windows with blue tinted glazing. The gutter, downspouts and trim will match the metal panels of the building.

Please refer to the exterior rendering and the larger material samples to be submitted at the Architectural Review Board meeting.

Landscape Design and Screening

The site has been carefully landscaped with trees and other shrubs/plantings to complement the existing landscape design, building scale and reduce the impact of the parking area and building to Edison Road. The required number of trees and shrubs has been provided and have been located to provide shade at strategic points while presenting visually pleasing vignettes to vehicular traffic and a beautiful buffer between the building and the street.

The plant palette, designed for low maintenance, has been selected from Chesterfield's list of approved trees. The chosen plants also provide pollinators and seasonal color & texture throughout the site as designed by the Landscape Architect.

We have also been advised by the USDA in cooperation with the FAA to eliminate certain plants that "produce seeds, fruit, or berries, or that provides dense roosting or nesting cover should not be used." This has also been taken into account for our submitted landscape plan.

Please refer to the submitted Landscape Plan and USDA letter for more information.

City of Chesterfield
ACI Boland Architects Project No. 2-23064
March 6, 2024
Page 3

Signage

We understand that signage review is not part of this process and will be reviewed at a later date once the owner has selected signage for their building. Any signage submitted at that time will be designed to meet the City of Chesterfield Code.

Lighting

The site lighting has been carefully designed. See the submitted lighting plan and the referenced fixture cut-sheets for your reference.

Once again, we are please to be continuing our relationship with the City of Chesterfield through the development of your wonderful city. If should need any additional information or have questions, please feel free to call me.

Respectfully Submitted,

ACI Boland Architects

A handwritten signature in black ink, appearing to read 'Kristopher T. Mehtens', with a long, sweeping horizontal stroke at the end.

Kristopher T. Mehtens
Senior Associate | Architect

Attachments:

City of Chesterfield – Architectural Review Board Project Statistics and Checklist

Sam Page
County Executive

John D. Bales, C.M.
Director of Aviation

SPIRIT

Of St. Louis
Airport

SINCE 1964

**Business Aviation
Center of the U.S.**

December, 2023

Stock & Associates, Inc.
Attn.: Joseph Fischer
257 Chesterfield Business Parkway
Chesterfield, MO 63005

RE: AVMATS Hangar 45

Dear Mr. Fischer,

The Airport has reviewed sheets SD-1, SD-2, L1.01, LC-1 plus building exterior elevations submitted yesterday as the Site Development Section Plan for the above referenced project. The plants listed in the planting schedule on sheet L1.01 all serve as wildlife attractants, and we therefore request they be eliminated or replaced with non-fruit/seed bearing alternatives. See the attached letter from the Airport's director for more information on the matter.

The Airport also requests copies of all FAA form 7460 determinations once analysis has been completed.

We do not object to the width of the proposed parking lot entrance at the Edison curb line and believe it will be beneficial to future airport operations as the potential starting point for an access road to the northern portions of the airport, keeping fuel and maintenance vehicles off the public streets.

Feel free to call should you need further information.

Sincerely,

SPIRIT OF ST. LOUIS AIRPORT

Justin Ryder
Airport Engineer



Digitally signed by
Justin Ryder
Date: 2023.12.05
14:40:07-06'00'

CC John D. Bales, CM, Director of Aviation
David Schubert, Deputy Director of Aviation



Sam Page
County Executive

John D. Bales, C.M.
Director of Aviation

SPiRiT

**Of St. Louis
Airport**

SINCE 1964

**Business Aviation
Center of the U.S.**

December 1, 2023

**RE: Spirit of St. Louis Airport
Chesterfield, Missouri
Wildlife Management at Spirit of St. Louis Airport**

To whom it may concern:

This letter is to address potential safety hazards created by certain types of landscaping features in and around Spirit of St. Louis Airport.

The Federal Aviation Administration (via FAA regulation subsection 139.337 and AC 150/5200-33C) makes it the responsibility of airport operators to minimize the chances of aircraft strikes with wildlife, both on the ground and in the air. One method is by controlling the amount and types of landscaping around the airport that could attract wildlife. Examples of landscape features that act as wildlife attractants include: water features, dense hedges, fruit and seed bearing trees, tall grasses, etc.

Therefore, the Spirit of St. Louis Airport requests that landscaping at developments within the airport's vicinity be limited only to the sorts of features that will not serve as an attractant to wildlife. Examples of this might include: decorative gravel, turf grasses, etc.

Thank you for your cooperation and please call, should you have any questions.

Sincerely,

SPIRIT OF ST. LOUIS AIRPORT



John D. Bales
Director of Aviation

CC David J. Schubert, Deputy Director of Aviation





United States
Department of
Agriculture

Animal and Plant
Health Inspection
Service

Wildlife Services

18004 Edison Ave.
Chesterfield, MO 63005
816-602-0672 (office)

February 22nd, 2024

To whom it may concern

USDA Wildlife Services staff have reviewed the landscaping proposal and determined that all the proposed plant species listed in the planting schedule could attract hazardous wildlife. Per AC 150/5200-33C (Section 2.8.2.1), "Vegetation that produces seeds, fruits, or berries, or that provides dense roosting or nesting cover should not be used".

Furthermore, the plant species in the proposed landscaping, particularly the tree and shrub selections, are known attractants to many of the bird species responsible for the majority of bird strikes indicated in the KSUS strike record. Black Gum of any variety provides roosting habitat, while also producing large amounts of attractive fruit desirable to birds during certain times of year. Junipers, Boxwoods, and tall ornamental grasses provide roosting/loafing opportunity and thermal cover for a variety of hazardous wildlife. Vegetative cover at airports should consist mostly of turf grasses whenever possible. In our region, endophyte infected fescues are generally the most suitable choice for our climate while minimizing any attractiveness to wildlife.

Dan Durbin
USDA Wildlife Services



APHIS Protecting American Agriculture
Equal Opportunity Employer

DANIEL DURBIN

Digitally signed by DANIEL
DURBIN
Date: 2024.02.22 14:23:19
-06'00'



VIEW LOOKING NORTHWEST



VIEW LOOKING NORTH



VIEW LOOKING SOUTHWEST

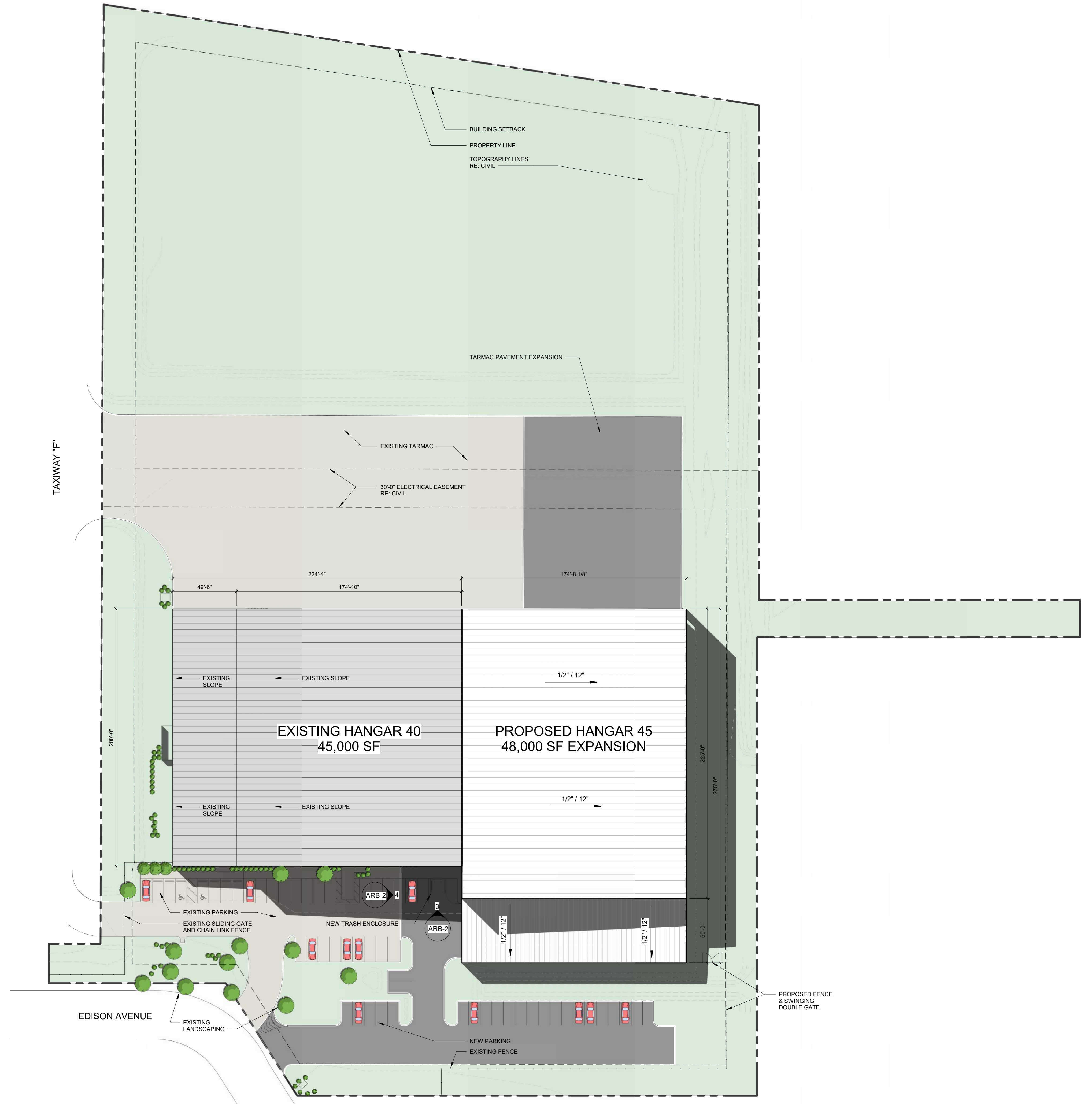

OVERALL SITE PLAN
1" = 40'-0"

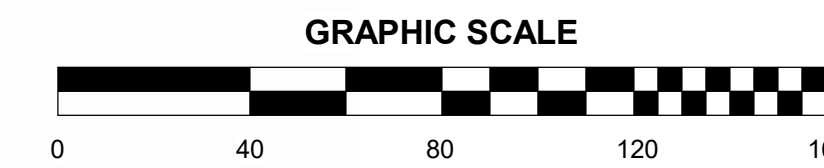

VIEW LOOKING NORTHEAST



VIEW LOOKING EAST



VIEW LOOKING SOUTH

3 TRASH ENCLOSURE GATE ELEVATION
3/32" = 1'-0"

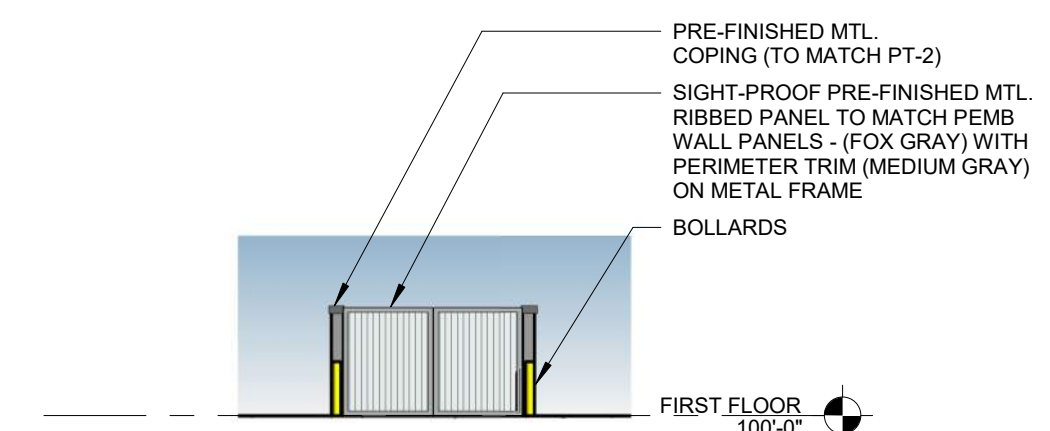

4 TRASH ENCLOSURE SIDE ELEVATION
3/32" = 1'-0"

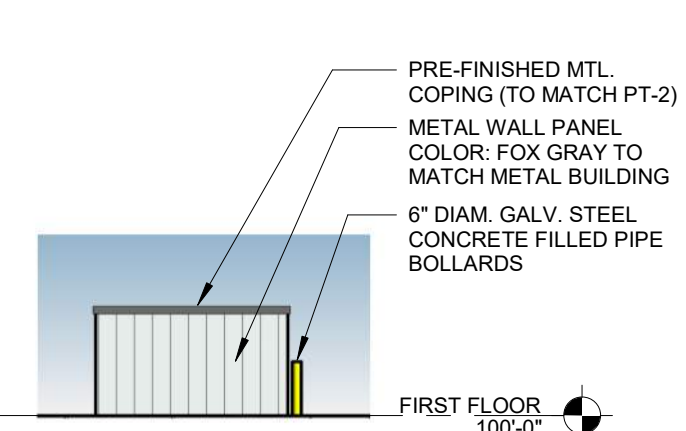

5 HINGE DETAIL
1 1/2" = 1'-0"

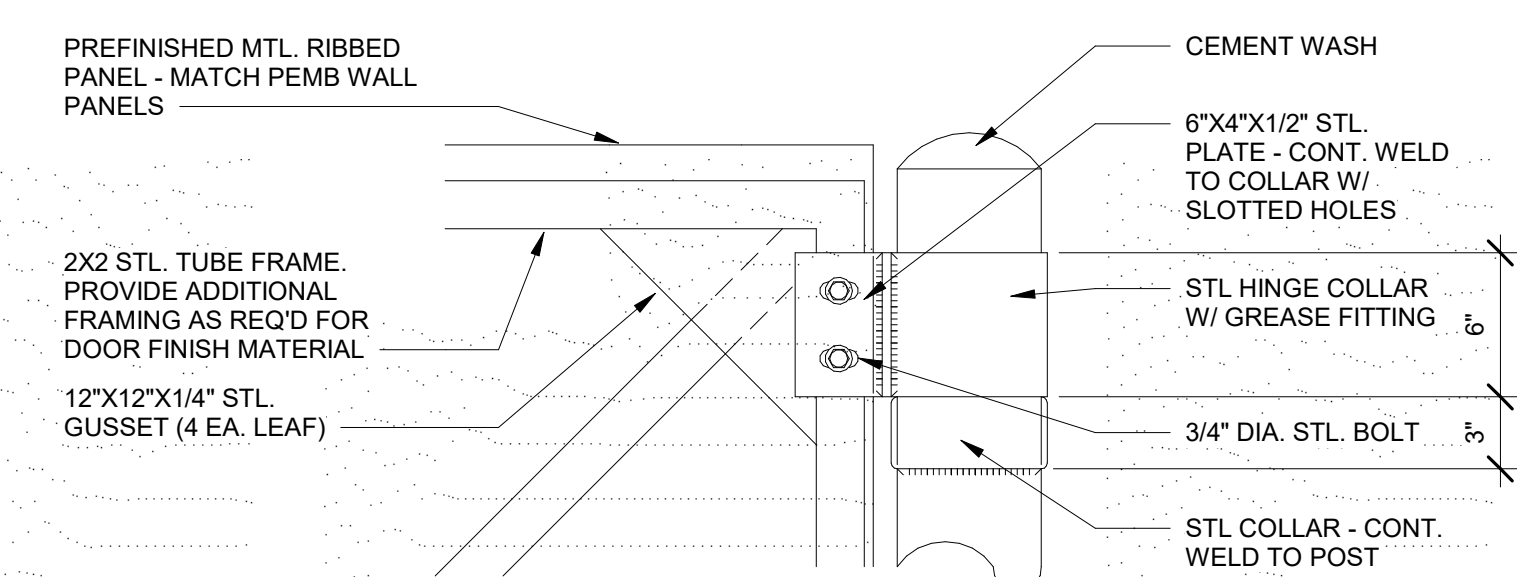

EXTERIOR MATERIAL LEGEND
(BASIS OF DESIGN)

Pre-Engineered Metal Building Panels (Warehouse)	Fox Gray
Pre-Engineered Metal Building Panels (Storage/Break)	Medium Gray
Pre-Engineered Metal Building Panels (Roof)	White
HM Doors & Frames, Overhead Doors, and Hangar Door	PT-1 Match Fox Gray PT-2 Match Medium Gray
Aluminum Storefront	4 1/2" X 2" Thermally Broken Storefront System - Firestone Ultra-Clad, Kynar 500/Fluor 2000 - Anodized Aluminum
Glass	Clear with Low-E Coating
Gutters and Downspouts	PT-1 Match Fox Gray PT-2 Match Medium Gray

1 NORTH ELEVATION
3/32" = 1'-0"

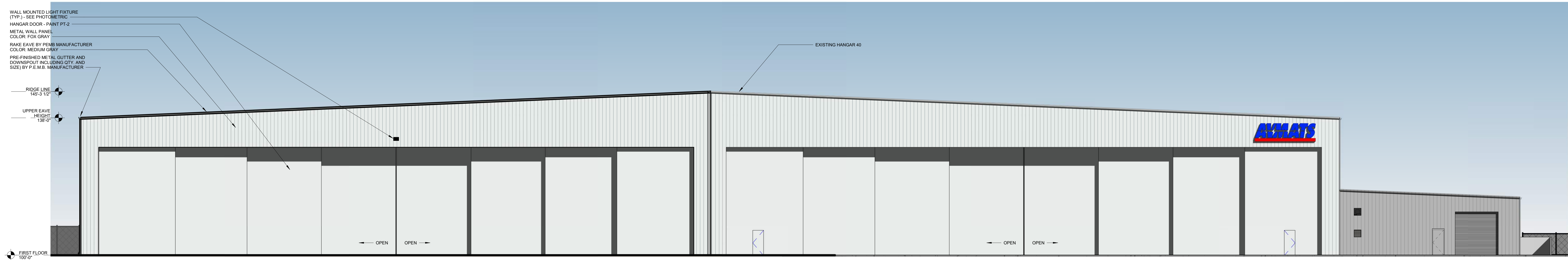

2 EAST ELEVATION
3/32" = 1'-0"

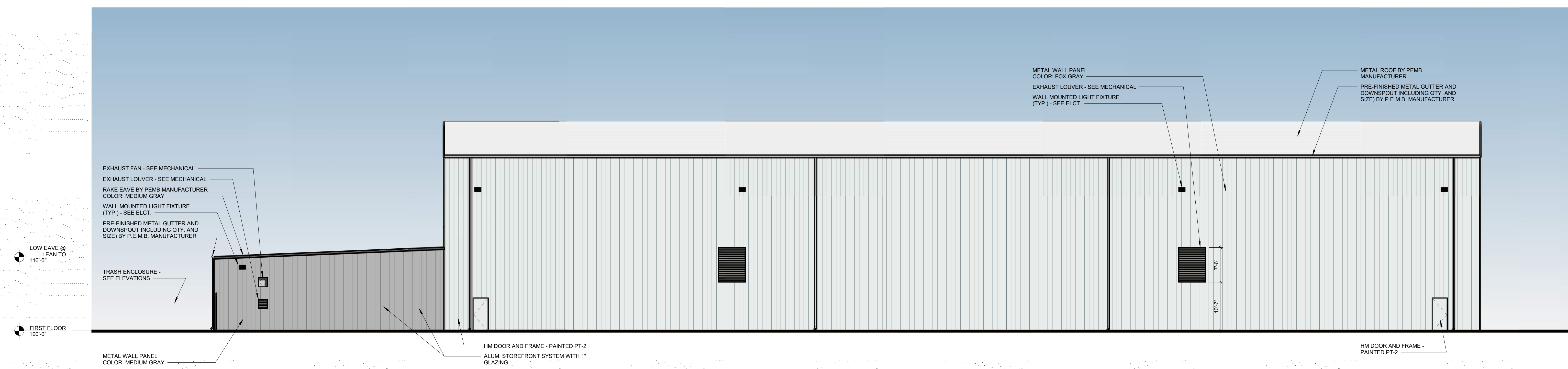

EXTERIOR MATERIAL LEGEND
(BASIS OF DESIGN)

Pre-Engineered Metal Building Panels (Warehouse)	Fox Gray
Pre-Engineered Metal Building Panels (Storage/Break)	Medium Gray
Pre-Engineered Metal Building Panels (Roof)	White
HM Doors & Frames, Overhead Doors, and Hangar Door	PT-1 Match Fox Gray PT-2 Match Medium Gray
Aluminum Storefront	4 1/2" X 2" Thermally Broken Spirefront System - Firestone Una-Clad, Kynar 500/nylon 2000 - Anodized Aluminum
Glass	Clear with Low-E Coating
Gutters and Downspouts	PT-1 Match Fox Gray PT-2 Match Medium Gray

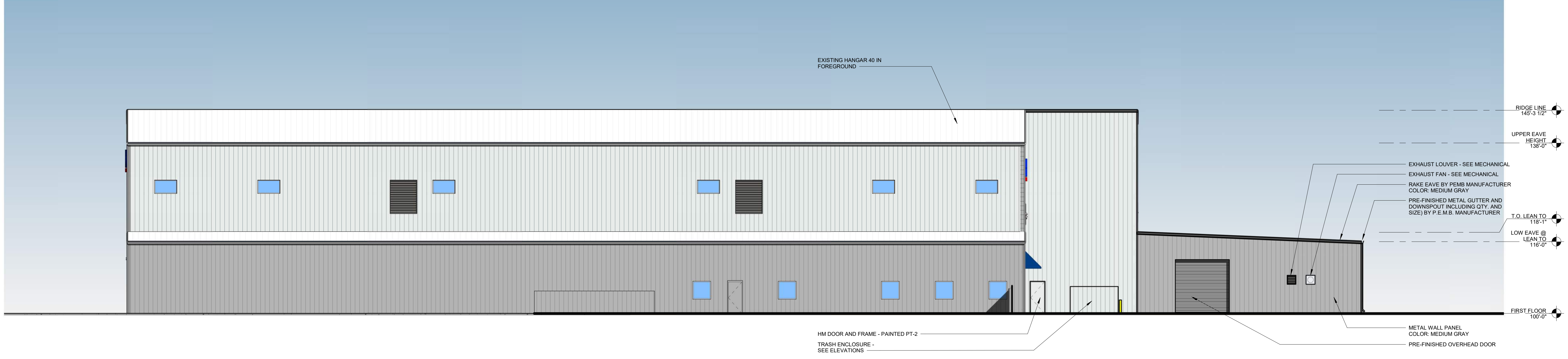

2 WEST ELEVATION
3/32" = 1'-0"

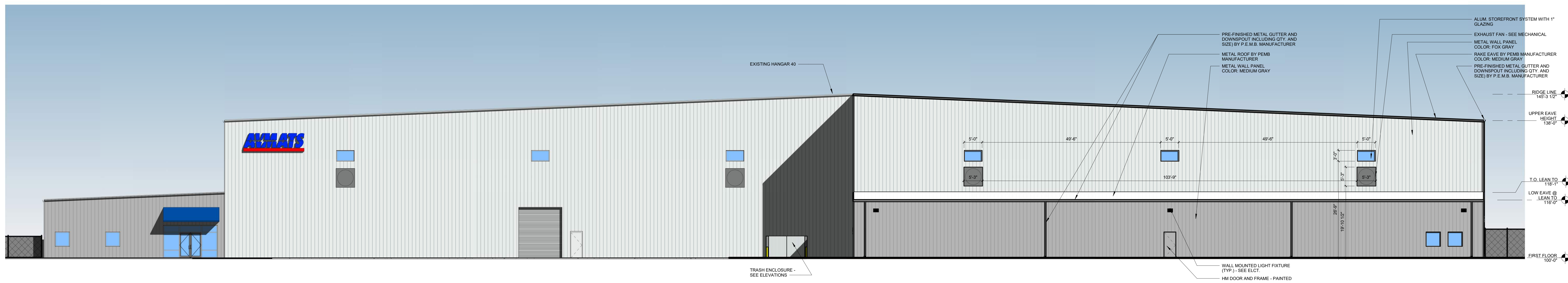

1 SOUTH ELEVATION
3/32" = 1'-0"



AVMATS
18301 Edison Avenue
Chesterfield, MO

17107 Chesterfield Airport Road | Suite 110
Chesterfield, Missouri 63005





PERSPECTIVE RENDERING
6" = 1'-0"

SITE DEVELOPMENT SECTION PLAN HANGAR 45

GENERAL NOTES

- BOUNDARY AND TOPOGRAPHICAL SURVEY BY STOCK AND ASSOCIATES CONSULTING ENGINEERS, INC. (BASIS OF BEARING: MISSOURI STATE PLANE, GRID NORTH)
- GRADING & STORM WATER PER THE CITY OF CHESTERFIELD, THE ST. LOUIS COUNTY DEPARTMENT OF HIGHWAYS AND TRAFFIC AND MSD.
- SUBJECT PROPERTY LIES WITHIN FLOOD ZONE "X" (AREAS WITH REDUCED FLOOD RISK DUE TO LEVEE, BASE FLOOD ELEVATIONS 459 FEET) ACCORDING TO THE NATIONAL FLOOD INSURANCE PROGRAM FLOOD INSURANCE RATE MAP FOR THE ST. LOUIS COUNTY, MISSOURI AND INCORPORATED AREAS. THIS MAP IS IDENTIFIED AS MAP NO. 29189C0145 K WITH AN EFFECTIVE DATE OF FEB. 4, 2015.
- ALL UTILITIES SHOWN HAVE BEEN LOCATED BY THE ENGINEER FROM AVAILABLE RECORDS. THEIR LOCATION SHOULD BE CONSIDERED APPROXIMATE. THE CONTRACTOR HAS THE RESPONSIBILITY TO NOTIFY ALL UTILITY COMPANIES, PRIOR TO CONSTRUCTION, TO HAVE EXISTING UTILITIES FIELD LOCATED. SHOULD ANY CONFLICTS BE EVIDENT, THE CONTRACTOR SHALL NOTIFY THE OFFICE OF THE ENGINEER IMMEDIATELY.
- ARCHITECTURAL ELEVATIONS, SITE LANDSCAPING PLANS, SITE LIGHTING PLANS AND SITE SIGNAGE PLANS SHALL BE SUBMITTED TO THE CITY OF CHESTERFIELD AS INDIVIDUAL LOTS ARE DEVELOPED ON THEIR SITE DEVELOPMENT SECTION PLAN.
- ON-SITE STORM WATER DRAINAGE REQUIREMENTS SHALL BE IN ACCORDANCE WITH THE CHESTERFIELD VALLEY MASTER STORM WATER DRAINAGE PLAN AND AS DIRECTED BY THE CITY OF CHESTERFIELD.
- OFF-SITE GRADING EASEMENTS, IF REQUIRED, SHALL BE EXECUTED AND RECORDED PRIOR TO THE COMMENCEMENT OF ANY OFF-SITE GRADING.
- CROSS-ACCESS EASEMENTS WHERE REQUIRED, SHALL BE EXECUTED AND RECORDED AS INDIVIDUAL LOTS ARE DEVELOPED.
- PRIOR TO SPECIAL USE PERMIT ISSUANCE BY THE SAINT LOUIS COUNTY DEPARTMENT OF HIGHWAYS AND TRAFFIC, A SPECIAL CASH ESROW OR A SPECIAL ESROW SUPPORTED BY AN IRREVOCABLE LINE OF CREDIT, MUST BE ESTABLISHED WITH THE SAINT LOUIS COUNTY.
- ALL BUILDINGS AND ROADWAYS SHALL BE ELEVATED A MINIMUM 1 FOOT ABOVE THE MAX. HIGH-WATER ELEVATION AS ESTABLISHED BY THE FEMA MAP.
- ALL PROPOSED IMPROVEMENTS SHALL BE CONSTRUCTED TO ST. LOUIS COUNTY, M&DOT AND THE CITY OF CHESTERFIELD STANDARDS.
- ALL GRADING AND DRAINAGE TO BE IN CONFORMANCE WITH THE ST. LOUIS COUNTY, MSD AND CITY OF CHESTERFIELD STANDARDS.
- NO SLOPES WITHIN SAINT LOUIS COUNTY RIGHT-OF-WAY SHALL EXCEED 3 (HORIZONTAL) TO 1 (VERTICAL).
- STORM WATER SHALL BE DISCHARGED AT AN ADEQUATE NATURAL DISCHARGE POINT. SINHOLES ARE NOT ADEQUATE DISCHARGE POINTS.
- AN ELEVATION CERTIFICATE WILL NEED TO BE COMPLETED FOR ANY STRUCTURE LOCATED WITHIN THE SUPPLEMENTAL PROTECTION AREA (SPA) AS DEFINED BY SECTION 405.05, FLOOD DAMAGE PREVENTION, OF THE CITY CODE.
- A SIGN PACKAGE IS REQUIRED FOR THIS DEVELOPMENT AND MUST BE APPROVED BY THE PLANNING COMMISSION.
- LIGHT FIXTURES SHALL NOT EXCEED 20 FEET IN HEIGHT WHEN MOUNTED ON POLES.
- THE SITE IS ZONED M-3, PLANNED INDUSTRIAL DISTRICT WITH GOVERNING ORDINANCE NO. 1430. SETBACKS: FRONT YARD - 30 FEET
SIDE YARD - 10 FEET
REAR YARD - 10 FEET

LEGEND

EXISTING CONTOURS	--- 10' ---
PROPOSED CONTOURS	--- 10' ---
EXISTING SANITARY SEWERS	--- 10' ---
EXISTING STORM SEWERS	--- 10' ---
PROPOSED SANITARY SEWERS	--- 10' ---
PROPOSED STORM SEWERS	--- 10' ---
EXISTING RIGHT-OF-WAY	--- 10' ---
PROPOSED RIGHT-OF-WAY	--- 10' ---
CENTERLINE EASEMENT	--- 10' ---
NOTES PARKING SPACES	(18)
QUI WIRE	↑
EXISTING SPOT ELEVATION	• 62.1245
PROPOSED SPOT ELEVATION	• 62.1245
SWALE	---
TO BE REMOVED	T&R
TO BE REMOVED & RELOCATED	T&R & R
TO BE USED IN PLACE	U&P
BACK OF CURB	B.C.
FACE OF CURB	F.C.
TRASH ENCLOSURE	☒
EXISTING LIGHT STANDARD	☒
GAS MAIN	G
WATER MAIN	W
UNDERGROUND TELEPHONE	U
UNDERGROUND TELEPHONE	U

ABBREVIATIONS

W	WATER	DB	DEED BOOK
E	ELECTRIC	PB	PLAT BOOK
OE	OVERHEAD ELECTRIC	PG	PAGE
UE	UNDERGROUND ELECTRIC	C(W)	RIGHT-OF-WAY WIDTH
G	GAS	(REC)	RECORD INFORMATION
T	TELEPHONE	FT	FEET
TBR	TO BE REMOVED	N/F	NOW OR FORMERLY
TBR & R	TO BE REMOVED AND REPLACED	FND	FOUND
UP	USE IN PLACE	SO	SQUARE
ATG	ADJUST TO GRADE	CO	CLEANOUT
BC	BACK OF CURB	MH	MANHOLE
FC	FACE OF CURB	AI	AREA INLET
TR	TOP OF WALL	GI	GRATE INLET
BW	BOTTOM OF WALL	GI	GRATE INLET
PMAT	PAVEMENT	YD	YARD DRAIN
ASPH	ASPHALT	PVC	POLYVINYL CHLORIDE PIPE
CONC	CONCRETE	RCP	REINFORCED CONCRETE PIPE
GRND	GROUND	CMPC	CONCRETE METAL PIPE
FG	FINISHED GRADE	VCP	CLAY PIPE
FL	FINISHED FLOOR	FL	FLUMING
LL	LOWER LEVEL	TS	TAILSTAKE
TT	TOP OF TURF	ELEV. EL.	ELEVATION
TOP	TOP OF CURB	PROP. PR	PROPOSED
SG	SUBGRADE	EXIST. EX	EXISTING
MG	METHANE GAS	TYP.	TYPICAL
		BMP	BEST MANAGEMENT PRACTICES
		SWPPP	STORMWATER POLLUTION PREVENTION PLAN

BENCHMARK

SL-40: BRASS DISC STAMPED "SL-40, 1990" ON THE NORTH SIDE OF NORTH OUTER 40 RD, ACROSS FROM THE INTERSECTION OF SPIRIT OF ST. LOUIS SQUARE. ELEV.=486.55

SITE BENCHMARK

ELEV.=461.30
FND. IRON PIPE AT THE NORTHWEST CORNER OF SITE AS SHOWN HEREON.

ST. LOUIS COUNTY NOTES

FOR WORK PROPOSED WITHIN ST. LOUIS COUNTY RIGHT-OF-WAY (EDISON AVE.)

- ALL SIDEWALKS TO BE CONSTRUCTED TO SAINT LOUIS COUNTY ADA STANDARDS WITHIN ST. LOUIS COUNTY R/W.
- THE DEVELOPER IS REQUIRED TO PROVIDE ADEQUATE STORM WATER SYSTEMS IN ACCORDANCE WITH SAINT LOUIS COUNTY AND MSD STANDARDS.
- ALL GRADING AND DRAINAGE TO BE IN CONFORMANCE WITH SAINT LOUIS COUNTY AND MSD STANDARDS.
- NO SLOPES WITHIN ST. LOUIS COUNTY RIGHT-OF-WAY SHALL EXCEED 3 (HORIZONTAL) TO 1 (VERTICAL).
- STORM WATER SHALL BE DISCHARGED AT AN ADEQUATE NATURAL DISCHARGE POINT. SINHOLES ARE NOT ADEQUATE DISCHARGE POINTS.
- ALL WORK WITHIN ST. LOUIS COUNTY RIGHT-OF-WAY SHALL BE TO COUNTY STANDARDS.
- ALL DISTURBED EARTH AREAS WITHIN ST. LOUIS COUNTY RIGHT-OF-WAY SHALL BE SOLODED.
- INSTALLATION OF LANDSCAPING AND ORNAMENTAL ENTRANCE MONUMENT OR IDENTIFICATION SIGNAGE CONSTRUCTION, IF PROPOSED, SHALL BE REVIEWED BY THE DEPARTMENT OF HIGHWAYS AND TRAFFIC FOR SIGN DISTANCE CONSIDERATIONS AND APPROVED PRIOR TO INSTALLATION OR CONSTRUCTION.
- THE DEVELOPER IS ADVISED THAT UTILITY COMPANIES WILL REQUIRE COMPENSATION FOR RELOCATION OF THEIR FACILITIES WITHIN THE PUBLIC ROAD RIGHT-OF-WAY. ST. LOUIS COUNTY SHALL BEAR NO RESPONSIBILITY FOR UTILITY RELOCATION OR ADJUSTMENT COSTS OR ASSOCIATED DELAYS. UTILITY RELOCATION COST SHALL BE CONSIDERED THE DEVELOPER'S RESPONSIBILITY. THE DEVELOPER SHALL ALSO BE AWARE OF EXTENSIVE DELAYS IN UTILITY COMPANY RELOCATION AND ADJUSTMENTS. SUCH DELAYS WILL NOT CONSTITUTE A CAUSE TO ALLOW OCCUPANCY PRIOR TO COMPLETION OF ROAD IMPROVEMENTS.
- PROVIDE ADEQUATE OFF-STREET PARKING FOR CONSTRUCTION EMPLOYEES. PARKING ON NON-SURFACED AREAS SHALL BE PROHIBITED IN ORDER TO ELIMINATE THE CONDITION WHEREBY MUD FROM CONSTRUCTION AND EMPLOYEE VEHICLES IS TRACKED ONTO THE PAVEMENT CAUSING HAZARDOUS ROADWAY AND DROWAY CONDITIONS.
- ADDITIONAL SILATION CONTROL SHALL BE INSTALLED AS REQUIRED BY ST. LOUIS COUNTY DEPARTMENT OF HIGHWAYS AND TRAFFIC.
- PERMIT WILL BE REQUIRED BY ST. LOUIS COUNTY DEPARTMENT OF PUBLIC WORKS FOR CONSTRUCTION OF RETAINING WALLS.
- PERMIT WILL BE REQUIRED BY ST. LOUIS COUNTY DEPARTMENT OF PUBLIC WORKS FOR ROOF DRAIN CONNECTIONS.
- ALL OFFSITE PROPERTY OWNERS SHALL BE GIVEN NOTICE 48 HOURS IN ADVANCE OF ANY WORK.
- ANY DISTURBED OFF SITE PROPERTY (I.E. BUSHES, FENCES, MAILBOXES, ETC.) SHALL BE REPLACED, IN KIND, AT THE DEVELOPER'S EXPENSE.
- INTERNAL (PRIVATE) STORM SEWERS WILL REQUIRE A SEPARATE DRAINLAYER PERMIT FROM ST. LOUIS COUNTY DEPARTMENT OF PUBLIC WORKS.
- TREES AND/OR SHRUBS SHALL NOT BE REMOVED OR DISTURBED WITHIN ST. LOUIS COUNTY RIGHT-OF-WAY WITHOUT PRIOR APPROVAL OF THE ST. LOUIS COUNTY DEPARTMENT OF HIGHWAYS AND TRAFFIC.
- TRUCKS SHALL NOT EXCEED POSTED WEIGHT LIMITS FOR ST. LOUIS COUNTY BRIDGES DURING HAUL OPERATIONS.
- SEDIMENT SHALL BE WASHED FROM ALL VEHICLES AT WASHDOWN STATION PRIOR TO LEAVING SITE. NO TRACKING OF MUD ONTO COUNTY ROADS SHALL BE ALLOWED.
- INTERM STORM WATER DRAINAGE CONTROL IN THE FORM OF SILATION CONTROL MEASURES ARE REQUIRED.
- ALL CONSTRUCTION SHALL BE PER MOST CURRENT DETAILS LOCATED IN THE ST. LOUIS COUNTY DESIGN CRITERIA MANUAL AND/OR THE SEDIMENT AND EROSION CONTROL MANUAL.
- ALL HYDRANTS, POWER POLES OR OTHER OBSTRUCTIONS WITHIN ST. LOUIS COUNTY RIGHT-OF-WAY SHALL HAVE A MINIMUM TWO FOOT SETBACK FROM FACE OF CURB OR EDGE OF SKULLER OF THE ULTIMATE PAVEMENT SECTION AS DIRECTED BY ST. LOUIS COUNTY DEPARTMENT OF HIGHWAYS AND TRAFFIC.
- RIGHT-OF-WAY DEDICATION SHALL BE COMPLETED PRIOR TO THE ISSUANCE OF A SPECIAL USE PERMIT. ROAD IMPROVEMENTS SHALL BE COMPLETED PRIOR TO THE ISSUANCE OF AN OCCUPANCY PERMIT. IF DEVELOPMENT PHASING IS INDICATED, THE DEVELOPER SHALL COMPLETE ROAD IMPROVEMENTS, RIGHT-OF-WAY DEDICATION AND ACCESS REQUIREMENTS OF EACH PHASE OF DEVELOPMENT AS DIRECTED BY THE DEPARTMENT OF HIGHWAYS AND TRAFFIC. THE DELAYS DUE TO UTILITY RELOCATION AND ADJUSTMENTS WILL NOT CONSTITUTE A CAUSE TO ALLOW OCCUPANCY PRIOR TO COMPLETION OF ROAD IMPROVEMENTS.
- APPLICANT SHALL USE EXTREME CAUTION IN AREAS WHERE TRAFFIC SIGNAL FACILITIES ARE EXISTING. IT IS THE RESPONSIBILITY OF THE CONTRACTOR/DEVELOPER TO CONTACT THE ST. LOUIS COUNTY DEPARTMENT OF HIGHWAYS AND TRAFFIC AT (314) 615-0215 A MINIMUM OF 48 HOURS IN ADVANCE OF CONSTRUCTION WORK FOR LOCATING AND SPOTTING EXISTING TRAFFIC SIGNAL CONTROL. IN THE EVENT THE CONTRACTOR CHANGES ANY TRAFFIC SIGNAL FACILITIES, REPAIRS SHALL BE MADE AT THE CONTRACTOR'S EXPENSE BY AN ELECTRICAL CONTRACTOR AS DIRECTED BY ST. LOUIS COUNTY.
- THE CONTRACTOR SHALL NOTIFY THE ST. LOUIS COUNTY DIVISION OF OPERATIONS STRIPPING PERSONNEL AT (314) 615-0213, 24 HOURS IN ADVANCE OF ANY STRIPING RELATED WORK. ALL GRINDING OF EXISTING STRIPING AND INSTALLATION OF TEMPORARY STRIPING AS REQUIRED BY ST. LOUIS COUNTY SHALL BE PERFORMED BY THE CONTRACTOR. ALL PERMANENT STRIPING WILL BE INSTALLED BY THE ST. LOUIS COUNTY DEPARTMENT OF HIGHWAYS AND TRAFFIC.
- ANY ENTITY THAT PERFORMS WORK ON ST. LOUIS COUNTY MAINTAINED PROPERTY SHALL PROVIDE THE COUNTY WITH A CERTIFICATE OF INSURANCE EVIDENCING GENERAL LIABILITY COVERAGE (BODILY INJURY AND PROPERTY DAMAGE) IN THE AMOUNTS SPECIFIED AS THE LIMITS OF LIABILITY SET BY THE STATE FOR PUBLIC ENTITIES. SUCH CERTIFICATE SHALL INCLUDE ST. LOUIS COUNTY AS AN ADDITIONAL INSURED AND SHALL BE PROVIDED PRIOR TO THE ISSUANCE OF ANY PERMIT. CERTIFICATE SHALL PROVIDE FOR A 30 DAY POLICY CANCELLATION NOTICE TO ST. LOUIS COUNTY. UPON REQUEST, THE COUNTY WILL PROVIDE THE SPECIFIC AMOUNTS FOR BOTH PER PERSON AND PER OCCURRENCE LIMITS.
- ALL SIDEWALKS, SIDEWALK TERMINATIONS, AND ASSOCIATED ACCESSIBILITY IMPROVEMENTS SHALL BE CONSTRUCTED TO ST. LOUIS COUNTY ADA STANDARDS, WITHIN ST. LOUIS COUNTY R/W.
- PRIOR TO IMPROVEMENTS/CONSTRUCTION PLAN APPROVAL, THE ENGINEERS SHALL PROVIDE A SIGNED AND SEALED NOTE ON THE PLANS FOR BOTH RESIDENTIAL AND COMMERCIAL PROJECTS STATING THAT THE UNIMPROVED EXISTING SIDEWALK ALONG THE PROJECT FRONTAGE MEETS CURRENT ST. LOUIS COUNTY/ADA STANDARDS.
- SIDEWALK TERMINATIONS IN COMPLIANCE WITH ST. LOUIS COUNTY ADA STANDARDS SHALL BE PROVIDED.
- CONTINUOUS PEDESTRIAN ACCESS SHALL BE PROVIDED DURING THE CONSTRUCTION PROCESS. PRIOR TO THE START OF CONSTRUCTION, ADEQUATE PEDESTRIAN ACCESS AROUND THE SITE SHALL BE PROVIDED AND MAINTAINED. NO EXISTING SIDEWALK SHALL BE REMOVED WITHOUT PROVIDING ADEQUATE PEDESTRIAN FACILITIES AND ROUTES DURING CONSTRUCTION ACTIVITIES.
- MAXIMUM LEGAL LENGTHS IN THE COUNTY ARE FORTY (40) FEET FOR ANY SINGLE UNIT TRUCK AND FIFTY-FIVE (55) FEET FOR ANY COMBINATION OF VEHICLES, INCLUDING THE LOAD. MAXIMUM LEGAL WIDTH IS EIGHT (8) FEET AND MAXIMUM HEIGHT IS THIRTEEN AND ONE-HALF (13 1/2) FEET. LEGAL WEIGHT LIMITS IN THE COUNTY ARE THE SAME AS THOSE REQUIRED BY MISSOURI STATE LAWS, EXCEPT IN CASES WHEN THE COUNTY COUNCIL HAS ESTABLISHED ROADWAY LOAD LIMITS BY ORDINANCE OR WHEN BRIDGES ARE POSTED UNDER STATE REGULATIONS. ANY VEHICLES EXCEEDING THESE LIMITS SHALL REQUIRE A SPECIAL USE PERMIT FOR OVERWEIGHT AND/OR OVER-DIMENSION VEHICLES PRIOR TO DRIVING ON ST. LOUIS COUNTY ROADWAYS. CONTACT (314) 615-8517 FOR PERMITS.
- ALL STRIPING WITHIN COUNTY RIGHT-OF-WAY SHALL BE INSTALLED BY COUNTY FORCES.
- THE CONTRACTOR SHALL MAINTAIN EXISTING TRAFFIC CONTROL SIGNS (STREET NAME, STOP, NO PARKING, ONE WAY, TURN, ETC) UNTIL SUCH TIME AS THEY NEED TO BE REMOVED/RELOCATED FOR CONSTRUCTION OPERATIONS. TEMPORARY SIGNING SHALL BE IN ACCORDANCE WITH THE CURRENT VERSION OF MUTCD CHAPTER 6B (TEMPORARY TRAFFIC CONTROL ZONE DEVICES). EXISTING SIGNS SHALL NOT LIE ON THE GROUND FOR ANY PERIOD OF TIME. PORTABLE SUPPORTS SHALL NOT BE LOCATED ON SIDEWALKS OR AREAS DESIGNATED FOR PEDESTRIAN TRAFFIC. SIGNS SHALL BE CROSSLIGHTED AND PROPERLY MAINTAINED FOR CLEANLINESS, VISIBILITY, AND PROPER POSITIONING, AND SHALL BE COORDINATED WITH THE ST. LOUIS COUNTY SIGN SHOP AT (314) 615-0242.
- ACCESS TO ALL PROPERTIES SHALL BE MAINTAINED AT ALL TIMES DURING THE CONSTRUCTION PROCESS.

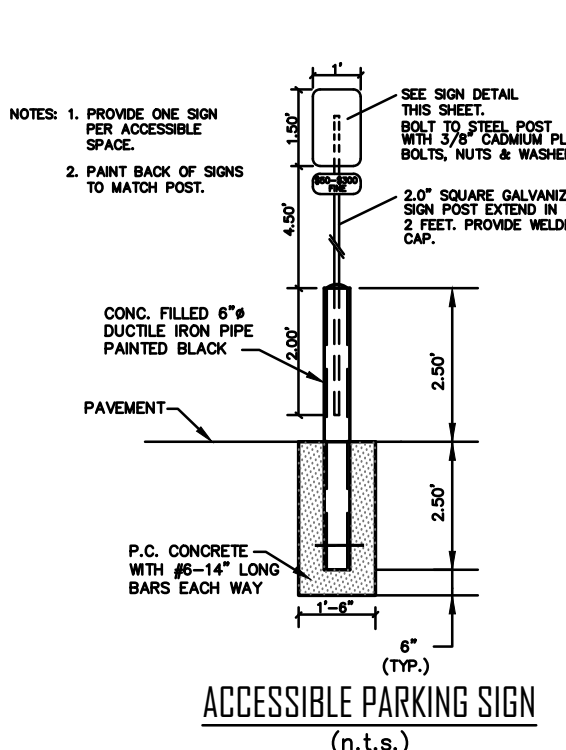
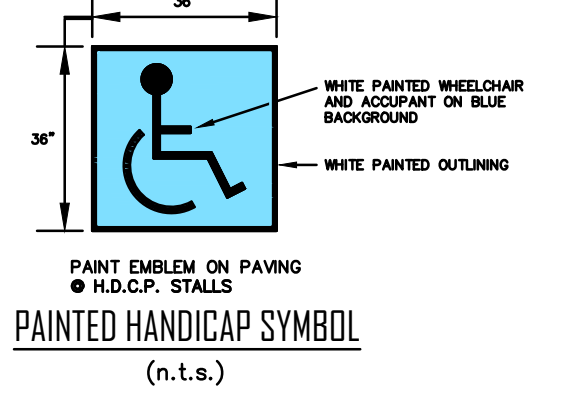
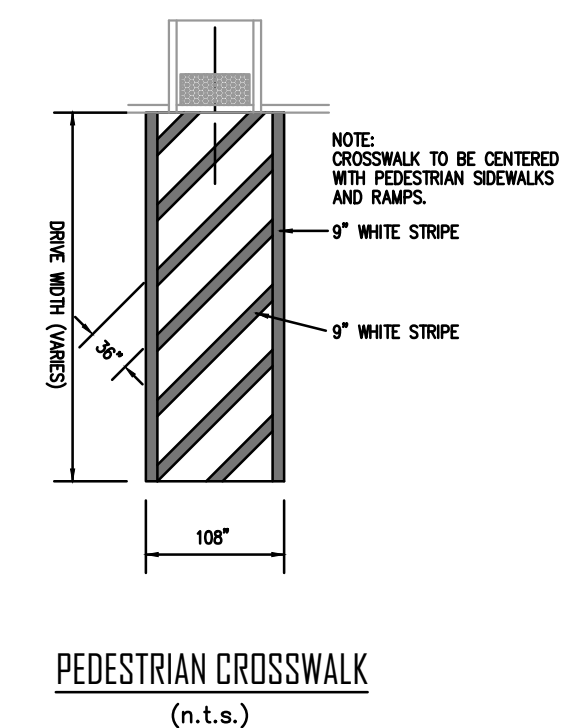
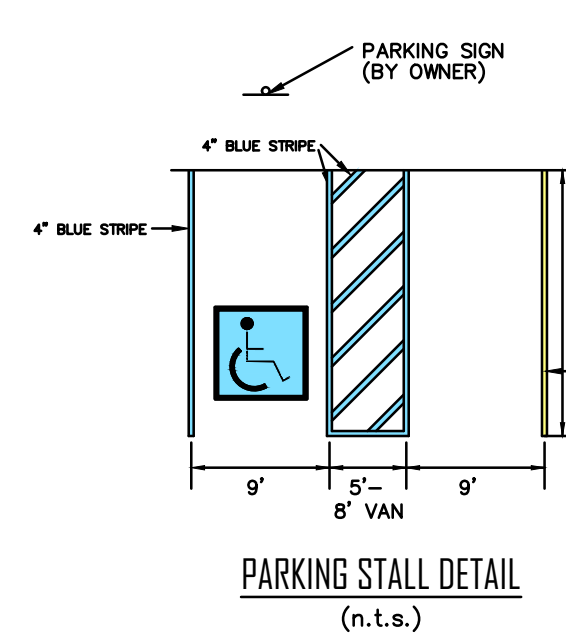

prepared for:
AVMATS JET SUPPORT
18377 EDISON AVENUE
CHESTERFIELD, MISSOURI 63005
ATTN: LAWRENCE HAWKINS

CONTEGRA CONSTRUCTION LLC
3050 WEST CLAY STREET
ST. CHARLES, MISSOURI 63301
ATTN: JASON PREWITT

A TRACT OF LAND BEING LOT 19 OF SPIRIT OF ST. LOUIS AIRPORT PLAT 1
AS RECORDED IN PLAT BOOK 258, PAGE 74
TOWNSHIP 45 NORTH, RANGE 3 EAST OF THE 5TH PRINCIPAL MERIDIAN
CITY OF CHESTERFIELD, ST. LOUIS COUNTY, MISSOURI

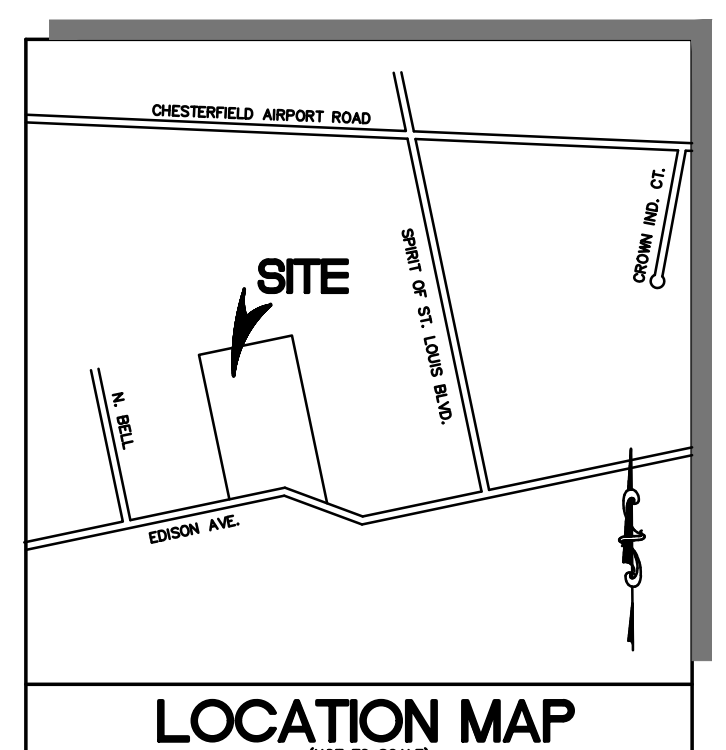

SITE INFORMATION

ADDRESS = 18301 EDISON AVENUE
CHESTERFIELD, MO 63005

LOT = 9.27 ACRES

OWNER = CENTURION INVESTMENTS, INC.

CITY = CITY OF CHESTERFIELD

ZONING = "M3" PLANNED INDUSTRIAL DISTRICT

ORDINANCE NO. = 1430

FLOOD MAP = 29189C0145K

SEWER DISTRICT = MSD

WATERSHED = MISSOURI RIVER

FIRE DISTRICT = MONARCH CHESTERFIELD

SCHOOL DISTRICT = ROCKWOOD R-6

ELECTRIC SERVICE = AMEREN

GAS SERVICE = SPIRE

PHONE SERVICE = AT&T

WATER SERVICE = MISSOURI-AMERICAN WATER CO.

CABLE SERVICE = CHARTER COMMUNICATIONS

SPIRIT OF ST. LOUIS AIRPORT OPERATES UNDER THE FOLLOWING PERMITS:
GENERAL PERMIT MO-RB0F016 AND LAND DISTURBANCE PERMIT MOR 103441

PARKING CALCULATIONS

TOTAL BUILDING AREA DATA: HANGAR: 74,433 S.F. WAREHOUSE: 14,103 S.F. OFFICE: 4,487 S.F. TOTAL: 93,033 S.F.	EXPANSION BUILDING AREA DATA: HANGAR: 39,300 S.F. WAREHOUSE: 8,733 S.F. OFFICE: 0 S.F.	EXISTING BUILDING AREA DATA: HANGAR: 35,133 S.F. WAREHOUSE: 5,370 S.F. OFFICE: 4,487 S.F.
REQUIRED PARKING (MINIMUM): OFFICE: 3.3/1,000 GFA = 3.3/1,000 x 4,487 = 14 SPACES WAREHOUSE/HANGAR: 2 SPACES FOR EVERY 3 EMPLOYEES ON THE MAXIMUM SHIFT (40 EMPLOYEES = 27 SPACES)		
TOTAL PERMITTED (MINIMUM): 41 SPACES		
(MAXIMUM) OFFICE: 4.5/1,000 GFA = 4.5/1,000 x 4,487 = 20 SPACES WAREHOUSE/HANGAR: 1.2 SPACES PER EMPLOYEE ON THE MAXIMUM SHIFT (40 EMPLOYEES = 48 SPACES)		
TOTAL PERMITTED (MAXIMUM): 68 SPACES		
TOTAL PROVIDED: 55 SPACES (2 ACCESSIBLE)		
REQUIRED LOADING: 10x40 LOADING SPACE (3) 10x25 LOADING SPACE (0)		
TOTAL REQUIRED: 3 SPACES (10x40) 3 SPACES (10x40) 1 SPACE (10x25)		
TOTAL PROVIDED: 3 SPACES (10x40) 3 SPACES (10x40) 1 SPACE (10x25)		

OPEN SPACE CALCULATIONS

LOT AREA: 404,176 S.F.	
BUILDING AREA: 93,033 S.F.	
F.A.R.: (93,033 / 404,176) 0.23	
VEHICLE PAVEMENT AREA: 98,462 S.F.	
PERCENT OPENSPACE: [(404,176 - (93,033+98,462)) / 404,176] x 100 = 52.62%	

AVMATS Jet Support, the owner of the property shown on this plan for and in consideration of being granted approval of said plan to develop property under the provisions of Section 03, _____ of City of _____ (applicable subsection) (present Zoning) _____, do hereby agree and declare that said property from the date of recording this plan shall be developed only as shown thereon, unless said plan is amended by the City of Chesterfield, or voided or vacated by order of ordinance of the City of Chesterfield Council.

Signature: _____

Name: _____

State of _____)
) SS.
County of _____)

On this _____ day of _____, A.D., 2024, before me personally appeared _____, to me known, who, being by me sworn in, did say (Officer of Corporation) _____ of _____ a corporation in the State of _____, and that the seal affixed to the foregoing instruments is the corporate seal of said corporation, and that said instrument was signed on behalf of said corporation by authority of its Board of Directors, and the said _____ acknowledged said _____ (Officer of Corporation) instrument to be the free act and deed of said corporation.

In testimony whereof, I have hereunto set my hand and affixed my Notarial Seal at my office in _____, the day and year last above written.
(County and State)

My term expires _____

Notary Public

This Site Development Plan was approved by the City of Chesterfield and duly verified on the _____ day of _____, 2024, by the Chairperson of said Commission, authorizing the recording of this Site Development Plan pursuant to Chesterfield Ordinance Number 200, as attested to by the Director of Planning and the City Clerk.

Justin Wyse, AICP
Director of Planning
City of Chesterfield, Missouri

Vickie McGowdn, City Clerk
City of Chesterfield, Missouri

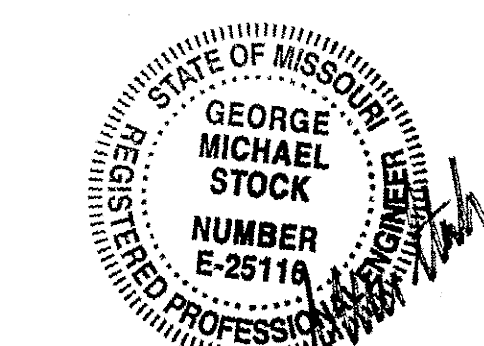

George M. Stock, P.E. E-25116
Civil Engineer, Cert. Authority No. 000996



ACI/Boland, Inc.
Kansas City | St. Louis
17107 Chesterfield Airport Road, Suite 110
Chesterfield, MO 63005
T: 314.991.9993

Licensee's Certificate of Authority Number:
Missouri: #000958

CIVIL

Stock & Associates
257 Chesterfield Business Parkway
St. Louis, MO 63005
(636) 519-8668
Licensee's Certificate of Authority Number:

LANDSCAPE

Loomis Associates
750 Spirit 40 Park Dr.
Chesterfield, MO 63005
(636) 519-8668
Licensee's Certificate of Authority Number:

GENERAL CONTRACTOR

Contegra
3050 W. Clay St., Suite 300
St. Charles, MO 63301
(618) 219-4868
Licensee's Certificate of Authority Number:

AVMATS HANGAR 45
18301 EDISON AVENUE
CHESTERFIELD, MO 63005

GEOTECHNICAL ENGINEER'S STATEMENT

SCI ENGINEERING, INC., at the request of Contegra Construction Company has provided geotechnical services for the project proposed hereon. A geotechnical investigation titled "Geotechnical Report AVMATS HANGAR CHESTERFIELD, MISSOURI", May 2018, SCI No. 2009-0313.11. Our findings indicate that the earth-related aspects are suitable for the development proposed pursuant to the geotechnical recommendations set forth in our Geotechnical Report.

Timothy J. Barrett, P.E.
12/4/23
Date



SURVEYOR CERTIFICATE

This is to certify that Stock & Associates Consulting Engineers, Inc. has prepared this Site Development Section Plan from an actual survey. The information shown is a correct representation of all existing and proposed land divisions.

STOCK AND ASSOCIATES CONSULTING ENGINEERS, INC.
LC 222-D

Walter J. Pfeiffer
Walter J. Pfeiffer, Missouri P.L.S. No. 2008-000728



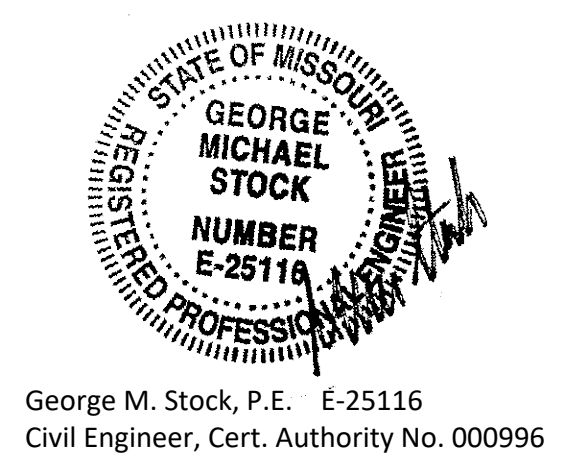
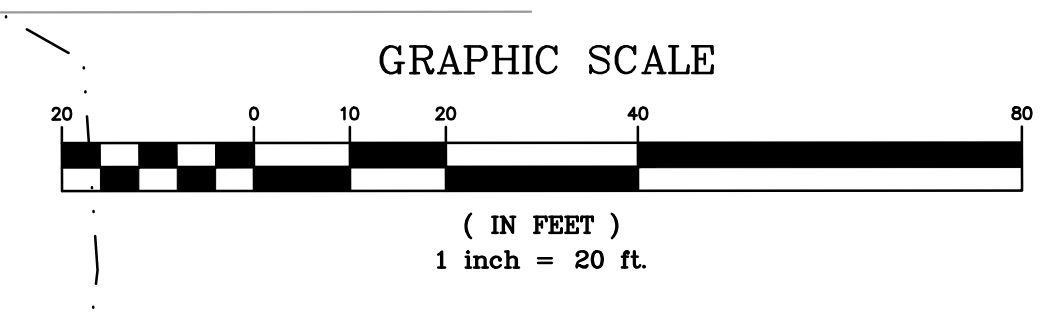
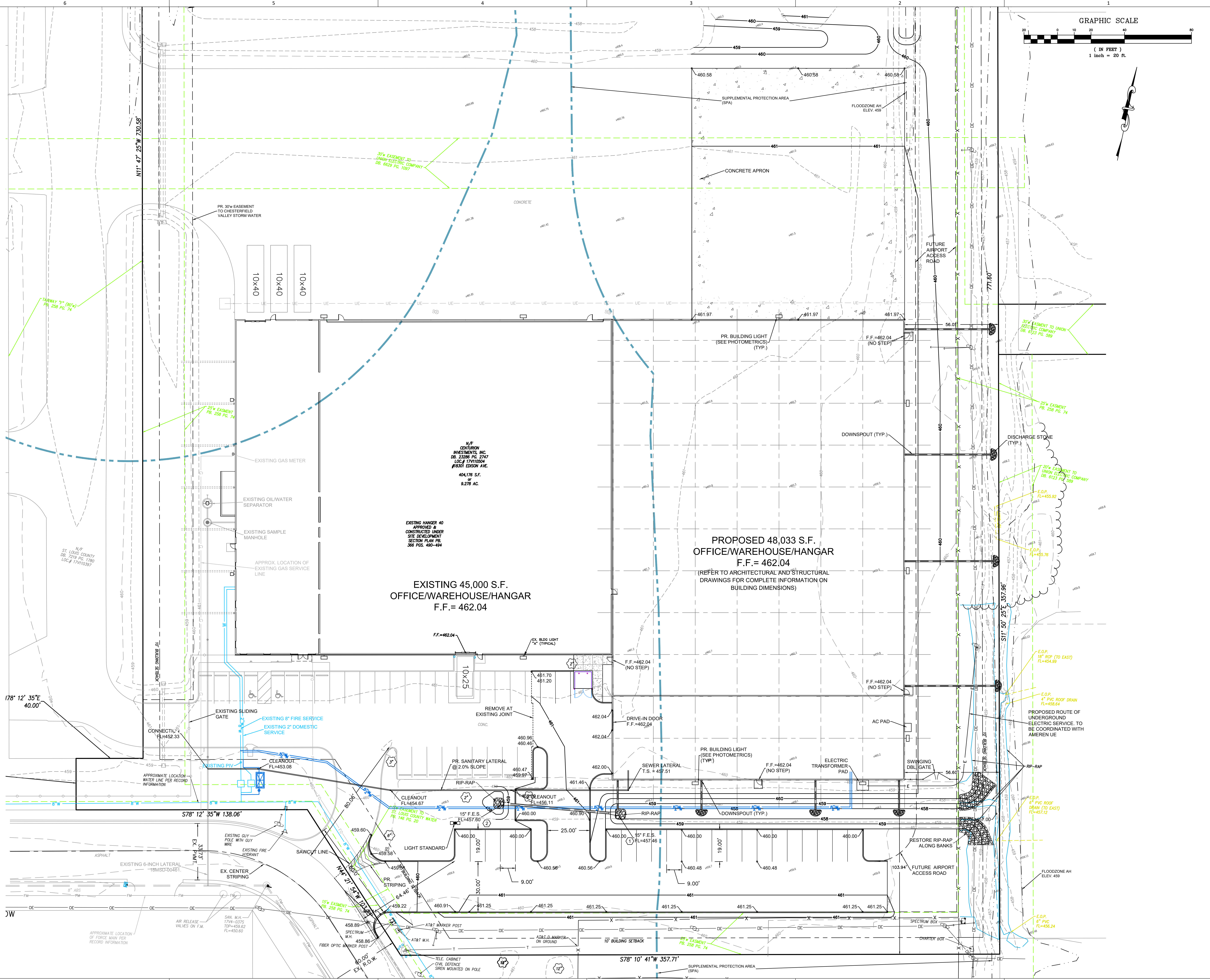

George M. Stock, P.E. E-25116
Civil Engineer, Cert. Authority No. 000996

ACI BOLAND ARCHITECTS

ACI/Boland, Inc.
Kansas City | St. Louis
17107 Chesterfield Airport Road, Suite 110
Chesterfield, MO 63005
T: 314.991.9993
Licensee's Certificate of Authority Number:
Missouri: #000958

CIVIL
Stock & Associates
257 Chesterfield Business Parkway
St. Louis, MO 63005
(636) 530-9100
Licensee's Certificate of Authority Number:

LANDSCAPE
Loomis Associates
750 Spirit 40 Park Dr.
Chesterfield, MO 63005
(636) 519-8668
Licensee's Certificate of Authority Number:

GENERAL CONTRACTOR
Contegra
3050 W. Clay St., Suite 300
St. Charles, MO 63301
(618) 219-4868
Licensee's Certificate of Authority Number:

AVMATS HANGAR 45 18301 EDISON AVENUE CHESTERFIELD, MO 63005

Date 12/04/2023
Job Number 218-6256.3
Drawn By JEF
Checked By GMS

Number	Date	Description
1	11/26/24	City Comments
2	2/28/24	City Comment



Jerald Saunders - Landscape Architect
License - Missouri License # LA-007

ACI BOLAND ARCHITECTS

ACI/Boland, Inc.
Kansas City | St. Louis
17107 Chesterfield Airport Road, Suite 110
Chesterfield, MO 63005
T: 314.991.9993
Licensee's Certificate of Authority Number
Missouri: #000958

CIVIL
Stock & Associates
257 Chesterfield Business Parkway
St. Louis, MO 63005
(636) 530-9100
Licensee's Certificate of Authority Number:

LANDSCAPE
Loomis Associates
750 Spirit 40 Park Dr.
Chesterfield, MO 63005
(636) 519-8668
Licensee's Certificate of Authority Number:

GENERAL CONTRACTOR
Contegra
3050 W. Clay St., Suite 300
St. Charles, MO 63301
(618) 219-4868
Licensee's Certificate of Authority Number:

AVMATS HANGAR 45
18301 EDISON AVENUE
CHESTERFIELD, MO 63005

Date 1/23/24
Job Number 2-23064
Drawn By KP
Checked By RS



L1.01

© 2023 ACI/BOLAND, Inc. LANDSCAPE PLAN

Landscape Notes:

- 1) Lawn areas shall be turf-type Tall Fescue Grass or approved equivalent.
 - 2) All 3:1 or steeper slopes shall be lawn seed and have erosion control blanket.
 - 3) Topsoil in all disturbed lawn areas at 6" depth.
 - 4) Protect and maintain all irrigation systems. Adapt existing system to accommodate new landscape area around building.
- Zone lawns independent of shrub beds.

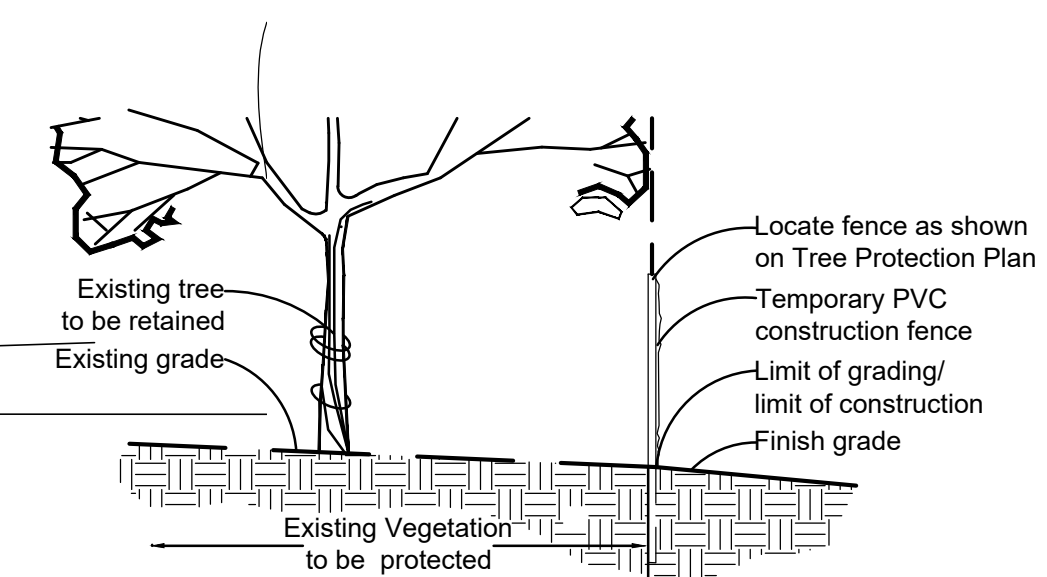
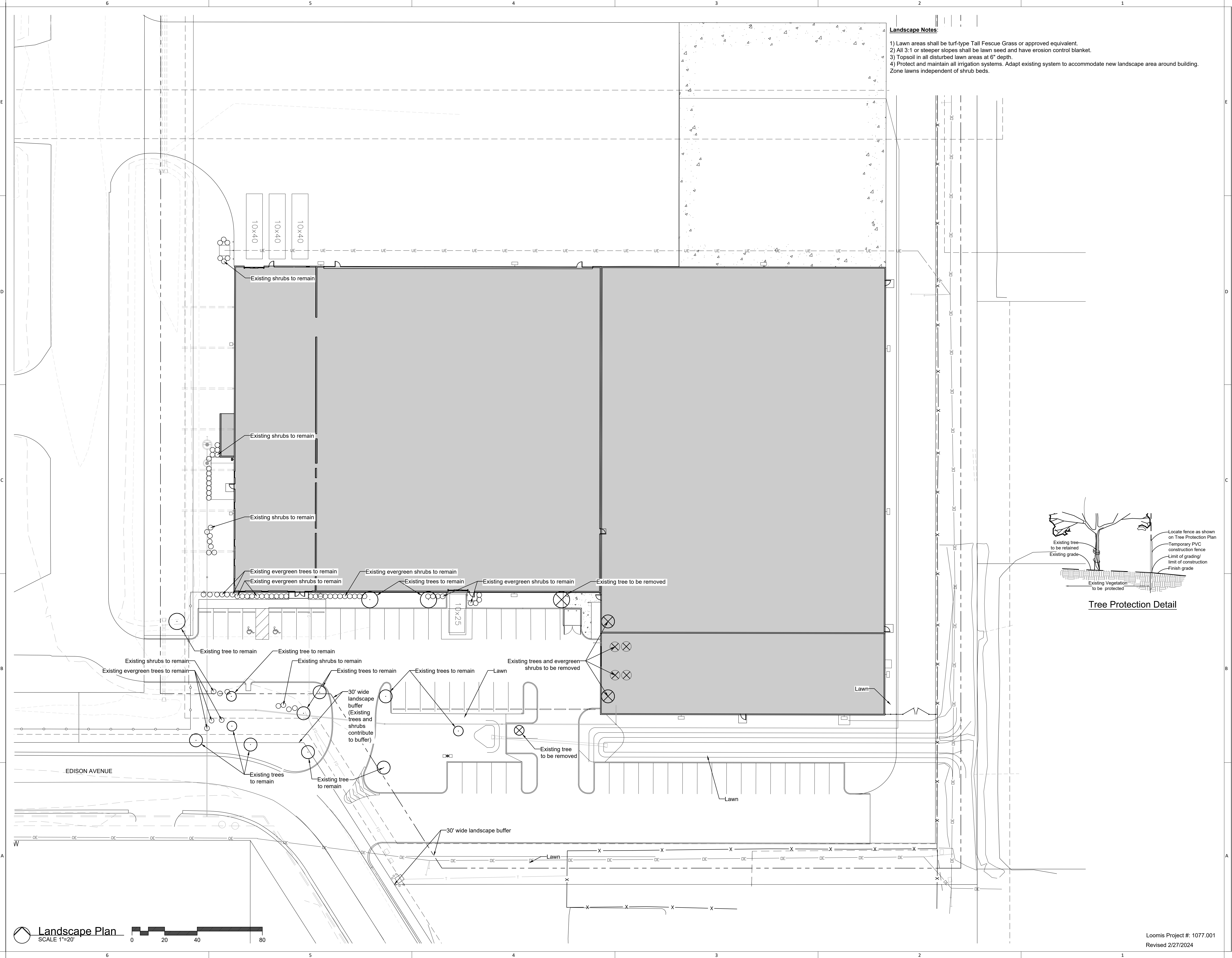

Tree Protection Detail

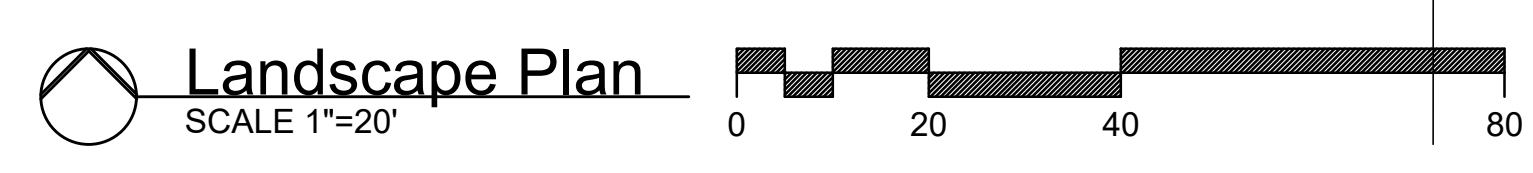

Loomis Project #: 1077.001
Revised 2/27/2024

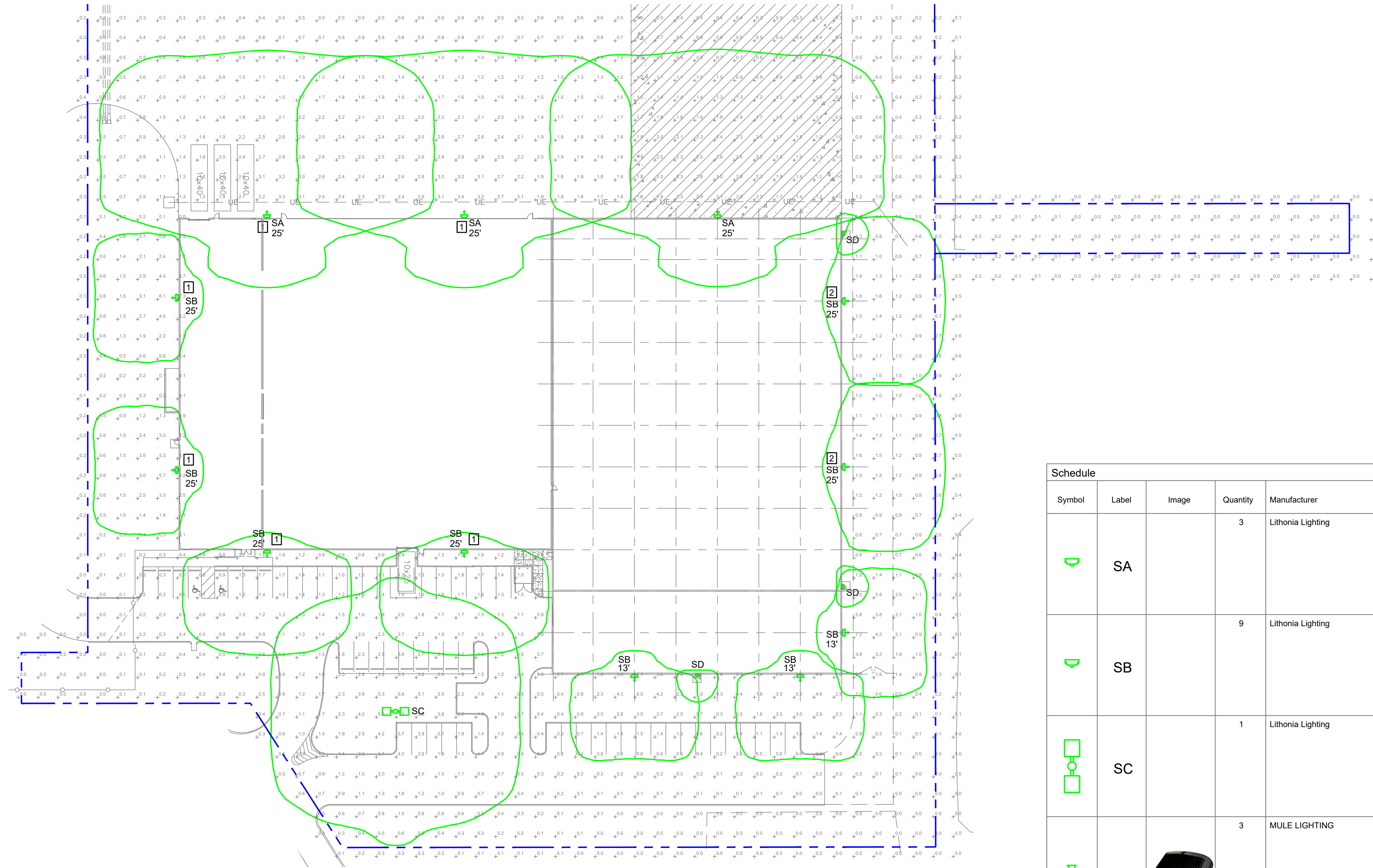

Site Photometric Plan
SCALE: 1" = 40'-0"

THE PHOTOMETRIC INFORMATION SHOWN ON THIS DRAWING ARE A PRODUCT OF A NUMERIC PROGRAM THEY ARE MEANT AS A REPRESENTATION OF ANTICIPATED LIGHT LEVELS BASED ON ASSUMED PARAMETERS AND CONDITIONS. THE ACTUAL RESULTS WILL VARY AND NO GUARANTIES ARE INTENDED OR IMPLIED IN THIS REPRESENTATION

Schedule

Symbol	Label	Image	Quantity	Manufacturer	Catalog Number	Description	Number Lamps	Lumens Per Lamp	Light Loss Factor	Wattage	Plot
SA	SA		3	Lithonia Lighting	DSX2 LED P7 40K 80CRI T4M	D-Series Size 2 Area Luminaire P7 Performance Package 4000K CCT 80 CRI Type 4 Medium	1	47921	0.9	409.13	
SB	SB		9	Lithonia Lighting	DSX1 LED P4 40K 80CRI TFTM HS	D-Series Size 1 Area Luminaire P4 Performance Package 4000K CCT 80 CRI Forward Throw Houseside Shield	1	12607	0.9	123.9373	
SC	SC		1	Lithonia Lighting	RSX2 LED P3 40K R4	RSX Area Fixture Size 2 P3 Lumen Package 4000K CCT Type R4 Distribution	1	22020	0.9	299.96	
SD	SD		3	MULE LIGHTING	MERU-LED-ACEM-DB	LOW PROFILE OUTDOOR LED WITH 4000K LEDS AND POLYCARBONATE COVER/DIFFUSER	1	1600	0.9	32.00	

Statistics

Description	Symbol	Avg	Max	Min	Max/Min	Avg/Min
Calc Zone #2	+	1.0 fc	7.3 fc	0.0 fc	N/A	N/A

KEYED LIGHTING NOTES

- 1 ALL FIXTURES NOTED ARE CONSIDERED EXISTING FIXTURES AND SHALL BE LEFT UNTOUCHED
- 2 ALL FIXTURES NOTED ARE TO BE RELOCATED AND INSTALLED AT NEW LOCATION

THE SEALS AND SIGNATURE(S) APPLY ONLY TO THE DOCUMENT TO WHICH THEY ARE AFFIXED FOR ELECTRICAL DESIGN ONLY AND EXPRESSLY DISCLAIM ANY RESPONSIBILITY FOR ALL OTHER PLANS, SPECIFICATIONS, ESTIMATES, REPORTS OR OTHER DOCUMENTS AND INSTRUMENTS RELATING TO OR INTENDED TO BE USED FOR ANY PART OF THE ARCHITECTURAL OR ENGINEERING PROJECT.

Rev.	Description	Date	By
0	Photometric Review Set	11/29/2023	TDL
1	Revised Photometric Review Set	02/06/2024	TDL
2	Revised Photometric Review Set	03/06/2024	JPW

New Building Expansion:
Avmats - Hangar 45
16301 Edison Avenue
Chesterfield, MO 63005

10 Sunnen Drive
Suite 125
St. Louis, MO 63143
Office: 314.781.2400
Fax: 314.781.4720
www.rjpelectric.com

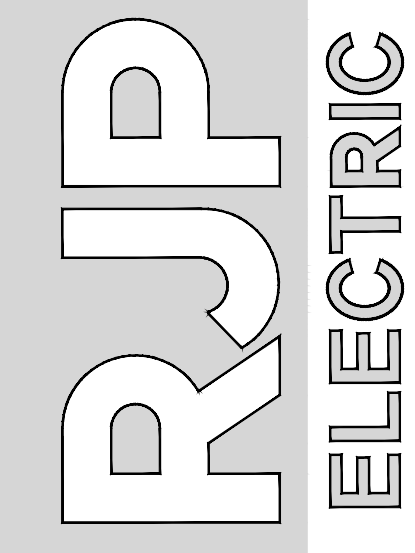

SHEET NO.
LC-1



D-Series Size 2 LED Area Luminaire

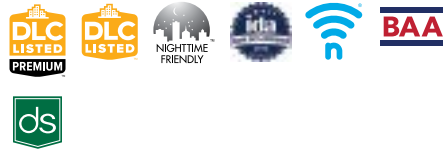

d#series

Specifications

EPA:	1.06 ft ² (0.10 m ²)
Length:	40.59" (103.1 cm)
Width:	16.76" (42.6 cm)
Height H1:	8.11" (20.6 cm)
Height H2:	3.96" (10.1 cm)
Weight:	46 lbs (20.9 kg)

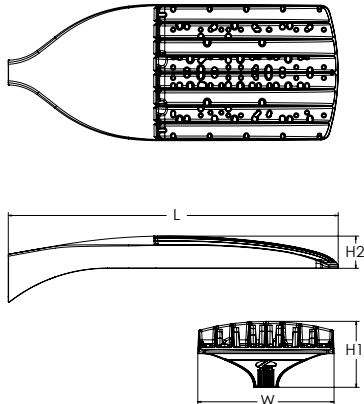

ds Design Select options indicated by this color background.

Catalog
Number

Notes

Type

Hit the Tab key or mouse over the page to see all interactive elements.

Introduction

The modern styling of the D-Series features a highly refined aesthetic that blends seamlessly with its environment. The D-Series offers the benefits of the latest in LED technology into a high performance, high efficacy, long-life luminaire.

The outstanding photometric performance results in sites with excellent uniformity, greater pole spacing and lower power density. D-Series outstanding photometry aids in reducing the number of poles required in area lighting applications with typical energy savings of up to 80% vs. 1000W HID and expected service life of over 100,000 hours.



Items marked by a shaded background qualify for the Design Select program and ship in 15 days or less. To learn more about Design Select, visit www.acuitybrands.com/designselect. *See ordering tree for details

Ordering Information

EXAMPLE: DSX2 LED P7 40K 70CRI T3M MVOLT SPA NLTAIR2 PIRHN DDBXD

DSX2 LED	Series	LEDs	Color temperature ²	Color Rendering Index ²	Distribution	Voltage	Mounting		
DSX2 LED	Forward optics	P1 P5 P2 P6 P3 P7 P4 P8	(this section 70CRI only)		AFR Automotive front row T1S Type I short T2M Type II medium T3M Type III medium T3LG Type III low glare ³ T4M Type IV medium T4LG Type IV low glare ³ TFTM Forward throw medium	TSM Type V medium TSLG Type V low glare TSW Type V wide BLC3 Type III backlight control ³ BLC4 Type IV backlight control ³ LCCO Left corner cutoff ³ RCCO Right corner cutoff ³	MVOLT (120V-277V) ⁴ HVOLT (347V-480V) ^{5,6} XVOLT (277V - 480V) ^{7,8} 120 ^{16,26} 208 ^{16,26} 240 ^{16,26} 277 ^{16,26} 347 ^{16,26} 480 ^{16,26}	Shipped included SPA Square pole mounting (#8 drilling) RPA Round pole mounting (#8 drilling) SPA5 Square pole mounting #5 drilling ⁹ RPA5 Round pole mounting #5 drilling ⁹ SPA8N Square narrow pole mounting #8 drilling WBA Wall bracket ¹⁰ MA Mast arm adapter (mounts on 2 3/8" OD horizontal tenon)	
			(this section 80CRI only, extended lead times apply)						
			P10 ¹ P13 ¹ P11 ¹ P14 ¹ P12 ¹	27K 2700K					80CRI
				30K 3000K					80CRI
				35K 3500K	80CRI				
				40K 4000K	80CRI				
				50K 5000K	80CRI				

Control options	Other options	Finish (required)
<p>Shipped installed</p> <p>NLTAIR2 PIRHN nLight AIR gen 2 enabled with bi-level motion / ambient sensor, 8-40' mounting height, ambient sensor enabled at 2fc.^{11,12,20,21}</p> <p>PIR High/low, motion/ambient sensor, 8-40' mounting height, ambient sensor enabled at 2fc.^{13,20,21}</p> <p>PER NEMA twist-lock receptacle only (controls ordered separate)¹⁴</p> <p>PER5 Five-pin receptacle only (controls ordered separate)^{14,21}</p> <p>PER7 Seven-pin receptacle only (controls ordered separate)^{14,21}</p> <p>FA0 Field adjustable output^{15,21}</p> <p>BL30 Bi-level switched dimming, 30%^{16,21}</p> <p>BL50 Bi-level switched dimming, 50%^{16,21}</p> <p>DMG 0-10v dimming wires pulled outside fixture (for use with an external control, ordered separately)¹⁷</p> <p>DS Dual switching^{18,19,21}</p>	<p>Shipped installed</p> <p>SPD20KV 20KV surge protection</p> <p>HS Houseside shield (black finish standard)²²</p> <p>L90 Left rotated optics¹</p> <p>R90 Right rotated optics¹</p> <p>CCE Coastal Construction²³</p> <p>HA 50°C ambient operation²⁴</p> <p>BAA Buy America(n) Act Compliant</p> <p>SF Single fuse (120, 277, 347V)²⁵</p> <p>DF Double fuse (208, 240, 480V)²⁶</p> <p>3G Vibration rated for 3G²⁷</p>	<p>Shipped separately</p> <p>EGSR External Glare Shield (reversible, field install required, matches housing finish)</p> <p>BSDB Bird Spikes (field install required)</p> <p>DDBXD Dark Bronze</p> <p>DBLXD Black</p> <p>DNAXD Natural Aluminum</p> <p>DWHXD White</p> <p>DDBTXD Textured dark bronze</p> <p>DBLTXD Textured black</p> <p>DNATXD Textured natural aluminum</p> <p>DWHGXD Textured white</p>



One Lithonia Way • Conyers, Georgia 30012 • Phone: 1-800-705-SERV (7378) • www.lithonia.com
© 2011-2023 Acuity Brands Lighting, Inc. All rights reserved.

DSX2-LED
Rev. 10/30/23
Page 1 of 10

Ordering Information

Accessories

Ordered and shipped separately.

DLL127F 1.5 JU	Photocell - SSL twist-lock (120-277V) ²⁵
DLL347F 1.5 CUL JU	Photocell - SSL twist-lock (347V) ²⁵
DLL480F 1.5 CUL JU	Photocell - SSL twist-lock (480V) ²⁵
DSHORT SBK	Shorting cap ²⁵
DSX2HS P#	House-side shield (enter package number 1-13 in place of #)
DSXRPA (FINISH)	Round pole adapter (#8 drilling, specify finish)
DSXSPA5 (FINISH)	Square pole adapter #5 drilling (specify finish)
DSXRPA5 (FINISH)	Round pole adapter #5 drilling (specify finish)
DSX1EGSR (FINISH)	External glare shield (specify finish)
DSX2B5DB (FINISH)	Bird spike deterrent bracket (specify finish)

NOTES

- Rotated optics available with packages P10, P11, P12, P13 and P14. Must be combined with option L90 or R90.
- 30K, 40K, and 50K available in 70CRI and 80CRI. 27K and 35K only available with 80CRI. Contact Technical Support for other possible combinations.
- T3LG, T4LG, BLC3, BLC4, LCCO, RCCO not available with option HS.
- MVOLT driver operates on any line voltage from 120-277V (50/60 Hz).
- HVOLT driver operates on any line voltage from 347-480V (50/60 Hz).
- HVOLT not available with package P10 when combined with option NLTAIR2 PIRHN or option PIR.
- XVOLT operates with any voltage between 277V and 480V (50/60 Hz).
- XVOLT not available in package P10. XVOLT not available with fusing (SF or DF).
- SPA5 and RPA5 for use with #5 drilling only (Not for use with #8 drilling).
- WBA cannot be combined with Type 5 distributions plus photocell (PER).
- NLTAIR2 and PIRHN must be ordered together. For more information on nLight AIR2 visit this [link](#).
- NLTAIR2 PIRHN not available with other controls including PIR, PER, PER5, PER7, FAO, BL30, BL50, DMG and DS. NLTAIR2 PIRHN not available with P10 using HVOLT. NLTAIR2 PIRHN not available with P10 using XVOLT.
- PIR not available with NLTAIR2 PIRHN, PER, PER5, PER7, FAO BL30, BL50, DMG and DS. PIR not available with P10 using HVOLT. PIR not available with P10 using XVOLT.
- 14) PER/PER5/PER7 not available with NLTAIR2 PIRHN, PIR, BL30, BL50, FAO, DMG and DS. Photocell ordered and shipped as a separate line item from Acuity Brands Controls. See accessories. Shorting Cap included.
- FAO not available with other dimming control options NLTAIR2 PIRHN, PIR, PER5, PER7, BL30, BL50, DMG and DS.
- BL30 and BL50 are not available with NLTAIR2 PIRHN, PIR, PER, PER5, PER7, FAO, DMG and DS. BL30 or BL50 must specify 120, 277 or 347V. Consult tech support for 208, 240 or 480V.
- DMG not available with NLTAIR2 PIRHN, PIR, PER, PER5, PER7, BL30, BL50, FAO and DS.
- DS not available with NLTAIR2 PIRHN, PIR, PER, PER5, PER7, BL30, BL50, FAO and DMG.
- DS requires (2) separately switched circuits. DS provides 50/50 fixture operation via (2) different sets of leads on P1, P2, P3, P4, P5 (2 drivers). Note: Provides 60/40 operation using (2) different sets of leads on P6, P7, P8, P9, P10, P11, P12, P13, P14 (3 drivers).
- Reference Motion Sensor Default Settings table on page 4 to see functionality.
- Reference Controls Options table on page 4.
- HS not available with T3LG, T4LG, BLC3, BLC4, LCCO and RCCO distribution. Also available as a separate accessory; see Accessories information.
- CCE option not available with option BS and EGSR. Contact Technical Support for availability.
- Option HA not available with performance packages P5, P6, P7, P8, P13 and P14.
- Requires luminaire to be specified with PER, PER5 or PER7 option. See Controls Table on page 4.
- Single fuse (SF) requires 120V, 277V, or 347V. Double fuse (DF) requires 208V, 240V or 480V. XVOLT not available with fusing (SF or DF).
- Option 3G for use with (MA) mast arm mount only when 3G vibration is required.

Shield Accessories



External Glare Shield (EGSR)

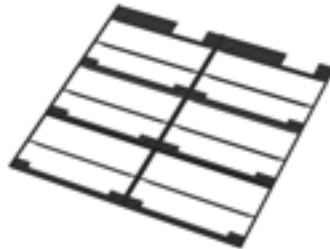

House Side Shield (HS)

Drilling

HANDHOLE ORIENTATION

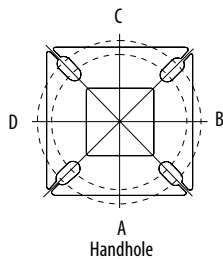

Template #8

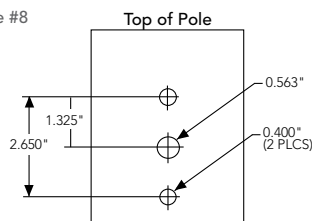

Tenon Mounting Slipfitter

Tenon O.D.	Mounting	Single Unit	2 @ 180	2 @ 90	3 @ 90	3 @ 120	4 @ 90
2-3/8"	RPA	AS3-5 190	AS3-5 280	AS3-5 290	AS3-5 390	AS3-5 320	AS3-5 490
2-7/8"	RPA	AST25-190	AST25-280	AST25-290	AST25-390	AST25-320	AST25-490
4"	RPA	AST35-190	AST35-280	AST35-290	AST35-390	AST35-320	AST35-490

Mounting Option	Drilling Template	Single	2 @ 180	2 @ 90	3 @ 90	3 @ 120	4 @ 90
Head Location		Side B	Side B & D	Side B & C	Side B, C & D	Round Pole Only	Side A, B, C & D
Drill Nomenclature	#8	DM19AS	DM28AS	DM29AS	DM39AS	DM32AS	DM49AS
Minimum Acceptable Outside Pole Dimension							
SPA	#8	3.5"	3.5"	3.5"	3.5"		3.5"
RPA	#8	3"	3"	3"	3"	3"	3"
SPA5	#5	3"	3"	3"	3"		3"
RPA5	#5	3"	3"	3"	3"	3"	3"
SPA8N	#8	3"	3"	3"	3"		3"

DSX2 Area Luminaire - EPA

*Includes luminaire and integral mounting arm. Other tenons, arms, brackets or other accessories are not included in this EPA data.

Fixture Quantity & Mounting Configuration	Single DM19	2 @ 180 DM28	2 @ 90 DM29	3 @ 90 DM39	3 @ 120 DM32	4 @ 90 DM49
Mounting Type						
DSX2 with SPA	1.06	2.12	1.84	2.32	---	2.33
DSX2 with SPA5, SPA8N	1.07	2.14	1.90	2.43	---	2.44
DSX2 with RPA, RPA5	1.07	2.14	1.90	2.43	2.31	2.44
DSX2 with MA	1.20	2.40	2.12	3.00	2.92	3.00

Photometric Diagrams

To see complete photometric reports or download .ies files for this product, visit Lithonia Lighting's [homepage](#).

Isofootcandle plots for the DSX2 LED P8 40K 70CRI. Distances are in units of mounting height (40').

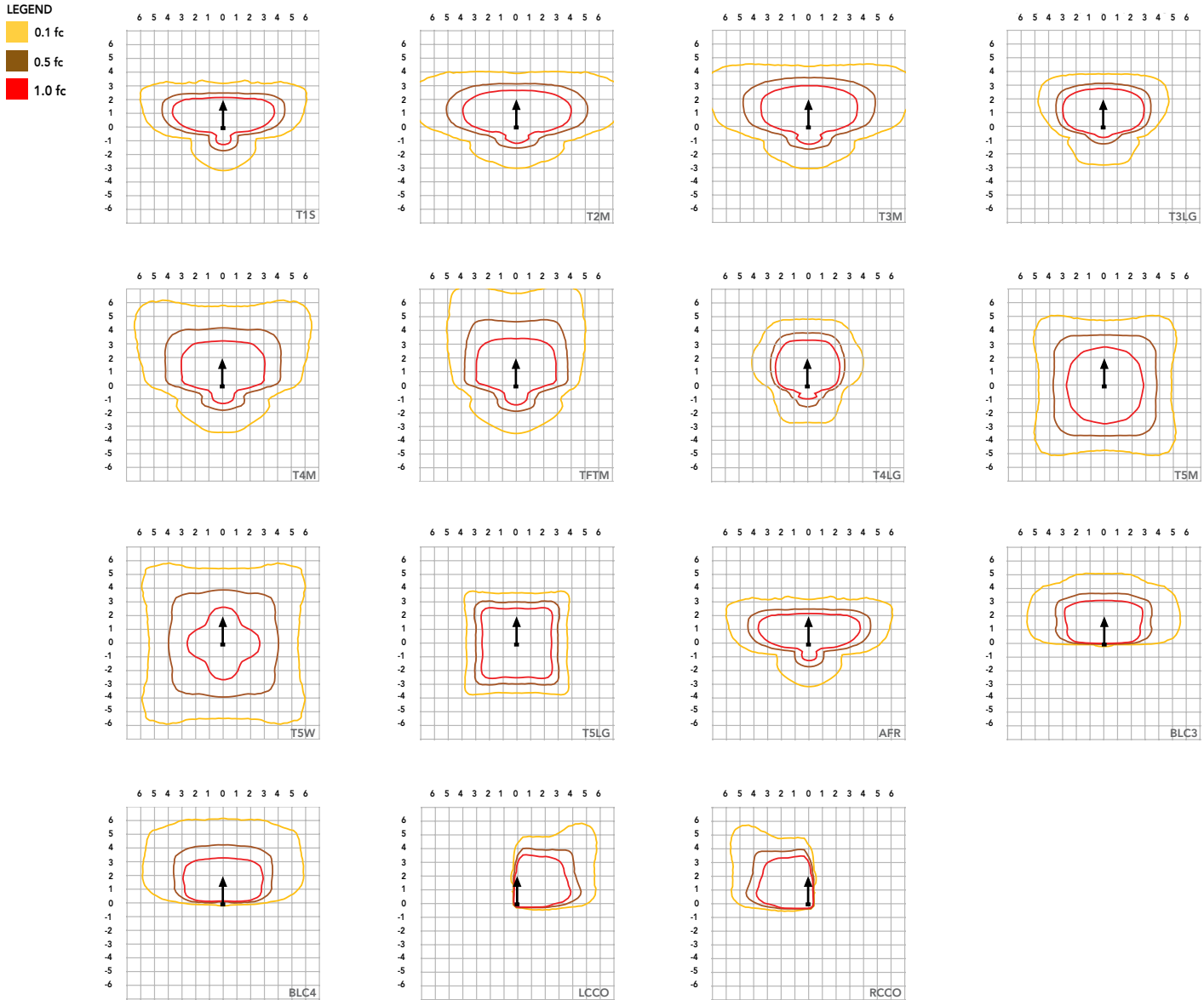

Performance Data

Lumen Ambient Temperature (LAT) Multipliers

Use these factors to determine relative lumen output for average ambient temperatures from 0-40°C (32-104°F).

Ambient		Lumen Multiplier
0°C	32°F	1.04
5°C	41°F	1.03
10°C	50°F	1.03
15°C	59°F	1.02
20°C	68°F	1.01
25°C	77°F	1.00
30°C	86°F	0.99
35°C	95°F	0.98
40°C	104°F	0.97

Projected LED Lumen Maintenance

Data references the extrapolated performance projections for the platforms noted in a **25°C ambient**, based on 10,000 hours of LED testing (tested per IESNA LM-80-08 and projected per IESNA TM-21-11).

To calculate LLF, use the lumen maintenance factor that corresponds to the desired number of operating hours below. For other lumen maintenance values, contact factory.

Operating Hours	Lumen Maintenance Factor
0	1.00
25,000	0.95
50,000	0.90
100,000	0.82

FAO Dimming Settings

FAO Position	% Wattage	% Lumen Output
8	100%	100%
7	93%	95%
6	80%	85%
5	66%	73%
4	54%	61%
3	41%	49%
2	29%	36%
1	15%	20%

*Note: Calculated values are based on original performance package data. When calculating new values for given FAO position, use published values for each package based on input watts and lumens by optic type.

Electrical Load

	Performance Package	LED Count	Drive Current (mA)	Wattage	Current (A)					
					120V	208V	240V	277V	347V	480V
Forward Optics (Non-Rotated)	P1	80	530	135	1.12	0.65	0.56	0.49	0.39	0.28
	P2	80	700	181	1.49	0.86	0.75	0.65	0.52	0.37
	P3	80	850	222	1.83	1.05	0.91	0.79	0.63	0.46
	P4	80	1050	277	2.27	1.31	1.14	0.98	0.79	0.57
	P5	80	1250	333	2.72	1.57	1.36	1.18	0.94	0.68
	P6	100	1050	345	2.85	1.64	1.42	1.23	0.98	0.71
	P7	100	1250	414	3.41	1.97	1.70	1.48	1.18	0.85
	P8	100	1400	466	3.85	2.22	1.93	1.67	1.33	0.96
Rotated Optics (Requires L90 or R90)	P10	90	530	152	1.27	0.73	0.63	0.55	0.44	0.32
	P11	90	700	203	1.69	0.97	0.84	0.73	0.58	0.42
	P12	90	850	249	2.06	1.19	1.03	0.89	0.71	0.52
	P13	90	1200	358	2.95	1.70	1.47	1.28	1.02	0.74
	P14	90	1400	421	3.46	2.00	1.73	1.50	1.20	0.87

LED Color Temperature / Color Rendering Multipliers

	70 CRI		80CRI		90CRI	
	Lumen Multiplier	Availability	Lumen Multiplier	Availability	Lumen Multiplier	Availability
5000K	102%	Standard	92%	Extended lead-time	71%	(see note)
4000K	100%	Standard	92%	Extended lead-time	67%	(see note)
3500K	100%	(see note)	90%	Extended lead-time	63%	(see note)
3000K	96%	Standard	87%	Extended lead-time	61%	(see note)
2700K	94%	(see note)	85%	Extended lead-time	57%	(see note)

Note: Some LED types are available as per special request. Contact Technical Support for more information.

Motion Sensor Default Settings

Option	Unoccupied Dimmed Level	High Level (when occupied)	Photocell Operation	Dwell Time	Ramp-up Time	Dimming Fade Rate
PIR	30%	100%	Enabled @ 2FC	7.5 min	3 sec	5 min
PIRHN	30%	100%	Enabled @ 2FC	7.5 min	3 sec	5 min

Controls Options

Nomenclature	Description	Functionality	Primary control device	Notes
FAO	Field adjustable output device installed inside the luminaire; wired to the driver dimming leads.	Allows the luminaire to be manually dimmed, effectively trimming the light output.	FAO device	Cannot be used with other controls options that need the 0-10V leads
DS (not available on DSX0)	Drivers wired independently for 50/50 luminaire operation	The luminaire is wired to two separate circuits, allowing for 50/50 operation.	Independently wired drivers	Requires two separately switched circuits. Consider nLight AIR as a more cost effective alternative.
PERS or PER7	Twist-lock photocell receptacle	Compatible with standard twist-lock photocells for dusk to dawn operation, or advanced control nodes that provide 0-10V dimming signals.	Twist-lock photocells such as DLL Elite or advanced control nodes such as ROAM.	Pins 4 & 5 to dimming leads on driver, Pins 6 & 7 are capped inside luminaire. Cannot be used with other controls options that need the 0-10V leads.
PIR	Motion sensor with integral photocell. Sensor suitable for 8' to 40' mounting height.	Luminaires dim when no occupancy is detected.	Acuity Controls rSBG	Cannot be used with other controls options that need the 0-10V leads.
NLTAIR2 PIRHN	nLight AIR enabled luminaire for motion sensing, photocell and wireless communication.	Motion and ambient light sensing with group response. Scheduled dimming with motion sensor over-ride when wirelessly connected to the nLight Eclipse.	nLight Air rSBG	nLight AIR sensors can be programmed and commissioned from the ground using the CIAIRity Pro app. Cannot be used with other controls options that need the 0-10V leads.
BL30 or BL50	Integrated bi-level device that allows a second control circuit to switch all light engines to either 30% or 50% light output	BLC device provides input to 0-10V dimming leads on all drivers providing either 100% or dimmed (30% or 50%) control by a secondary circuit	BLC UVOLT1	BLC device is powered off the 0-10V dimming leads, thus can be used with any input voltage from 120 to 480V

Performance Data

Lumen Output

Lumen values are from photometric tests performed in accordance with IESNA LM-79-08. Data is considered to be representative of configurations shown within the tolerances described within LM-79. Contact factory for performance data on any configurations not shown here.

Forward Optics																							
Performance Package	System Watts	LED Count	Drive Current (mA)	Distribution Type	30K					40K					50K								
					(3000K, 70 CRI)					(4000K, 70 CRI)					(5000K, 70 CRI)								
					Lumens	B	U	G	LPW	Lumens	B	U	G	LPW	Lumens	B	U	G	LPW				
P1	135W	80	530	T1S	19,946	2	0	3	148	20,787	2	0	3	155	21,192	2	0	3	158				
				T2M	18,477	3	0	4	137	19,256	3	0	4	143	19,632	3	0	4	146				
				T3M	18,691	3	0	5	139	19,480	3	0	5	145	19,859	3	0	5	148				
				T3LG	16,696	2	0	2	124	17,400	2	0	2	129	17,740	2	0	2	132				
				T4M	18,970	3	0	5	141	19,770	3	0	5	147	20,155	3	0	5	150				
				T4LG	17,253	2	0	2	128	17,981	2	0	2	134	18,331	2	0	2	136				
				TFTM	19,101	3	0	5	142	19,907	3	0	5	148	20,295	3	0	5	151				
				T5M	19,517	5	0	3	145	20,341	5	0	3	151	20,737	5	0	3	154				
				T5W	19,834	5	0	3	147	20,670	5	0	3	154	21,073	5	0	3	157				
				T5LG	19,574	4	0	2	146	20,400	4	0	2	152	20,797	4	0	2	155				
				BLC3	13,595	0	0	3	101	14,169	0	0	3	105	14,445	0	0	3	107				
				BLC4	14,042	0	0	4	104	14,634	0	0	4	109	14,919	0	0	4	111				
				RCCO	13,718	1	0	3	102	14,297	1	0	3	106	14,576	1	0	3	108				
				LCCO	13,718	1	0	3	102	14,297	1	0	3	106	14,576	1	0	3	108				
				AFR	19,946	2	0	3	148	20,787	2	0	3	155	21,192	2	0	3	158				
				P2	179W	80	700	T1S	25,520	3	0	3	142	26,597	3	0	3	148	27,116	3	0	3	151
								T2M	23,641	3	0	5	132	24,638	3	0	5	137	25,118	3	0	5	140
T3M	23,915	3	0					5	133	24,924	3	0	5	139	25,410	3	0	5	142				
T3LG	21,363	3	0					3	119	22,264	3	0	3	124	22,698	3	0	3	127				
T4M	24,272	3	0					5	135	25,296	3	0	5	141	25,789	3	0	5	144				
T4LG	22,075	3	0					3	123	23,006	3	0	3	128	23,455	3	0	3	131				
TFTM	24,440	3	0					5	136	25,471	3	0	5	142	25,967	3	0	5	145				
T5M	24,972	5	0					3	139	26,026	5	0	3	145	26,533	5	0	4	148				
T5W	25,377	5	0					4	142	26,448	5	0	4	148	26,963	5	0	4	150				
T5LG	25,045	4	0					2	140	26,101	4	0	2	146	26,610	4	0	2	148				
BLC3	17,395	0	0					4	97	18,129	0	0	4	101	18,482	0	0	4	103				
BLC4	17,966	0	0					4	100	18,724	0	0	5	104	19,089	0	0	5	107				
RCCO	17,552	1	0					4	98	18,293	1	0	4	102	18,649	1	0	4	104				
LCCO	17,552	1	0					4	98	18,293	1	0	4	102	18,649	1	0	4	104				
AFR	25,520	3	0					3	142	26,597	3	0	3	148	27,116	3	0	3	151				
P3	219W	80	850					T1S	30,127	3	0	4	137	31,398	3	0	4	143	32,010	3	0	4	146
								T2M	27,908	3	0	5	127	29,085	3	0	5	133	29,652	3	0	5	135
				T3M	28,232	3	0	5	129	29,423	3	0	5	134	29,996	3	0	5	137				
				T3LG	25,218	3	0	3	115	26,282	3	0	3	120	26,794	3	0	3	122				
				T4M	28,652	3	0	5	131	29,861	3	0	5	136	30,443	3	0	5	139				
				T4LG	26,059	3	0	3	119	27,159	3	0	3	124	27,688	3	0	3	126				
				TFTM	28,851	3	0	5	132	30,068	3	0	5	137	30,654	3	0	5	140				
				T5M	29,479	5	0	4	134	30,723	5	0	4	140	31,322	5	0	4	143				
				T5W	29,957	5	0	4	137	31,221	5	0	4	142	31,830	5	0	4	145				
				T5LG	29,565	4	0	2	135	30,812	5	0	2	140	31,413	5	0	2	143				
				BLC3	20,535	0	0	4	94	21,401	0	0	4	98	21,818	0	0	4	99				
				BLC4	21,209	0	0	5	97	22,104	0	0	5	101	22,534	0	0	5	103				
				RCCO	20,720	1	0	4	94	21,594	1	0	4	98	22,015	1	0	4	100				
				LCCO	20,720	1	0	4	94	21,594	1	0	4	98	22,015	1	0	4	100				
				AFR	30,127	3	0	4	137	31,398	3	0	4	143	32,010	3	0	4	146				
				P4	273W	80	1050	T1S	35,879	3	0	4	132	37,392	3	0	4	137	38,121	3	0	4	140
								T2M	33,236	3	0	5	122	34,638	3	0	5	127	35,313	3	0	5	130
T3M	33,622	3	0					5	123	35,040	3	0	5	129	35,723	3	0	5	131				
T3LG	30,033	3	0					4	110	31,300	3	0	4	115	31,910	3	0	4	117				
T4M	34,123	3	0					5	125	35,562	3	0	5	130	36,255	3	0	5	133				
T4LG	31,035	3	0					4	114	32,344	3	0	4	119	32,974	3	0	4	121				
TFTM	34,359	3	0					5	126	35,808	3	0	5	131	36,506	3	0	5	134				
T5M	35,108	5	0					4	129	36,589	5	0	4	134	37,302	5	0	4	137				
T5W	35,677	5	0					4	131	37,182	5	0	5	136	37,907	5	0	5	139				
T5LG	35,209	5	0					3	129	36,695	5	0	3	135	37,410	5	0	3	137				
BLC3	24,456	0	0					4	90	25,487	0	0	4	93	25,984	0	0	5	95				
BLC4	25,258	0	0					5	93	26,324	0	0	5	97	26,837	0	0	5	98				
RCCO	24,676	1	0					4	91	25,717	1	0	4	94	26,218	1	0	4	96				
LCCO	24,676	1	0					4	91	25,717	1	0	4	94	26,218	1	0	4	96				
AFR	35,879	3	0					4	132	37,392	3	0	4	137	38,121	3	0	4	140				

Performance Data

Lumen Output

Lumen values are from photometric tests performed in accordance with IESNA LM-79-08. Data is considered to be representative of configurations shown within the tolerances described within LM-79. Contact factory for performance data on any configurations not shown here.

Forward Optics																							
Performance Package	System Watts	LED Count	Drive Current (mA)	Distribution Type	30K					40K					50K								
					(3000K, 70 CRI)					(4000K, 70 CRI)					(5000K, 70 CRI)								
					Lumens	B	U	G	LPW	Lumens	B	U	G	LPW	Lumens	B	U	G	LPW				
P5	327W	80	1250	T1S	41,149	3	0	4	126	42,885	3	0	4	131	43,721	3	0	4	134				
				T2M	38,118	4	0	5	117	39,727	4	0	5	122	40,501	4	0	5	124				
				T3M	38,561	3	0	5	118	40,187	3	0	5	123	40,971	3	0	5	125				
				T3LG	34,445	3	0	4	105	35,898	3	0	4	110	36,598	3	0	4	112				
				T4M	39,135	3	0	5	120	40,786	3	0	5	125	41,581	3	0	5	127				
				T4LG	35,594	3	0	4	109	37,095	3	0	4	114	37,818	3	0	4	116				
				TFTM	39,406	3	0	5	121	41,069	3	0	5	126	41,869	3	0	5	128				
				T5M	40,265	5	0	4	123	41,964	5	0	4	128	42,782	5	0	5	131				
				T5W	40,918	5	0	5	125	42,644	5	0	5	131	43,475	5	0	5	133				
				T5LG	40,382	5	0	3	124	42,085	5	0	3	129	42,906	5	0	3	131				
				BLC3	28,048	0	0	5	86	29,231	0	0	5	90	29,801	0	0	5	91				
				BLC4	28,969	0	0	5	89	30,191	0	0	5	92	30,779	0	0	5	94				
				RCCO	28,301	2	0	5	87	29,495	2	0	5	90	30,070	2	0	5	92				
				LCCO	28,301	2	0	5	87	29,495	2	0	5	90	30,070	2	0	5	92				
				AFR	41,149	3	0	4	126	42,885	3	0	4	131	43,721	3	0	4	134				
				P6	342W	100	1050	T1S	45,968	3	0	4	135	47,907	3	0	5	140	48,841	3	0	5	143
								T2M	42,582	4	0	5	125	44,379	4	0	5	130	45,244	4	0	5	132
T3M	43,076	4	0					5	126	44,894	4	0	5	131	45,769	4	0	5	134				
T3LG	38,479	3	0					4	113	40,102	3	0	4	117	40,884	3	0	4	120				
T4M	43,719	4	0					5	128	45,563	4	0	5	133	46,451	4	0	5	136				
T4LG	39,762	3	0					4	116	41,439	3	0	4	121	42,247	3	0	4	124				
TFTM	44,021	3	0					5	129	45,878	4	0	5	134	46,772	4	0	5	137				
T5M	44,980	5	0					5	132	46,878	5	0	5	137	47,792	5	0	5	140				
T5W	45,710	5	0					5	134	47,638	5	0	5	139	48,566	5	0	5	142				
T5LG	45,111	5	0					3	132	47,014	5	0	3	138	47,930	5	0	3	140				
BLC3	31,333	0	0					5	92	32,655	0	0	5	96	33,291	0	0	5	97				
BLC4	32,361	0	0					5	95	33,726	0	0	5	99	34,384	0	0	5	101				
RCCO	31,615	2	0					5	93	32,949	2	0	5	96	33,591	2	0	5	98				
LCCO	31,615	2	0					5	93	32,949	2	0	5	96	33,591	2	0	5	98				
AFR	45,968	3	0					4	135	47,907	3	0	5	140	48,841	3	0	5	143				
P7	409W	100	1250					T1S	52,692	3	0	5	129	54,915	3	0	5	134	55,986	3	0	5	137
								T2M	48,811	4	0	5	119	50,871	4	0	5	124	51,862	4	0	5	127
				T3M	49,378	4	0	5	121	51,461	4	0	5	126	52,464	4	0	5	128				
				T3LG	44,107	3	0	4	108	45,968	3	0	4	112	46,864	3	0	5	115				
				T4M	50,114	4	0	5	122	52,228	4	0	5	128	53,246	4	0	5	130				
				T4LG	45,579	3	0	4	111	47,501	3	0	4	116	48,427	3	0	4	118				
				TFTM	50,460	4	0	5	123	52,589	4	0	5	129	53,614	4	0	5	131				
				T5M	51,560	5	0	5	126	53,735	5	0	5	131	54,783	5	0	5	134				
				T5W	52,396	5	0	5	128	54,607	5	0	5	133	55,671	5	0	5	136				
				T5LG	51,710	5	0	4	126	53,891	5	0	4	132	54,941	5	0	4	134				
				BLC3	35,916	1	0	5	88	37,431	1	0	5	91	38,161	1	0	5	93				
				BLC4	37,095	0	0	5	91	38,660	0	0	5	94	39,413	0	0	5	96				
				RCCO	36,240	2	0	5	89	37,769	2	0	5	92	38,505	2	0	5	94				
				LCCO	36,240	2	0	5	89	37,769	2	0	5	92	38,505	2	0	5	94				
				AFR	52,692	3	0	5	129	54,915	3	0	5	134	55,986	3	0	5	137				
				P8	462W	100	1400	T1S	57,662	3	0	5	125	60,094	4	0	5	130	61,266	4	0	5	132
								T2M	53,415	4	0	5	116	55,668	4	0	5	120	56,753	4	0	5	123
T3M	54,034	4	0					5	117	56,314	4	0	5	122	57,412	4	0	5	124				
T3LG	48,267	3	0					5	104	50,304	3	0	5	109	51,284	4	0	5	111				
T4M	54,840	4	0					5	119	57,154	4	0	5	124	58,268	4	0	5	126				
T4LG	49,877	3	0					5	108	51,981	3	0	5	112	52,994	3	0	5	115				
TFTM	55,219	4	0					5	119	57,549	4	0	5	124	58,671	4	0	5	127				
T5M	56,423	5	0					5	122	58,803	5	0	5	127	59,949	5	0	5	130				
T5W	57,338	5	0					5	124	59,757	5	0	5	129	60,921	5	0	5	132				
T5LG	56,586	5	0					4	122	58,974	5	0	4	128	60,123	5	0	4	130				
BLC3	39,303	1	0					5	85	40,962	1	0	5	89	41,760	1	0	5	90				
BLC4	40,593	0	0					5	88	42,306	0	0	5	91	43,130	0	0	5	93				
RCCO	39,658	2	0					5	86	41,331	2	0	5	89	42,137	2	0	5	91				
LCCO	39,658	2	0					5	86	41,331	2	0	5	89	42,137	2	0	5	91				
AFR	57,662	3	0					5	125	60,094	4	0	5	130	61,266	4	0	5	132				

Performance Data

Lumen Output

Lumen values are from photometric tests performed in accordance with IESNA LM-79-08. Data is considered to be representative of configurations shown within the tolerances described within LM-79. Contact factory for performance data on any configurations not shown here.

Rotated Optics																							
Performance Package	System Watts	LED Count	Drive Current (mA)	Distribution Type	30K					40K					50K								
					(3000K, 70 CRI)					(4000K, 70 CRI)					(5000K, 70 CRI)								
					Lumens	B	U	G	LPW	Lumens	B	U	G	LPW	Lumens	B	U	G	LPW				
P10	152W	90	530	T1S	22,798	4	0	4	150	23,760	4	0	4	156	24,223	4	0	4	159				
				T2M	21,119	5	0	5	139	22,010	5	0	5	145	22,439	5	0	5	148				
				T3M	21,361	5	0	5	141	22,262	5	0	5	147	22,696	5	0	5	149				
				T3LG	19,084	4	0	4	126	19,889	4	0	4	131	20,277	4	0	4	133				
				T4M	21,679	5	0	5	143	22,594	5	0	5	149	23,034	5	0	5	152				
				T4LG	19,717	4	0	4	130	20,549	4	0	4	135	20,950	4	0	4	138				
				TFTM	21,833	5	0	5	144	22,754	5	0	5	150	23,197	5	0	5	153				
				T5M	22,305	5	0	3	147	23,246	5	0	3	153	23,699	5	0	3	156				
				T5W	22,667	5	0	3	149	23,623	5	0	4	155	24,084	5	0	4	158				
				T5LG	22,370	4	0	2	147	23,314	4	0	2	153	23,768	4	0	2	156				
				BLC3	15,539	4	0	4	102	16,194	4	0	4	107	16,510	4	0	4	109				
				BLC4	16,048	4	0	4	106	16,725	4	0	4	110	17,051	4	0	4	112				
				RCCO	15,679	1	0	3	103	16,340	1	0	3	108	16,659	1	0	3	110				
				LCCO	15,679	1	0	3	103	16,340	1	0	3	108	16,659	1	0	3	110				
				AFR	22,798	4	0	4	150	23,760	4	0	4	156	24,223	4	0	4	159				
				P11	203W	90	700	T1S	29,222	4	0	4	144	30,455	4	0	4	150	31,048	4	0	4	153
								T2M	27,070	5	0	5	134	28,212	5	0	5	139	28,762	5	0	5	142
T3M	27,380	5	0					5	135	28,535	5	0	5	141	29,091	5	0	5	144				
T3LG	24,462	4	0					4	121	25,493	4	0	4	126	25,990	4	0	4	128				
T4M	27,788	5	0					5	137	28,960	5	0	5	143	29,525	5	0	5	146				
T4LG	25,273	4	0					4	125	26,339	4	0	4	130	26,853	4	0	4	133				
TFTM	27,985	5	0					5	138	29,165	5	0	5	144	29,734	5	0	5	147				
T5M	28,591	5	0					4	141	29,797	5	0	4	147	30,377	5	0	4	150				
T5W	29,054	5	0					4	143	30,280	5	0	4	149	30,870	5	0	4	152				
T5LG	28,673	4	0					2	142	29,883	4	0	2	148	30,465	5	0	2	150				
BLC3	19,917	4	0					4	98	20,757	4	0	4	102	21,162	4	0	4	104				
BLC4	20,570	5	0					5	102	21,437	5	0	5	106	21,855	5	0	5	108				
RCCO	20,097	1	0					4	99	20,945	1	0	4	103	21,353	1	0	4	105				
LCCO	20,097	1	0					4	99	20,945	1	0	4	103	21,353	1	0	4	105				
AFR	29,222	4	0					4	144	30,455	4	0	4	150	31,048	4	0	4	153				
P12	248W	90	850					T1S	34,526	5	0	5	139	35,983	5	0	5	145	36,684	5	0	5	148
								T2M	31,984	5	0	5	129	33,333	5	0	5	135	33,983	5	0	5	137
				T3M	32,350	5	0	5	131	33,715	5	0	5	136	34,372	5	0	5	139				
				T3LG	28,902	4	0	4	117	30,121	4	0	4	122	30,708	4	0	4	124				
				T4M	32,832	5	0	5	133	34,217	5	0	5	138	34,884	5	0	5	141				
				T4LG	29,861	4	0	4	121	31,120	4	0	4	126	31,727	5	0	4	128				
				TFTM	33,064	5	0	5	134	34,459	5	0	5	139	35,131	5	0	5	142				
				T5M	33,780	5	0	4	136	35,205	5	0	4	142	35,891	5	0	4	145				
				T5W	34,327	5	0	4	139	35,776	5	0	4	145	36,473	5	0	4	147				
				T5LG	33,878	5	0	3	137	35,307	5	0	3	143	35,995	5	0	3	145				
				BLC3	23,532	5	0	5	95	24,525	5	0	5	99	25,003	5	0	5	101				
				BLC4	24,303	5	0	5	98	25,328	5	0	5	102	25,822	5	0	5	104				
				RCCO	23,745	1	0	4	96	24,747	1	0	4	100	25,229	1	0	4	102				
				LCCO	23,745	1	0	4	96	24,747	1	0	4	100	25,229	1	0	4	102				
				AFR	34,526	5	0	5	139	35,983	5	0	5	145	36,684	5	0	5	148				

Performance Data

Lumen Output

Lumen values are from photometric tests performed in accordance with IESNA LM-79-08. Data is considered to be representative of configurations shown within the tolerances described within LM-79. Contact factory for performance data on any configurations not shown here.

Rotated Optics																			
Performance Package	System Watts	LED Count	Drive Current (mA)	Distribution Type	30K					40K					50K				
					(3000K, 70 CRI)					(4000K, 70 CRI)					(5000K, 70 CRI)				
					Lumens	B	U	G	LPW	Lumens	B	U	G	LPW	Lumens	B	U	G	LPW
P13	354W	90	1200	T1S	45,748	5	0	5	129	47,678	5	0	5	135	48,608	5	0	5	137
				T2M	42,380	5	0	5	120	44,168	5	0	5	125	45,029	5	0	5	127
				T3M	42,865	5	0	5	121	44,673	5	0	5	126	45,544	5	0	5	129
				T3LG	38,296	5	0	5	108	39,911	5	0	5	113	40,689	5	0	5	115
				T4M	43,503	5	0	5	123	45,339	5	0	5	128	46,222	5	0	5	131
				T4LG	39,566	5	0	5	112	41,235	5	0	5	117	42,039	5	0	5	119
				TFTM	43,811	5	0	5	124	45,659	5	0	5	129	46,549	5	0	5	132
				T5M	44,760	5	0	5	126	46,648	5	0	5	132	47,557	5	0	5	134
				T5W	45,485	5	0	5	129	47,404	5	0	5	134	48,328	5	0	5	137
				T5LG	44,889	5	0	3	127	46,783	5	0	3	132	47,695	5	0	3	135
				BLC3	31,181	5	0	5	88	32,496	5	0	5	92	33,130	5	0	5	94
				BLC4	32,202	5	0	5	91	33,561	5	0	5	95	34,215	5	0	5	97
				RCCO	31,463	2	0	5	89	32,790	2	0	5	93	33,429	2	0	5	94
				LCCO	31,463	2	0	5	89	32,790	2	0	5	93	33,429	2	0	5	94
				AFR	45,748	5	0	5	129	47,678	5	0	5	135	48,608	5	0	5	137
				P14	415W	90	1400	T1S	51,272	5	0	5	123	53,435	5	0	5	129	54,476
T2M	47,497	5	0					5	114	49,500	5	0	5	119	50,465	5	0	5	121
T3M	48,040	5	0					5	116	50,067	5	0	5	121	51,043	5	0	5	123
T3LG	42,919	5	0					5	103	44,730	5	0	5	108	45,602	5	0	5	110
T4M	48,756	5	0					5	117	50,813	5	0	5	122	51,803	5	0	5	125
T4LG	44,343	5	0					5	107	46,214	5	0	5	111	47,115	5	0	5	113
TFTM	49,101	5	0					5	118	51,172	5	0	5	123	52,169	5	0	5	126
T5M	50,164	5	0					5	121	52,280	5	0	5	126	53,299	5	0	5	128
T5W	50,977	5	0					5	123	53,127	5	0	5	128	54,163	5	0	5	130
T5LG	50,309	5	0					4	121	52,432	5	0	4	126	53,453	5	0	4	129
BLC3	34,945	5	0					5	84	36,420	5	0	5	88	37,130	5	0	5	89
BLC4	36,090	5	0					5	87	37,613	5	0	5	91	38,346	5	0	5	92
RCCO	35,261	2	0					5	85	36,749	2	0	5	88	37,465	2	0	5	90
LCCO	35,261	2	0					5	85	36,749	2	0	5	88	37,465	2	0	5	90
AFR	51,272	5	0					5	123	53,435	5	0	5	129	54,476	5	0	5	131

Dimensions

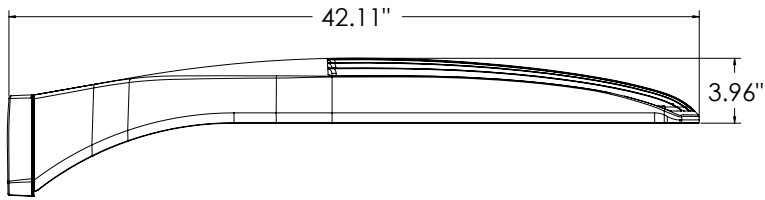

DSX2 with RPA, RPA5, SPA5, SPA8N mount
Weight: 48 lbs

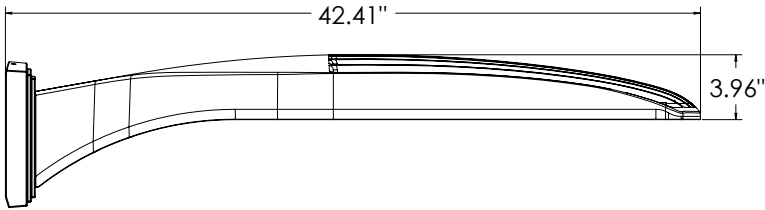
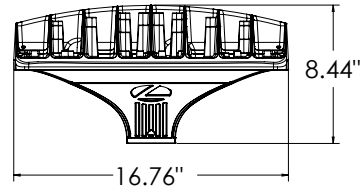

DSX2 with WBA mount
Weight: 50 lbs

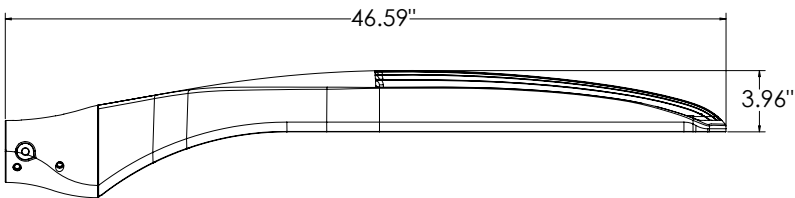
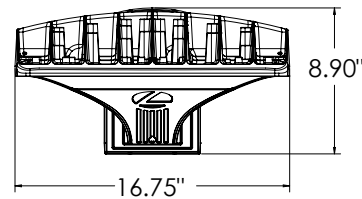

DSX2 with MA mount
Weight: 50 lbs

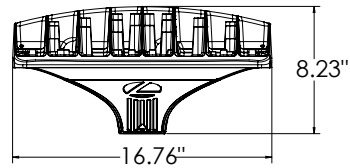

SPA (STANDARD ARM)

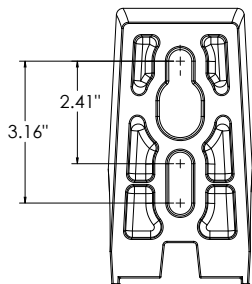

RPA

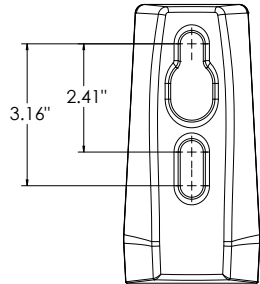

SPA5

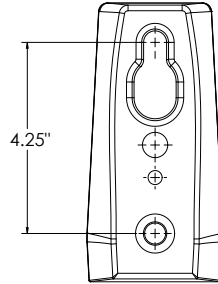

RPA5

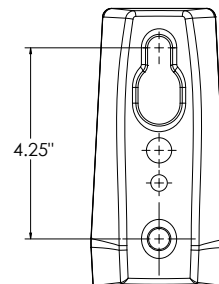

SPA8N

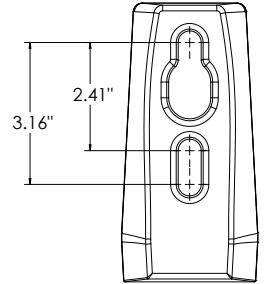

nLight Sensor Coverage Pattern

NLTAIR2 PIRHN

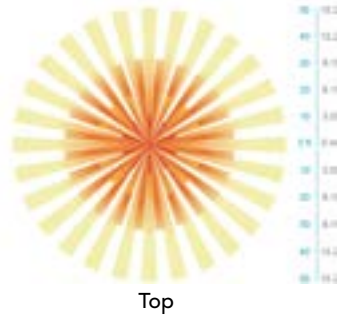

FEATURES & SPECIFICATIONS

INTENDED USE

The sleek design of the D-Series Area Size 2 reflects the embedded high performance LED technology. It is ideal for applications like car dealerships and large parking lots adjacent to malls, transit stations, grocery stores, home centers, and other big-box retailers.

CONSTRUCTION

Single-piece die-cast aluminum housing has integral heat sink fins to optimize thermal management through conductive and convective cooling. Modular design allows for ease of maintenance and future light engine upgrades. The LED drivers are mounted in direct contact with the casting to promote low operating temperature and long life. Housing driver compartment is completely sealed against moisture and environmental contaminants (IP66). Vibration rated per ANSI C136.31 for 1.5G. 3G vibration rated available for (MA) mast arm mount when specifying option 3G. Low EPA (1.06 ft²) for optimized pole wind loading.

FINISH

Exterior parts are protected by a zinc-infused Super Durable TGIC thermoset powder coat finish that provides superior resistance to corrosion and weathering. A tightly controlled multi-stage process ensures a minimum 3 mils thickness for a finish that can withstand extreme climate changes without cracking or peeling. Available in both textured and non-textured finishes.

Coastal Construction (CCE)

Optional corrosion resistant construction is engineered with added corrosion protection in materials and/or pre-treatment of base material under super durable paint. Provides additional corrosion protection for applications near coastal areas. Finish is salt spray tested to over 5,000 hours per ASTM B117 with scribe rating of 10. Additional lead-times may apply.

OPTICS

Precision-molded proprietary silicone lenses are engineered for superior area lighting distribution, uniformity, and pole spacing. Light engines are available in 3000 K, 4000 K, or 5000 K (70 CRI) configurations. 80CRI configurations are also available. The D-Series Size 2 has zero uplight and qualifies as a Nighttime Friendly™ product, meaning it is consistent with the LEED® and Green Globes™ criteria for eliminating wasteful uplight.

ELECTRICAL

Light engine configurations consist of high-efficacy LEDs mounted to metal-core circuit boards to maximize heat dissipation and promote long life (up to L82/100,000 hrs at 25°C). Class 1 electronic drivers are designed to have a power factor >90%, THD <20%, and an expected life of 100,000 hours with <1% failure rate. Easily-serviceable 10kV surge protection device meets a minimum Category C Low operation (per ANSI/IEEE C62.41.2).

INSTALLATION

Integral mounting arm allows for fast mounting using Lithonia standard #8 drilling and accommodates pole drillings from 2.41 to 3.12" on center. The standard "SPA" option for square poles and the "RPA" option for round poles use the #8 drilling. For #5 pole drillings, use SPA5 or RPA5. Additional mountings are available including a wall bracket (WBA) and mast arm (MA) option that allows luminaire attachment to a 2 3/8" horizontal mast arm.

STANDARD CONTROLS

The DSX2 LED area luminaire has a number of control options. DSX Size 2, comes standard with 0-10V dimming drivers. Dusk to dawn controls can be utilized via optional NEMA twist-lock photocell receptacles. Integrated motion sensor with on-board photocells feature field-adjustable programming and are suitable for mounting heights up to 40 feet. Control option BL features a bi-level device that allows a second control circuit to switch all light engines to either 30% or 50% light output.

nLIGHT AIR CONTROLS

The DSX2 LED area luminaire is also available with nLight® AIR for the ultimate in wireless control. This powerful controls platform provides out-of-the-box basic motion sensing and photocontrol functionality and is suitable for mounting heights up to 40 feet. Once commissioned using a smartphone and the easy-to-use CLAIRITY app, nLight AIR equipped luminaires can be grouped, resulting in motion sensor and photocell group response without the need for additional equipment. Scheduled dimming with motion sensor over-ride can be achieved when used with the nLight Eclipse. Additional information about nLight Air can be found [here](#).

LISTINGS

UL listed to meet U.S. and Canadian standards. UL Listed for wet locations. Light engines are IP66 rated; luminaire is IP66 rated. Rated for -40°C minimum ambient.

DesignLights Consortium® (DLC) Premium qualified product and DLC qualified product. Not all versions of this product may be DLC Premium qualified or DLC qualified. Please check the DLC Qualified Products List at www.designlights.org/QPL to confirm which versions are qualified.

International Dark-Sky Association (IDA) Fixture Seal of Approval (FSA) is available for all products on this page utilizing 3000K color temperature only.

BUY AMERICAN ACT

Product with the BAA option is assembled in the USA and meets the Buy America(n) government procurement requirements under FAR, DFARS and DOT regulations. Please refer to www.acuitybrands.com/buy-american for additional information.

WARRANTY

5-year limited warranty. This is the only warranty provided and no other statements in this specification sheet create any warranty of any kind. All other express and implied warranties are disclaimed. Complete warranty terms located at: www.acuitybrands.com/support/warranty/terms-and-conditions

Note: Actual performance may differ as a result of end-user environment and application. All values are design or typical values, measured under laboratory conditions at 25 °C. Specifications subject to change without notice.



D-Series Size 1 LED Area Luminaire



d#series

Specifications

EPA:	0.69 ft ² (0.06 m ²)
Length:	32.71" (83.1 cm)
Width:	14.26" (36.2 cm)
Height H1:	7.88" (20.0 cm)
Height H2:	2.73" (6.9 cm)
Weight:	34 lbs (15.4 kg)

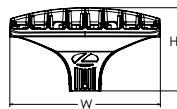
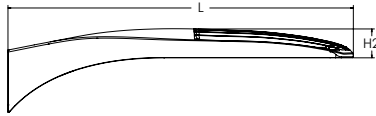
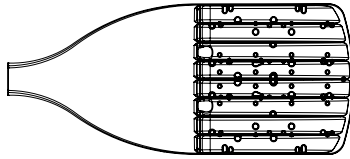

Catalog
Number

Notes

Type

Hit the Tab key or mouse over the page to see all interactive elements.

Introduction

The modern styling of the D-Series features a highly refined aesthetic that blends seamlessly with its environment. The D-Series offers the benefits of the latest in LED technology into a high performance, high efficacy, long-life luminaire.

The photometric performance results in sites with excellent uniformity, greater pole spacing and lower power density. D-Series outstanding photometry aids in reducing the number of poles required in area lighting applications with typical energy savings of 65% and expected service life of over 100,000 hours.

Ordering Information

EXAMPLE: DSX1 LED P7 40K 70CRI T3M MVOLT SPA NLTAIR2 PIRHN DDBXD

Series	LEDs	Color temperature ²	Color Rendering Index ²	Distribution	Voltage	Mounting
DSX1 LED	Forward optics P1 P6 P2 P7 P3 P8 P4 P9 P5 Rotated optics P10 ¹ P12 ¹ P11 ¹ P13 ¹	(this section 70CRI only) 30K 3000K 40K 4000K 50K 5000K (this section 80CRI only, extended lead times apply) 27K 2700K 30K 3000K 35K 3500K 40K 4000K 50K 5000K	70CRI 70CRI 70CRI 80CRI 80CRI 80CRI 80CRI	AFR Automotive front row T1S Type I short T2M Type II medium T3M Type III medium T3LG Type III low glare ³ T4M Type IV medium T4LG Type IV low glare ³ TFTM Forward throw medium T5M Type V medium T5LG Type V low glare T5W Type V wide BLC3 Type III backlight control ³ BLC4 Type IV backlight control ³ LCCO Left corner cutoff ³ RCCO Right corner cutoff ³	MVOLT (120V-277V) ⁴ HVOLT (347V-480V) ^{5,6} XVOLT (277V - 480V) ^{7,8} 120 ^{16,26} 208 ^{16,26} 240 ^{16,26} 277 ^{16,26} 347 ^{16,26} 480 ^{16,26}	Shipped included SPA Square pole mounting (#8 drilling) RPA Round pole mounting (#8 drilling) SPA5 Square pole mounting #5 drilling ⁹ RPA5 Round pole mounting #5 drilling ⁹ SPA8N Square narrow pole mounting #8 drilling WBA Wall bracket ¹⁰ MA Mast arm adapter (mounts on 2 3/8" OD horizontal tenon)

Control options	Other options	Finish (required)	
Shipped installed NLTAIR2 PIRHN nLight AIR gen 2 enabled with bi-level motion / ambient sensor, 8-40' mounting height, ambient sensor enabled at 2fc. ^{11,12,20,21} PIR High/low, motion/ambient sensor, 8-40' mounting height, ambient sensor enabled at 2fc. ^{13,20,21} PER NEMA twist-lock receptacle only (controls ordered separately) ¹⁴ PERS Five-pin receptacle only (controls ordered separate) ^{14,21}	PER7 Seven-pin receptacle only (controls ordered separate) ^{14,21} FAO Field adjustable output ^{15,21} BL30 Bi-level switched dimming, 30% ^{16,21} BL50 Bi-level switched dimming, 50% ^{16,21} DMG 0-10v dimming wires pulled outside fixture (for use with an external control, ordered separately) ¹⁷ DS Dual switching ^{18,19,21}	Shipped installed SPD20KV 20KV surge protection HS Houseside shield (black finish standard) ²² L90 Left rotated optics ¹ R90 Right rotated optics ¹ CCE Coastal Construction ²³ HA 50°C ambient operation ²⁴ BAA Buy America(n) Act Compliant SF Single fuse (120, 277, 347V) ²⁶ DF Double fuse (208, 240, 480V) ²⁶ Shipped separately EGSR External Glare Shield (reversible, field install required, matches housing finish) BSDB Bird Spikes (field install required)	DDBXD Dark Bronze DBLXD Black DNAXD Natural Aluminum DWHXD White DDBTXD Textured dark bronze DBLBXD Textured black DNATXD Textured natural aluminum DWHGXD Textured white



Ordering Information

Accessories

Ordered and shipped separately.

DLL127F 1.5 JU	Photocell - SSL twist-lock (120-277V) ²⁵
DLL347F 1.5 CUL JU	Photocell - SSL twist-lock (347V) ²⁵
DLL480F 1.5 CUL JU	Photocell - SSL twist-lock (480V) ²⁵
DSHORT SBK	Shorting cap ²⁵
DSX1HS P#	House-side shield (enter package number 1-13 in place of #)
DSXRPA (FINISH)	Round pole adapter (#8 drilling, specify finish)
DSXSPA5 (FINISH)	Square pole adapter #5 drilling (specify finish)
DSXRPA5 (FINISH)	Round pole adapter #5 drilling (specify finish)
DSX1EGSR (FINISH)	External glare shield (specify finish)
DSX1BSDB (FINISH)	Bird spike deterrent bracket (specify finish)

NOTES

- 1 Rotated optics available with packages P10, P11, P12 and P13. Must be combined with option L90 or R90.
- 2 30K, 40K, and 50K available in 70CRI and 80CRI. 27K and 35K only available with 80CRI. Contact Technical Support for other possible combinations.
- 3 T3LG, T4LG, BLC3, BLC4, LCCO, RCCO not available with option HS.
- 4 MVOLT driver operates on any line voltage from 120-277V (50/60 Hz).
- 5 HVOLT driver operates on any line voltage from 347-480V (50/60 Hz).
- 6 HVOLT not available with package P1 and P10 when combined with option NLTAIR2 PIRHN or option PIR.
- 7 XVOLT operates with any voltage between 277V and 480V (50/60 Hz).
- 8 XVOLT not available in packages P1 or P10. XVOLT not available with fusing (SF or DF).
- 9 SPA5 and RPA5 for use with #5 drilling only (Not for use with #8 drilling).
- 10 WBA cannot be combined with Type 5 distributions plus photocell (PER).
- 11 NLTAIR2 and PIRHN must be ordered together. For more information on nLight AIR2 visit this [link](#).
- 12 NLTAIR2 PIRHN not available with other controls including PIR, PER, PER5, PER7, FAO, BL30, BL50, DMG and DS. NLTAIR2 PIRHN not available with P1 and P10 using HVOLT. NLTAIR2 PIRHN not available with P1 and P10 using XVOLT.
- 13 PIR not available with NLTAIR2 PIRHN, PER, PER5, PER7, FAO BL30, BL50, DMG and DS. PIR not available with P1 and P10 using HVOLT. PIR not available with P1 and P10 using XVOLT.
- 14 PER/PER5/PER7 not available with NLTAIR2 PIRHN, PIR, BL30, BL50, FAO, DMG and DS. Photocell ordered and shipped as a separate line item from Acuity Brands Controls. See accessories. Shorting Cap included.
- 15 FAO not available with other dimming control options NLTAIR2 PIRHN, PIR, PER5, PER7, BL30, BL50, DMG and DS.
- 16 BL30 and BL50 are not available with NLTAIR2 PIRHN, PIR, PER, PER5, PER7, FAO, DMG and DS. BL30 or BL50 must specify 120, 277 or 347V. Consult tech support for 208, 240 or 480V.
- 17 DMG not available with NLTAIR2 PIRHN, PIR, PER, PER5, PER7, BL30, BL50, FAO and DS.
- 18 DS not available with NLTAIR2 PIRHN, PIR, PER, PER5, PER7, BL30, BL50, FAO and DMG.
- 19 DS requires (2) separately switched circuits. DS provides 50/50 fixture operation via (2) different sets of leads using (2) drivers. DS only available with packages P8, P9, P10, P11, P12 and P13.
- 20 Reference Motion Sensor Default Settings table on page 4 to see functionality.
- 21 Reference Controls Options table on page 4.
- 22 HS not available with T3LG, T4LG, BLC3, BLC4, LCCO and RCCO distribution. Also available as a separate accessory; see Accessories information.
- 23 CCE option not available with option BS and EGSR. Contact Technical Support for availability.
- 24 Option HA not available with performance packages P4, P5, P7, P8, P9 and P13.
- 25 Requires luminaire to be specified with PER, PER5 or PER7 option. See Controls Table on page 4.
- 26 Single fuse (SF) requires 120V, 277V, or 347V. Double fuse (DF) requires 208V, 240V or 480V. XVOLT not available with fusing (SF or DF).

Shield Accessories



External Glare Shield (EGSR)

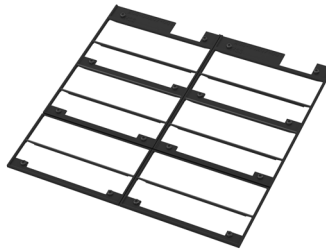

House Side Shield (HS)

Drilling

HANDHOLE ORIENTATION

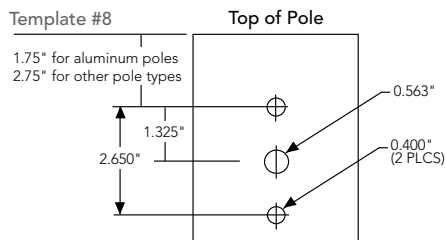
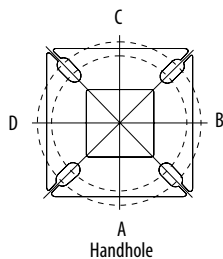

Tenon Mounting Slipfitter

Tenon O.D.	Mounting	Single Unit	2 @ 180	2 @ 90	3 @ 90	3 @ 120	4 @ 90
2-3/8"	RPA	AS3-5 190	AS3-5 280	AS3-5 290	AS3-5 390	AS3-5 320	AS3-5 490
2-7/8"	RPA	AST25-190	AST25-280	AST25-290	AST25-390	AST25-320	AST25-490
4"	RPA	AST35-190	AST35-280	AST35-290	AST35-390	AST35-320	AST35-490

Mounting Option	Drilling Template	Single	2 @ 180	2 @ 90	3 @ 90	3 @ 120	4 @ 90
Head Location		Side B	Side B & D	Side B & C	Side B, C & D	Round Pole Only	Side A, B, C & D
Drill Nomenclature	#8	DM19AS	DM28AS	DM29AS	DM39AS	DM32AS	DM49AS
Minimum Acceptable Outside Pole Dimension							
SPA	#8	3.5"	3.5"	3.5"	3.5"		3.5"
RPA	#8	3"	3"	3"	3"	3"	3"
SPA5	#5	3"	3"	3"	3"		3"
RPA5	#5	3"	3"	3"	3"	3"	3"
SPA8N	#8	3"	3"	3"	3"		3"

DSX1 Area Luminaire - EPA

*Includes luminaire and integral mounting arm. Other tenons, arms, brackets or other accessories are not included in this EPA data.

Fixture Quantity & Mounting Configuration	Single DM19	2 @ 180 DM28	2 @ 90 DM29	3 @ 90 DM39	3 @ 120 DM32	4 @ 90 DM49
Mounting Type						
DSX1 with SPA	0.69	1.38	1.23	1.54	---	1.58
DSX1 with SPA5, SPA8N	0.70	1.40	1.30	1.66	---	1.68
DSX1 with RPA, RPA5	0.70	1.40	1.30	1.66	1.60	1.68
DSX1 with MA	0.83	1.66	1.50	2.09	2.09	2.09

Photometric Diagrams

To see complete photometric reports or download .ies files for this product, visit Lithonia Lighting's [homepage](#).

Isofootcandle plots for the DSX1 LED P9 40K 70CRI. Distances are in units of mounting height (25').



Performance Data

Lumen Ambient Temperature (LAT) Multipliers

Use these factors to determine relative lumen output for average ambient temperatures from 0-40°C (32-104°F).

Ambient		Lumen Multiplier
0°C	32°F	1.04
5°C	41°F	1.04
10°C	50°F	1.03
15°C	59°F	1.02
20°C	68°F	1.01
25°C	77°C	1.00
30°C	86°F	0.99
35°C	95°F	0.98
40°C	104°F	0.97

Projected LED Lumen Maintenance

Data references the extrapolated performance projections for the platforms noted in a **25°C ambient**, based on 10,000 hours of LED testing (tested per IESNA LM-80-08 and projected per IESNA TM-21-11).

To calculate LLF, use the lumen maintenance factor that corresponds to the desired number of operating hours below. For other lumen maintenance values, contact factory.

Operating Hours	Lumen Maintenance Factor
0	1.00
25,000	0.95
50,000	0.90
100,000	0.81

FAO Dimming Settings

FAO Position	% Wattage	% Lumen Output
8	100%	100%
7	93%	95%
6	80%	85%
5	66%	73%
4	54%	61%
3	41%	49%
2	29%	36%
1	15%	20%

*Note: Calculated values are based on original performance package data. When calculating new values for given FAO position, use maximum published values by package listed on specification sheet (input watts and lumens by optic type).

Electrical Load

	Performance Package	LED Count	Drive Current (mA)	Wattage	Current (A)					
					120V	208V	240V	277V	347V	480V
Forward Optics (Non-Rotated)	P1	30	530	51	0.42	0.24	0.21	0.18	0.15	0.11
	P2	30	700	68	0.56	0.33	0.28	0.24	0.20	0.14
	P3	30	1050	104	0.85	0.49	0.43	0.37	0.29	0.21
	P4	30	1250	125	1.03	0.60	0.52	0.45	0.36	0.26
	P5	30	1400	142	1.15	0.66	0.58	0.50	0.40	0.29
	P6	40	1250	167	1.38	0.79	0.69	0.60	0.48	0.34
	P7	40	1400	188	1.54	0.89	0.77	0.67	0.53	0.38
	P8	60	1100	216	1.80	1.04	0.90	0.78	0.62	0.45
	P9	60	1400	279	2.31	1.33	1.15	1.00	0.80	0.58
Rotated Optics (Requires L90 or R90)	P10	60	530	101	0.84	0.49	0.42	0.37	0.29	0.21
	P11	60	700	135	1.12	0.65	0.56	0.49	0.39	0.28
	P12	60	1050	206	1.72	0.99	0.86	0.74	0.59	0.43
	P13	60	1400	279	2.30	1.33	1.15	1.00	0.79	0.57

LED Color Temperature / Color Rendering Multipliers

	70 CRI		80CRI		90CRI	
	Lumen Multiplier	Availability	Lumen Multiplier	Availability	Lumen Multiplier	Availability
5000K	102%	Standard	92%	Extended lead-time	71%	(see note)
4000K	100%	Standard	92%	Extended lead-time	67%	(see note)
3500K	100%	(see note)	90%	Extended lead-time	63%	(see note)
3000K	96%	Standard	87%	Extended lead-time	61%	(see note)
2700K	94%	(see note)	85%	Extended lead-time	57%	(see note)

Note: Some LED types are available as per special request. Contact Technical Support for more information.

Motion Sensor Default Settings

Option	Unoccupied Dimmed Level	High Level (when occupied)	Photocell Operation	Dwell Time	Ramp-up Time	Dimming Fade Rate
PIR	30%	100%	Enabled @ 2FC	7.5 min	3 sec	5 min
NLTAIR2 PIRHN	30%	100%	Enabled @ 2FC	7.5 min	3 sec	5 min

Controls Options

Nomenclature	Description	Functionality	Primary control device	Notes
FAO	Field adjustable output device installed inside the luminaire; wired to the driver dimming leads.	Allows the luminaire to be manually dimmed, effectively trimming the light output.	FAO device	Cannot be used with other controls options that need the 0-10V leads
DS (not available on DSX0)	Drivers wired independently for 50/50 luminaire operation	The luminaire is wired to two separate circuits, allowing for 50/50 operation.	Independently wired drivers	Requires two separately switched circuits. Consider nLight AIR as a more cost effective alternative.
PERS or PER7	Twist-lock photocell receptacle	Compatible with standard twist-lock photocells for dusk to dawn operation, or advanced control nodes that provide 0-10V dimming signals.	Twist-lock photocells such as DLL Elite or advanced control nodes such as ROAM.	Pins 4 & 5 to dimming leads on driver, Pins 6 & 7 are capped inside luminaire. Cannot be used with other controls options that need the 0-10V leads.
PIR	Motion sensor with integral photocell. Sensor suitable for 8' to 40' mounting height.	Luminaires dim when no occupancy is detected.	Acuity Controls rSBG	Cannot be used with other controls options that need the 0-10V leads.
NLTAIR2 PIRHN	nLight AIR enabled luminaire for motion sensing, photocell and wireless communication.	Motion and ambient light sensing with group response. Scheduled dimming with motion sensor over-ride when wirelessly connected to the nLight Elypse.	nLight Air rSBG	nLight AIR sensors can be programmed and commissioned from the ground using the CIAIRity Pro app. Cannot be used with other controls options that need the 0-10V leads.
BL30 or BL50	Integrated bi-level device that allows a second control circuit to switch all light engines to either 30% or 50% light output	BLC device provides input to 0-10V dimming leads on all drivers providing either 100% or dimmed (30% or 50%) control by a secondary circuit	BLC UVOLT1	BLC device is powered off the 0-10V dimming leads, thus can be used with any input voltage from 120 to 480V



Performance Data

Lumen Output

Lumen values are from photometric tests performed in accordance with IESNA LM-79-08. Data is considered to be representative of configurations shown within the tolerances described within LM-79. Contact factory for performance data on any configurations not shown here.

Forward Optics																							
Performance Package	System Watts	LED Count	Drive Current (mA)	Distribution Type	30K					40K					50K								
					(3000K, 70 CRI)					(4000K, 70 CRI)					(5000K, 70 CRI)								
					Lumens	B	U	G	LPW	Lumens	B	U	G	LPW	Lumens	B	U	G	LPW				
P1	51W	30	530	T1S	7,776	1	0	2	153	8,104	1	0	2	159	8,262	1	0	2	162				
				T2M	7,203	1	0	3	142	7,507	2	0	3	147	7,653	2	0	3	150				
				T3M	7,287	1	0	3	143	7,594	1	0	3	149	7,742	1	0	3	152				
				T3LG	6,509	1	0	1	128	6,783	1	0	1	133	6,916	1	0	1	136				
				T4M	7,395	1	0	3	145	7,707	1	0	3	151	7,857	1	0	3	154				
				T4LG	6,726	1	0	1	132	7,010	1	0	1	138	7,146	1	0	1	140				
				TFTM	7,446	1	0	3	146	7,760	1	0	3	152	7,912	1	0	3	155				
				T5M	7,609	3	0	2	149	7,930	3	0	2	156	8,084	3	0	2	159				
				T5W	7,732	3	0	2	152	8,058	4	0	2	158	8,215	4	0	2	161				
				T5LG	7,631	3	0	1	150	7,953	3	0	1	156	8,108	3	0	1	159				
				BLC3	5,300	0	0	2	104	5,524	0	0	2	109	5,631	0	0	2	111				
				BLC4	5,474	0	0	3	108	5,705	0	0	3	112	5,816	0	0	3	114				
				RCCO	5,348	0	0	2	105	5,573	0	0	2	109	5,682	0	0	2	112				
				LCCO	5,348	0	0	2	105	5,573	0	0	2	109	5,682	0	0	2	112				
				AFR	7,776	1	0	2	153	8,104	1	0	2	159	8,262	1	0	2	162				
				P2	68W	30	700	T1S	9,997	1	0	2	147	10,418	1	0	2	154	10,621	1	0	2	157
								T2M	9,260	2	0	3	137	9,651	2	0	3	142	9,839	2	0	3	145
T3M	9,368	2	0					3	138	9,763	2	0	3	144	9,953	2	0	3	147				
T3LG	8,368	1	0					2	123	8,721	1	0	2	129	8,891	1	0	2	131				
T4M	9,507	2	0					3	140	9,909	2	0	3	146	10,102	2	0	3	149				
T4LG	8,647	1	0					2	128	9,012	1	0	2	133	9,187	1	0	2	136				
TFTM	9,573	2	0					3	141	9,977	2	0	3	147	10,172	2	0	3	150				
T5M	9,782	4	0					2	144	10,195	4	0	2	150	10,393	4	0	2	153				
T5W	9,940	4	0					2	147	10,360	4	0	2	153	10,562	4	0	2	156				
T5LG	9,810	3	0					1	145	10,224	3	0	1	151	10,423	3	0	1	154				
BLC3	6,814	0	0					2	101	7,101	0	0	2	105	7,240	0	0	2	107				
BLC4	7,038	0	0					3	104	7,334	0	0	3	108	7,477	0	0	3	110				
RCCO	6,875	1	0					2	101	7,165	1	0	2	106	7,305	1	0	2	108				
LCCO	6,875	1	0					2	101	7,165	1	0	2	106	7,305	1	0	2	108				
AFR	9,997	1	0					2	147	10,418	1	0	2	154	10,621	1	0	2	157				
P3	102W	30	1050					T1S	14,093	2	0	2	138	14,687	2	0	2	144	14,973	2	0	2	147
								T2M	13,055	2	0	3	128	13,605	2	0	3	133	13,871	2	0	3	136
				T3M	13,206	2	0	4	129	13,763	2	0	4	135	14,031	2	0	4	137				
				T3LG	11,797	2	0	2	115	12,294	2	0	2	120	12,534	2	0	2	123				
				T4M	13,403	2	0	4	131	13,968	2	0	4	137	14,241	2	0	4	139				
				T4LG	12,190	2	0	2	119	12,704	2	0	2	124	12,952	2	0	2	127				
				TFTM	13,496	2	0	4	132	14,065	2	0	4	138	14,339	2	0	4	140				
				T5M	13,790	4	0	2	135	14,371	4	0	2	141	14,652	4	0	2	143				
				T5W	14,013	4	0	3	137	14,605	4	0	3	143	14,889	4	0	3	146				
				T5LG	13,830	3	0	2	135	14,413	3	0	2	141	14,694	3	0	2	144				
				BLC3	9,606	0	0	2	94	10,011	0	0	2	98	10,206	0	0	2	100				
				BLC4	9,921	0	0	3	97	10,340	0	0	3	101	10,541	0	0	3	103				
				RCCO	9,692	1	0	2	95	10,101	1	0	2	99	10,298	1	0	2	101				
				LCCO	9,692	1	0	2	95	10,101	1	0	2	99	10,298	1	0	2	101				
				AFR	14,093	2	0	2	138	14,687	2	0	2	144	14,973	2	0	2	147				

Performance Data

Lumen Output

Lumen values are from photometric tests performed in accordance with IESNA LM-79-08. Data is considered to be representative of configurations shown within the tolerances described within LM-79. Contact factory for performance data on any configurations not shown here.

Forward Optics

Performance Package	System Watts	LED Count	Drive Current (mA)	Distribution Type	30K					40K					50K								
					(3000K, 70 CRI)					(4000K, 70 CRI)					(5000K, 70 CRI)								
					Lumens	B	U	G	LPW	Lumens	B	U	G	LPW	Lumens	B	U	G	LPW				
P4	124W	30	1250	T1S	16,416	2	0	3	132	17,109	2	0	3	138	17,442	2	0	3	141				
				T2M	15,207	3	0	4	123	15,849	3	0	4	128	16,158	3	0	4	130				
				T3M	15,383	2	0	4	124	16,032	2	0	4	129	16,345	2	0	4	132				
				T3LG	13,742	2	0	2	111	14,321	2	0	2	116	14,600	2	0	2	118				
				T4M	15,613	2	0	4	126	16,272	2	0	4	131	16,589	2	0	4	134				
				T4LG	14,200	2	0	2	115	14,799	2	0	2	119	15,087	2	0	2	122				
				TFTM	15,721	2	0	4	127	16,384	2	0	4	132	16,703	2	0	4	135				
				T5M	16,063	4	0	2	130	16,741	4	0	2	135	17,067	4	0	2	138				
				T5W	16,324	5	0	3	132	17,013	5	0	3	137	17,344	5	0	3	140				
				T5LG	16,110	3	0	2	130	16,790	4	0	2	135	17,117	4	0	2	138				
				BLC3	11,190	0	0	3	90	11,662	0	0	3	94	11,889	0	0	3	96				
				BLC4	11,557	0	0	3	93	12,044	0	0	3	97	12,279	0	0	4	99				
				RCCO	11,291	1	0	3	91	11,767	1	0	3	95	11,996	1	0	3	97				
				LCCO	11,291	1	0	3	91	11,767	1	0	3	95	11,996	1	0	3	97				
				AFR	16,416	2	0	3	132	17,109	2	0	3	138	17,442	2	0	3	141				
				P5	138W	30	1400	T1S	18,052	2	0	3	131	18,814	2	0	3	136	19,180	2	0	3	139
								T2M	16,723	3	0	4	121	17,428	3	0	4	126	17,768	3	0	4	129
T3M	16,917	3	0					4	122	17,630	3	0	4	128	17,974	3	0	4	130				
T3LG	15,111	2	0					2	109	15,749	2	0	2	114	16,055	2	0	2	116				
T4M	17,169	3	0					5	124	17,893	3	0	5	130	18,242	3	0	5	132				
T4LG	15,615	2	0					2	113	16,274	2	0	2	118	16,591	2	0	2	120				
TFTM	17,288	2	0					4	125	18,017	2	0	5	130	18,368	3	0	5	133				
T5M	17,664	5	0					3	128	18,410	5	0	3	133	18,768	5	0	3	136				
T5W	17,951	5	0					3	130	18,708	5	0	3	135	19,073	5	0	3	138				
T5LG	17,716	4	0					2	128	18,463	4	0	2	134	18,823	4	0	2	136				
BLC3	12,305	0	0					3	89	12,824	0	0	3	93	13,074	0	0	3	95				
BLC4	12,709	0	0					4	92	13,245	0	0	4	96	13,503	0	0	4	98				
RCCO	12,416	1	0					3	90	12,940	1	0	3	94	13,192	1	0	3	95				
LCCO	12,416	1	0					3	90	12,940	1	0	3	94	13,192	1	0	3	95				
AFR	18,052	2	0					3	131	18,814	2	0	3	136	19,180	2	0	3	139				
P6	165W	40	1250					T1S	21,031	2	0	3	127	21,918	2	0	3	133	22,345	2	0	3	135
								T2M	19,482	3	0	4	118	20,303	3	0	4	123	20,699	3	0	4	125
				T3M	19,708	3	0	5	119	20,539	3	0	5	124	20,939	3	0	5	127				
				T3LG	17,604	2	0	2	107	18,347	2	0	2	111	18,704	2	0	2	113				
				T4M	20,001	3	0	5	121	20,845	3	0	5	126	21,251	3	0	5	129				
				T4LG	18,191	2	0	2	110	18,959	2	0	2	115	19,328	2	0	2	117				
				TFTM	20,140	3	0	5	122	20,989	3	0	5	127	21,398	3	0	5	129				
				T5M	20,579	5	0	3	125	21,447	5	0	3	130	21,865	5	0	3	132				
				T5W	20,912	5	0	3	127	21,795	5	0	3	132	22,219	5	0	3	134				
				T5LG	20,638	4	0	2	125	21,509	4	0	2	130	21,928	4	0	2	133				
				BLC3	14,335	0	0	3	87	14,940	0	0	3	90	15,231	0	0	3	92				
				BLC4	14,805	0	0	4	90	15,430	0	0	4	93	15,731	0	0	4	95				
				RCCO	14,464	1	0	3	88	15,074	1	0	3	91	15,368	1	0	3	93				
				LCCO	14,464	1	0	3	88	15,074	1	0	3	91	15,368	1	0	3	93				
				AFR	21,031	2	0	3	127	21,918	2	0	3	133	22,345	2	0	3	135				

Performance Data

Lumen Output

Lumen values are from photometric tests performed in accordance with IESNA LM-79-08. Data is considered to be representative of configurations shown within the tolerances described within LM-79. Contact factory for performance data on any configurations not shown here.

Forward Optics																			
Performance Package	System Watts	LED Count	Drive Current (mA)	Distribution Type	30K					40K					50K				
					(3000K, 70 CRI)					(4000K, 70 CRI)					(5000K, 70 CRI)				
					Lumens	B	U	G	LPW	Lumens	B	U	G	LPW	Lumens	B	U	G	LPW
P7	184W	40	1400	T1S	22,741	2	0	3	123	23,700	2	0	3	129	24,162	3	0	3	131
				T2M	21,066	3	0	4	114	21,955	3	0	4	119	22,383	3	0	4	121
				T3M	21,311	3	0	5	116	22,210	3	0	5	120	22,642	3	0	5	123
				T3LG	19,036	2	0	2	103	19,839	2	0	3	108	20,226	2	0	3	110
				T4M	21,628	3	0	5	117	22,541	3	0	5	122	22,980	3	0	5	125
				T4LG	19,671	2	0	2	107	20,501	2	0	3	111	20,900	2	0	3	113
				TFTM	21,778	3	0	5	118	22,697	3	0	5	123	23,139	3	0	5	125
				T5M	22,252	5	0	3	121	23,191	5	0	3	126	23,643	5	0	3	128
				T5W	22,613	5	0	3	123	23,567	5	0	4	128	24,027	5	0	4	130
				T5LG	22,317	4	0	2	121	23,258	4	0	2	126	23,712	4	0	2	129
				BLC3	15,501	0	0	3	84	16,155	0	0	4	88	16,470	0	0	4	89
				BLC4	16,010	0	0	4	87	16,685	0	0	4	90	17,010	0	0	4	92
				RCCO	15,641	1	0	3	85	16,301	1	0	3	89	16,619	1	0	3	90
				LCCO	15,641	1	0	3	85	16,301	1	0	3	89	16,619	1	0	3	90
				AFR	22,741	2	0	3	123	23,700	2	0	3	129	24,162	3	0	3	131
				P8	216W	60	1100	T1S	28,701	3	0	3	133	29,912	3	0	4	139	30,495
T2M	26,587	3	0					5	123	27,709	3	0	5	128	28,249	3	0	5	131
T3M	26,895	3	0					5	125	28,030	3	0	5	130	28,576	3	0	5	132
T3LG	24,025	3	0					3	111	25,038	3	0	3	116	25,526	3	0	3	118
T4M	27,296	3	0					5	127	28,448	3	0	5	132	29,002	3	0	5	134
T4LG	24,826	3	0					3	115	25,873	3	0	3	120	26,378	3	0	3	122
TFTM	27,485	3	0					5	127	28,645	3	0	5	133	29,203	3	0	5	135
T5M	28,084	5	0					4	130	29,269	5	0	4	136	29,839	5	0	4	138
T5W	28,539	5	0					4	132	29,743	5	0	4	138	30,323	5	0	4	141
T5LG	28,165	4	0					2	131	29,354	4	0	2	136	29,926	4	0	2	139
BLC3	19,563	0	0					4	91	20,388	0	0	4	94	20,786	0	0	4	96
BLC4	20,205	0	0					5	94	21,057	0	0	5	98	21,468	0	0	5	99
RCCO	19,740	1	0					4	91	20,572	1	0	4	95	20,973	1	0	4	97
LCCO	19,740	1	0					4	91	20,572	1	0	4	95	20,973	1	0	4	97
AFR	28,701	3	0					3	133	29,912	3	0	4	139	30,495	3	0	4	141
P9	277W	60	1400					T1S	34,819	3	0	4	126	36,288	3	0	4	131	36,996
				T2M	32,255	3	0	5	116	33,616	3	0	5	121	34,271	3	0	5	124
				T3M	32,629	3	0	5	118	34,006	3	0	5	123	34,668	3	0	5	125
				T3LG	29,146	3	0	3	105	30,376	3	0	4	110	30,968	3	0	4	112
				T4M	33,116	3	0	5	120	34,513	3	0	5	125	35,185	3	0	5	127
				T4LG	30,119	3	0	3	109	31,389	3	0	4	113	32,001	3	0	4	116
				TFTM	33,345	3	0	5	120	34,751	3	0	5	125	35,429	3	0	5	128
				T5M	34,071	5	0	4	123	35,509	5	0	4	128	36,201	5	0	4	131
				T5W	34,624	5	0	4	125	36,084	5	0	4	130	36,788	5	0	4	133
				T5LG	34,170	5	0	3	123	35,612	5	0	3	129	36,306	5	0	3	131
				BLC3	23,734	0	0	4	86	24,735	0	0	4	89	25,217	0	0	4	91
				BLC4	24,513	0	0	5	88	25,547	0	0	5	92	26,045	0	0	5	94
				RCCO	23,948	1	0	4	86	24,958	1	0	4	90	25,445	1	0	4	92
				LCCO	23,948	1	0	4	86	24,958	1	0	4	90	25,445	1	0	4	92
				AFR	34,819	3	0	4	126	36,288	3	0	4	131	36,996	3	0	4	134

Performance Data

Lumen Output

Lumen values are from photometric tests performed in accordance with IESNA LM-79-08. Data is considered to be representative of configurations shown within the tolerances described within LM-79. Contact factory for performance data on any configurations not shown here.

Rotated Optics																							
Performance Package	System Watts	LED Count	Drive Current (mA)	Distribution Type	30K					40K					50K								
					(3000K, 70 CRI)					(4000K, 70 CRI)					(5000K, 70 CRI)								
					Lumens	B	U	G	LPW	Lumens	B	U	G	LPW	Lumens	B	U	G	LPW				
P10	101W	60	530	T1S	15,164	3	0	3	150	15,803	3	0	3	156	16,112	3	0	3	159				
				T2M	14,047	4	0	4	139	14,640	4	0	4	145	14,925	4	0	4	147				
				T3M	14,208	4	0	4	140	14,807	4	0	4	146	15,096	4	0	4	149				
				T3LG	12,693	3	0	3	125	13,229	3	0	3	131	13,487	3	0	3	133				
				T4M	14,420	4	0	4	142	15,028	4	0	4	148	15,321	4	0	4	151				
				T4LG	13,115	3	0	3	129	13,668	3	0	3	135	13,934	3	0	3	138				
				TFTM	14,522	4	0	4	143	15,134	4	0	4	149	15,429	4	0	4	152				
				T5M	14,836	4	0	2	146	15,462	4	0	2	153	15,763	4	0	2	156				
				T5W	15,076	4	0	3	149	15,712	5	0	3	155	16,019	5	0	3	158				
				T5LG	14,879	3	0	2	147	15,507	3	0	2	153	15,809	3	0	2	156				
				BLC3	10,335	3	0	3	102	10,771	4	0	4	106	10,981	4	0	4	108				
				BLC4	10,674	4	0	4	105	11,124	4	0	4	110	11,341	4	0	4	112				
				RCCO	10,429	1	0	2	103	10,869	1	0	2	107	11,080	1	0	2	109				
				LCCO	10,429	1	0	2	103	10,869	1	0	2	107	11,080	1	0	2	109				
				AFR	15,164	3	0	3	150	15,803	3	0	3	156	16,112	3	0	3	159				
				P11	135W	60	700	T1S	19,437	4	0	4	144	20,257	4	0	4	150	20,651	4	0	4	153
								T2M	18,005	4	0	4	133	18,765	4	0	4	139	19,131	4	0	4	142
T3M	18,211	4	0					4	135	18,980	4	0	4	141	19,350	4	0	4	143				
T3LG	16,270	3	0					3	121	16,957	3	0	3	126	17,287	4	0	4	128				
T4M	18,483	4	0					4	137	19,263	5	0	5	143	19,638	5	0	5	146				
T4LG	16,810	3	0					3	125	17,519	3	0	3	130	17,861	3	0	3	132				
TFTM	18,614	4	0					4	138	19,399	4	0	4	144	19,777	5	0	5	147				
T5M	19,017	5	0					3	141	19,819	5	0	3	147	20,205	5	0	3	150				
T5W	19,325	5	0					3	143	20,140	5	0	3	149	20,533	5	0	3	152				
T5LG	19,072	4	0					2	141	19,876	4	0	2	147	20,264	4	0	2	150				
BLC3	13,247	4	0					4	98	13,806	4	0	4	102	14,075	4	0	4	104				
BLC4	13,682	4	0					4	101	14,259	4	0	4	106	14,537	4	0	4	108				
RCCO	13,367	1	0					3	99	13,931	1	0	3	103	14,203	1	0	3	105				
LCCO	13,367	1	0					3	99	13,931	1	0	3	103	14,203	1	0	3	105				
AFR	19,437	4	0					4	144	20,257	4	0	4	150	20,651	4	0	4	153				
P12	206W	60	1050					T1S	27,457	4	0	4	133	28,616	4	0	4	139	29,174	4	0	4	142
								T2M	25,436	5	0	5	124	26,509	5	0	5	129	27,025	5	0	5	131
				T3M	25,727	5	0	5	125	26,812	5	0	5	130	27,335	5	0	5	133				
				T3LG	22,984	4	0	4	112	23,954	4	0	4	116	24,421	4	0	4	119				
				T4M	26,110	5	0	5	127	27,212	5	0	5	132	27,742	5	0	5	135				
				T4LG	23,747	4	0	4	115	24,749	4	0	4	120	25,231	4	0	4	123				
				TFTM	26,295	5	0	5	128	27,404	5	0	5	133	27,938	5	0	5	136				
				T5M	26,864	5	0	4	130	27,997	5	0	4	136	28,543	5	0	4	139				
				T5W	27,299	5	0	4	133	28,451	5	0	4	138	29,006	5	0	4	141				
				T5LG	26,942	4	0	2	131	28,078	4	0	2	136	28,626	4	0	2	139				
				BLC3	18,714	4	0	4	91	19,504	4	0	4	95	19,884	4	0	4	97				
				BLC4	19,327	5	0	5	94	20,143	5	0	5	98	20,535	5	0	5	100				
				RCCO	18,883	1	0	4	92	19,680	1	0	4	96	20,064	1	0	4	97				
				LCCO	18,883	1	0	4	92	19,680	1	0	4	96	20,064	1	0	4	97				
				AFR	27,457	4	0	4	133	28,616	4	0	4	139	29,174	4	0	4	142				
				P13	276W	60	1400	T1S	34,436	5	0	5	125	35,889	5	0	5	130	36,588	5	0	5	133
								T2M	31,900	5	0	5	116	33,246	5	0	5	121	33,894	5	0	5	123
T3M	32,265	5	0					5	117	33,626	5	0	5	122	34,282	5	0	5	124				
T3LG	28,826	4	0					4	105	30,042	4	0	4	109	30,628	4	0	4	111				
T4M	32,746	5	0					5	119	34,128	5	0	5	124	34,793	5	0	5	126				
T4LG	29,782	4	0					4	108	31,039	4	0	4	113	31,644	5	0	4	115				
TFTM	32,978	5	0					5	120	34,369	5	0	5	125	35,039	5	0	5	127				
T5M	33,692	5	0					4	122	35,113	5	0	4	127	35,797	5	0	4	130				
T5W	34,238	5	0					4	124	35,682	5	0	4	129	36,378	5	0	4	132				
T5LG	33,789	5	0					3	122	35,215	5	0	3	128	35,901	5	0	3	130				
BLC3	23,471	5	0					5	85	24,461	5	0	5	89	24,937	5	0	5	90				
BLC4	24,240	5	0					5	88	25,262	5	0	5	92	25,755	5	0	5	93				
RCCO	23,683	1	0					4	86	24,682	1	0	4	89	25,163	1	0	4	91				
LCCO	23,683	1	0					4	86	24,682	1	0	4	89	25,163	1	0	4	91				
AFR	34,436	5	0					5	125	35,889	5	0	5	130	36,588	5	0	5	133				

Dimensions

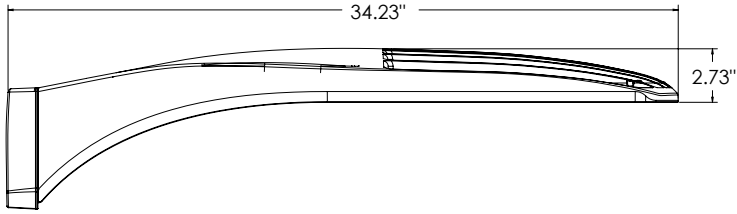

DSX1 with RPA, RPA5, SPA5, SPA8N mount
Weight: 36 lbs

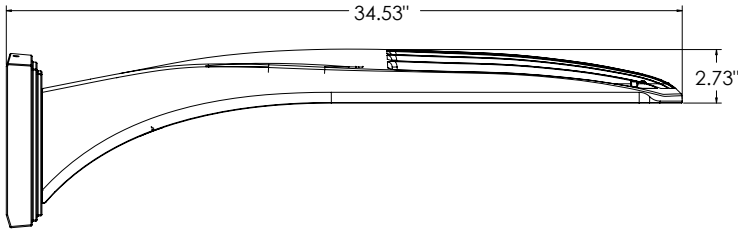
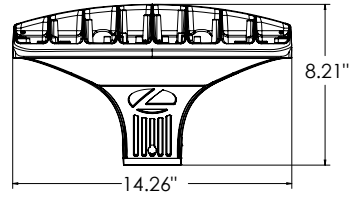

DSX1 with WBA mount
Weight: 38 lbs

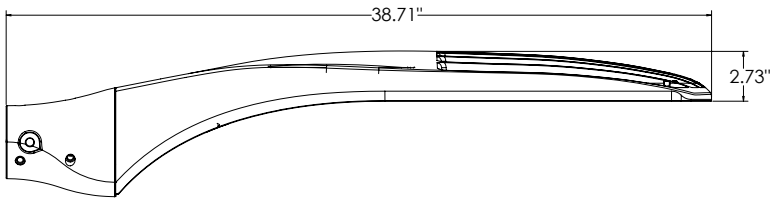
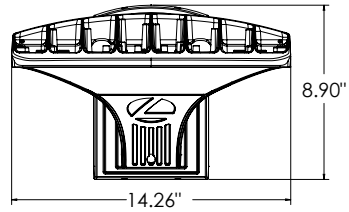

DSX1 with MA mount
Weight: 39 lbs

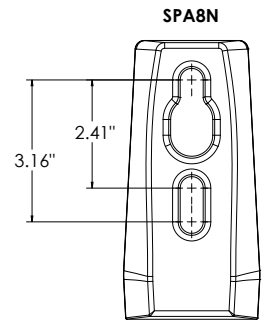
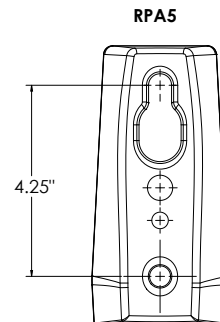
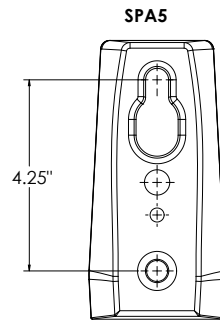
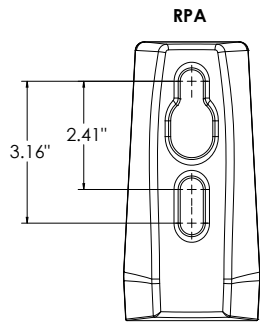
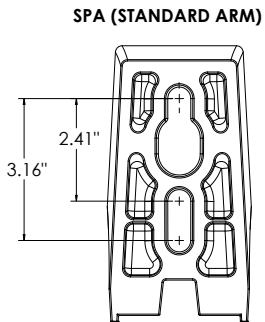
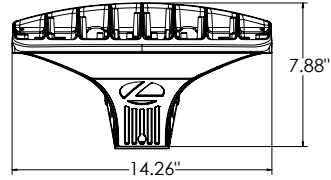

nLight Sensor Coverage Pattern

NLTAIR2 PIRHN

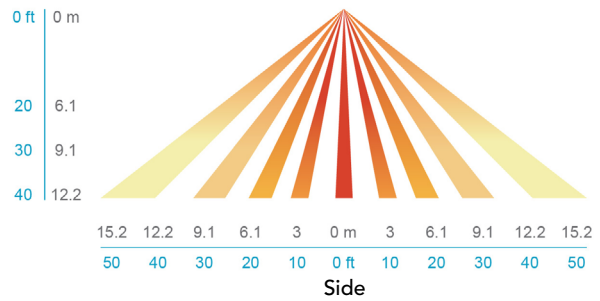
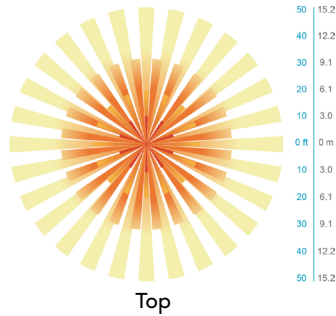

FEATURES & SPECIFICATIONS

INTENDED USE

The sleek design of the D-Series Size 1 reflects the embedded high performance LED technology. It is ideal for many commercial and municipal applications, such as parking lots, plazas, campuses, and streetscapes.

CONSTRUCTION

Single-piece die-cast aluminum housing has integral heat sink fins to optimize thermal management through conductive and convective cooling. Modular design allows for ease of maintenance and future light engine upgrades. The LED drivers are mounted in direct contact with the casting to promote low operating temperature and long life. Housing driver compartment is completely sealed against moisture and environmental contaminants (IP66). Vibration rated per ANSI C136.31 for 3G for SPA and MA. 1.5G for mountings RPA, RPA5, SPA5 and SPA8N. Low EPA (0.69 ft²) for optimized pole wind loading.

FINISH

Exterior parts are protected by a zinc-infused Super Durable TGIC thermoset powder coat finish that provides superior resistance to corrosion and weathering. A tightly controlled multi-stage process ensures a minimum 3 mils thickness for a finish that can withstand extreme climate changes without cracking or peeling. Available in both textured and non-textured finishes.

Coastal Construction (CCE)

Optional corrosion resistant construction is engineered with added corrosion protection in materials and/or pre-treatment of base material under super durable paint. Provides additional corrosion protection for applications near coastal areas. Finish is salt spray tested to over 5,000 hours per ASTM B117 with scribe rating of 10. Additional lead-times may apply.

OPTICS

Precision-molded proprietary silicone lenses are engineered for superior area lighting distribution, uniformity, and pole spacing. Light engines are available in standard 3000 K, 4000 K and 5000 K (70 CRI) configurations. 80CRI configurations are also available. The D-Series Size 1 has zero uplight and qualifies as a Nighttime Friendly™ product, meaning it is consistent with the LEED® and Green Globes™ criteria for eliminating wasteful uplight.

ELECTRICAL

Light engine configurations consist of high-efficacy LEDs mounted to metal-core circuit boards to maximize heat dissipation and promote long life (up to L81/100,000 hours at 25°C). Class 1 electronic drivers are designed to have a power factor >90%, THD <20%, and an expected life of 100,000 hours with <1% failure rate. Easily serviceable 10kV surge protection device meets a minimum Category C Low operation (per ANSI/IEEE C62.41.2).

STANDARD CONTROLS

The DSX1 LED area luminaire has a number of control options. DSX Size 1, comes standard with 0-10V dimming drivers. Dusk to dawn controls can be utilized via optional NEMA twist-lock photocell receptacles. Integrated motion sensor with on-board photocells feature field-adjustable programming and are suitable for mounting heights up to 40 feet. Control option BL features a bi-level device that allows a second control circuit to switch all light engines to either 30% or 50% light output.

nLIGHT AIR CONTROLS

The DSX1 LED area luminaire is also available with nLight® AIR for the ultimate in wireless control. This powerful controls platform provides out-of-the-box basic motion sensing and photocontrol functionality and is suitable for mounting heights up to 40 feet. Once commissioned using a smartphone and the easy-to-use CLAIRITY app, nLight AIR equipped luminaires can be grouped, resulting in motion sensor and photocell group response without the need for additional equipment. Scheduled dimming with motion sensor over-ride can be achieved when used with the nLight Eclipse. Additional information about nLight Air can be found here.

INSTALLATION

Integral mounting arm allows for fast mounting using Lithonia standard #8 drilling and accommodates pole drilling's from 2.41 to 3.12" on center. The standard "SPA" option for square poles and the "RPA" option for round poles use the #8 drilling. For #5 pole drillings, use SPA5 or RPA5. Additional mountings are available including a wall bracket (WBA) and mast arm (MA) option that allows luminaire attachment to a 2 3/8" horizontal mast arm.

LISTINGS

UL listed to meet U.S. and Canadian standards. UL Listed for wet locations. Light engines are IP66 rated; luminaire is IP66 rated. Rated for -40°C minimum ambient.

DesignLights Consortium® (DLC) Premium qualified product and DLC qualified product. Not all versions of this product may be DLC Premium qualified or DLC qualified. Please check the DLC Qualified Products List at www.designlights.org/QPL to confirm which versions are qualified.

International Dark-Sky Association (IDA) Fixture Seal of Approval (FSA) is available for all products on this page utilizing 3000K color temperature only.

BUY AMERICAN ACT

Product with the BAA option is assembled in the USA and meets the Buy America(n) government procurement requirements under FAR, DFARS and DOT regulations. Please refer to www.acuitybrands.com/buy-american for additional information.

WARRANTY

5-year limited warranty. This is the only warranty provided and no other statements in this specification sheet create any warranty of any kind. All other express and implied warranties are disclaimed. Complete warranty terms located at: www.acuitybrands.com/support/warranty/terms-and-conditions

Note: Actual performance may differ as a result of end-user environment and application. All values are design or typical values, measured under laboratory conditions at 25 °C. Specifications subject to change without notice.



RSX2 LED Area Luminaire



Catalog Number
Notes
Type

Hit the Tab key or mouse over the page to see all interactive elements.

Specifications

EPA (ft ² @0°):	0.69 ft ² (0.06 m ²)
Length:	29.3" (74.4 cm) (SPA mount)
Width:	13.4" (34.0 cm)
Height:	3.0" (7.6 cm) Main Body 7.2" (18.3 cm) Arm
Weight: (SPA mount)	30.0 lbs (13.6 kg)

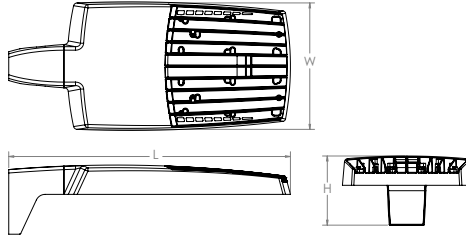

Introduction

The new RSX LED Area family delivers maximum value by providing significant energy savings, long life and outstanding photometric performance at an affordable price. The RSX2 delivers 11,000 to 31,000 lumens allowing it to replace 250W to 1000W HID luminaires.

The RSX features an integral universal mounting mechanism that allows the luminaire to be mounted on most existing drill hole patterns. This "no-drill" solution provides significant labor savings. An easy-access door on the bottom of mounting arm allows for wiring without opening the electrical compartment. A mast arm adaptor, adjustable integral slipfitter and other mounting configurations are available.



Items marked by a shaded background qualify for the Design Select program and ship in 15 days or less. To learn more about Design Select, visit www.acuitybrands.com/designselect.
*See ordering tree for details

Ordering Information

EXAMPLE: RSX2 LED P6 40K R3 MVOLT SPA DDBXD

Series	Performance Package	Color Temperature	Distribution	Voltage	Mounting
RSX2 LED	P1 P2 P3 P4 P5 P6	30K 3000K 40K 4000K 50K 5000K	R2 Type 2 Wide R3 Type 3 Wide R3S Type 3 Short R4 Type 4 Wide R4S Type 4 Short R5 Type 5 Wide ¹ R5S Type 5 Short ¹ AFR Automotive Front Row AFRR90 Automotive Front Row Right Rotated AFRL90 Automotive Front Row Left Rotated	MVOLT (120V-277V) ² HVOLT (347V-480V) ³ XVOLT (277V-480V) ⁴ (use specific voltage for options as noted) 120 ³ 277 ⁵ 208 ³ 347 ⁵ 240 ³ 480 ⁵	SPA Square pole mounting (3.0" min. SQ pole for 1 at 90°, 3.5" min. SQ pole for 2, 3, 4 at 90°) RPA Round pole mounting (3.2" min. dia. RND pole for 2, 3, 4 at 90°, 3.0" min. dia. RND pole for 1 at 90°, 2 at 180°, 3 at 120°) MA Mast arm adaptor (fits 2-3/8" OD horizontal tenon) IS Adjustable slipfitter (fits 2-3/8" OD tenon) ⁶ WBA Wall bracket ¹ WBASC Wall bracket with surface conduit box AASP Adjustable tilt arm square pole mounting ⁶ AARP Adjustable tilt arm round pole mounting ⁶ AAWB Adjustable tilt arm with wall bracket ⁶ AAWSC Adjustable tilt arm wall bracket and surface conduit box ⁶

Options	Finish
<p>Shipped Installed</p> <p>HS House-side shield⁷</p> <p>PE Photocontrol, button style^{8,9}</p> <p>PER7 Seven-wire twist-lock receptacle only (no controls)^{9,10,11}</p> <p>SF Single fuse (120, 277, 347)⁵</p> <p>DF Double fuse (208, 240, 480)⁵</p> <p>SPD20KV 20KV Surge pack (10KV standard)</p> <p>FAO Field adjustable output⁹</p> <p>DMG 0-10V dimming extend out back of housing for external control (control ordered separate)⁹</p> <p>DS Dual switching^{9,12}</p>	<p>DDBXD Dark Bronze</p> <p>DBLXD Black</p> <p>DNAXD Natural Aluminum</p> <p>DWHXD White</p> <p>DDBTXD Textured Dark Bronze</p> <p>DBLTXD Textured Black</p> <p>DNATXD Textured Natural Aluminum</p> <p>DWHGXD Textured White</p>
<p>Shipped Installed</p> <p>*Standalone and Networked Sensors/Controls (factory default settings, see table page 9)</p> <p>NLTAIR2 PIRHN nLight AIR generation 2, with Networked, Bi-Level motion/ambient sensor^{9,13,14,15}</p> <p>BAA Buy America(n) Act Compliant</p> <p>CCE Coastal Construction¹⁶</p> <p>*Note: NLTAIR2 PIRHN with nLight Air can be used as a standalone dimming sensor with out-of-box settings or as a wireless networked solution. See factory default settings table. Sensor coverage pattern is affected when luminaire is tilted.</p> <p>Shipped Separately (requires some field assembly)</p> <p>EGS External glare shield⁷</p> <p>EGFV External glare full visor (360° around light aperture)⁷</p> <p>BS Bird spikes¹⁷</p>	



Ordering Information

Accessories

Ordered and shipped separately.

RSX2HS	RSX2 House side shield (includes 2 shields)
RSX2EGS (FINISH) U	External glare shield (specify finish)
RSX2HSFRR (FINISH) U	RSX2 House side shields for AFR rotated optics (includes 2 shields)
RSX2EGFV (FINISH) U	External glare full visor (specify finish)
RSXRPA (FINISH) U	RSX Universal round pole adaptor plate (specify finish)
RSXWBA (FINISH) U	RSX WBA wall bracket (specify finish) ¹
RSXSBC (FINISH) U	RSX Surface conduit box (specify finish, for use with WBA, WBA not included)
DLL127F 1.5 JU	Photocell -SSL twist-lock (120-277V) ¹⁸
DLL347F 1.5 CULJU	Photocell -SSL twist-lock (347V) ¹⁸
DLL480F 1.5 CULJU	Photocell -SSL twist-lock (480V) ¹⁸
DSHORT SBK U	Shorting cap ¹⁸

NOTES

- 1 Any Type 5 distribution, is not available with WBA.
- 2 MVOLT driver operates on any line voltage from 120-277V (50/60 Hz).
- 3 HVOLT driver operates on any line voltage from 347-480V (50/60 Hz).
- 4 XVOLT driver not available with P1. XVOLT driver operates on any line voltage from 277V-480V (50/60 Hz). XVOLT not available with fusing (SF or DF) and not available with PE.
- 5 Single fuse (SF) requires 120V, 277V or 347V. Double fuse (DF) requires 208V, 240V or 480V.
- 6 Maximum tilt is 90° above horizontal.
- 7 It may be ordered as an accessory.
- 8 Requires MVOLT or 347V.
- 9 Two or more of the following options cannot be combined including PE, DMG, PER7, FAO, DS and NLTAIR2 PIRHN. (Exception: PE and FAO can be combined; also PE and DMG can be combined.)
- 10 Compatible with standard twist-lock photocells for dusk to dawn operation or advanced control nodes that provide 0-10V dimming signals. Wire 4/Wire 5 wired to dimming leads on driver. Wire 6/Wire 7 capped inside luminaire. Twistlock photocell ordered and shipped

- as a separate line item from Acuity Brands Controls. See accessories. Shorting Cap included.
- 11 For units with option PER7, the mounting must be restricted to +/- 45° from horizontal aim per ANSI C136.10-2010.
 - 12 DS requires (2) separately switched circuits. DS provides 50/50 fixture operation via (2) different sets of leads using (2) drivers. DS only available with packages P5 and P6.
 - 13 Must be ordered with PIRHN.
 - 14 Requires MVOLT or HVOLT.
 - 15 Must be ordered with NLTAIR2. For additional information on PIRHN visit [here](#).
 - 16 CCE option not available with WBA, WBASC, AASP, AARP, AAWB, AAWBSC, EGS, EGFV and BS.
 - 17 Must be ordered with fixture for factory pre-drilling.
 - 18 Requires luminaire to be specified with PER7 option. Ordered and shipped as a separate line item from Acuity Brands Controls.

External Shields

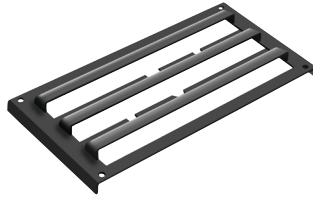

House Side Shield



External Glare Shield



External 360 Full Visor

Pole/Mounting Information

Accessories including bullhorns, cross arms and other adapters are available under the accessories tab at Lithonia's Outdoor Poles and Arms product page. Click here to visit [Accessories](#).

HANDHOLE ORIENTATION

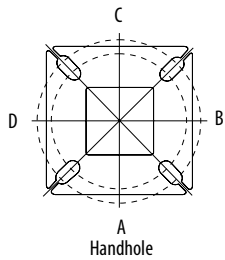

RSX POLE DRILLING

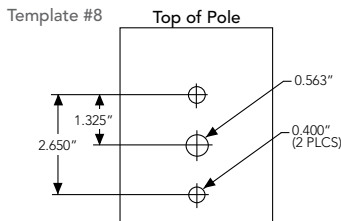

RSX STANDARD ARM & ADJUSTABLE ARM

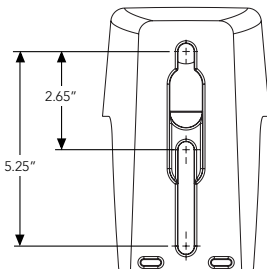

Round Tenon Mount - Pole Top Slipfitters

Tenon O.D.	RSX Mounting	Single	2 at 180°	2 at 90°	3 at 120°	3 at 90°	4 at 90°
2 - 3/8"	RPA, AARP	AS3-5 190	AS3-5 280	AS3-5 290	AS3-5 320	AS3-5 390	AS3-5 490
2 - 7/8"	RPA, AARP	AST25-190	AST25-280	AST25-290	AST25-320	AST25-390	AST25-490
4"	RPA, AARP	AST35-190	AST35-280	AST35-290	AST35-320	AST35-390	AST35-490

Drill/Side Location by Configuration Type

Drilling Template	Mounting Option	Single	2 @ 180	2 @ 90	3 @ 120	3 @ 90	4 @ 90
	Head Location	Side B	Side B & D	Side B & C	Round Pole Only	Side B, C & D	Side A, B, C & D
#8	Drill Nomenclature	DM19AS	DM28AS	DM29AS	DM32AS	DM39AS	DM49AS

RSX2 - Luminaire EPA

*Includes luminaire and integral mounting arm. Other tenons, arms, brackets or other accessories are not included in this EPA data.

Fixture Quantity & Mounting Configuration	Single	2 @ 90	2 @ 180	3 @ 90	3 @ 120	4 @ 90	2 Side by Side	3 Side by Side	4 Side by Side	
SPA - Square Pole Adaptor	0.69	1.22	1.27	1.8	1.61	2.39	1.37	2.06	2.74	
RPA - Round Pole Adaptor	0.74	1.27	1.37	1.9	1.71	2.49	1.42	2.16	2.84	
MA - Mast Arm Adaptor	0.61	1.14	1.11	1.64	1.45	2.23	1.29	1.9	2.58	
IS - Integral Slipfitter AASP/AARP - Adjustable Arm Square/Round Pole	0°	0.69	1.22	1.27	1.8	1.61	2.39	1.37	2.06	2.74
	10°	0.53	1.06	1.05	1.58	1.37	2.08	1.06	1.59	2.12
	20°	0.52	1.02	1.03	1.52	1.33	2.02	1.03	1.55	2.07
	30°	0.64	1.11	1.18	1.63	1.45	2.21	1.27	1.91	2.54
	40°	0.81	1.21	1.35	1.74	1.65	2.39	1.62	2.43	3.23
	45°	0.91	1.25	1.5	1.81	1.75	2.48	1.82	2.73	3.64
	50°	1.34	1.83	2.17	2.61	2.56	3.62	2.68	4.02	5.36
	60°	2.2	2.97	3.57	4.24	4.17	5.89	4.41	6.61	8.82
	70°	2.86	4.13	4.7	5.89	5.71	8.21	5.71	8.57	11.42
	80°	3.4	5.13	5.67	7.34	7.09	10.21	6.79	10.19	13.59
	90°	3.85	5.96	6.55	8.58	8.31	11.88	7.70	11.56	15.41

Photometric Diagrams

To see complete photometric reports or download .ies files for this product, visit Lithonia Lighting's RSX Area homepage.

Isofootcandle plots for the RSX2 LED P6 40K. Distances are in units of mounting height (30').

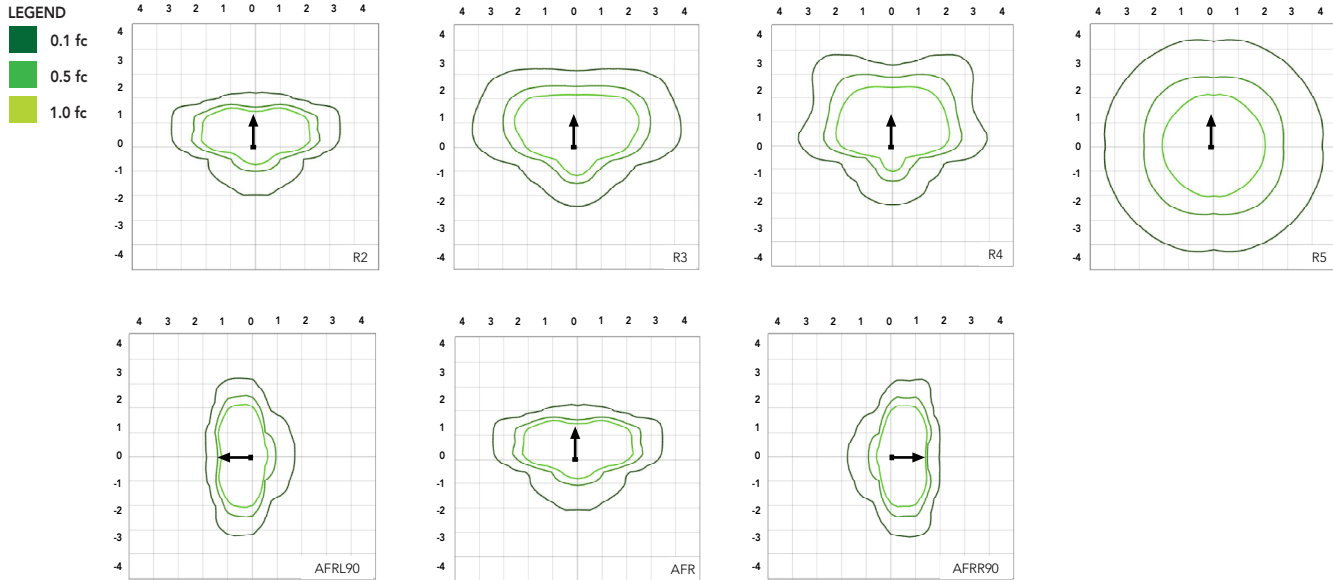

Performance Data

Lumen Ambient Temperature (LAT) Multipliers

Use these factors to determine relative lumen output for average ambient temperatures from 0-50°C (32-122°F).

Ambient	Ambient	Lumen Multiplier
0°C	32°F	1.05
5°C	41°F	1.04
10°C	50°F	1.03
15°C	59°F	1.02
20°C	68°F	1.01
25°C	77°F	1.00
30°C	86°F	0.99
35°C	95°F	0.98
40°C	104°F	0.97
45°C	113°F	0.96
50°C	122°F	0.95

Electrical Load

Performance Package	System Watts (W)	Current (A)					
		120V	208V	240V	277V	347V	480V
P1	71W	0.59	0.34	0.30	0.26	0.20	0.15
P2	111W	0.93	0.53	0.46	0.40	0.32	0.23
P3	147W	1.23	0.70	0.61	0.53	0.42	0.31
P4	187W	1.55	0.90	0.78	0.68	0.53	0.38
P5	210W	1.75	1.01	0.87	0.76	0.60	0.44
P6	244W	2.03	1.17	1.01	0.88	0.70	0.51

Projected LED Lumen Maintenance

Operating Hours	50,000	75,000	100,000
Lumen Maintenance Factor	>0.97	>0.95	>0.92

Values calculated according to IESNA TM-21-11 methodology and valid up to 40°C.

Lumen Output

Lumen values are from photometric tests performed in accordance with IESNA LM-79-08. Data is considered to be representative of the configurations shown, within the tolerances allowed by Lighting Facts. Contact factory for performance data on any configurations not shown here.

Performance Package	System Watts	Distribution Type	30K (3000K, 70 CRI)					40K (4000K, 70 CRI)					50K (5000K, 70 CRI)				
			Lumens	B	U	G	LPW	Lumens	B	U	G	LPW	Lumens	B	U	G	LPW
P1	71W	R2	10,040	2	0	1	139	11,031	2	0	1	153	11,031	2	0	1	153
		R3	10,005	2	0	2	141	10,992	2	0	2	155	10,992	2	0	2	155
		R3S	10,271	2	0	2	143	11,285	2	0	2	157	11,285	2	0	2	157
		R4	10,136	2	0	2	143	11,136	2	0	2	157	11,136	2	0	2	157
		R4S	9,779	2	0	2	138	10,744	2	0	2	151	10,744	2	0	2	151
		R5	10,271	4	0	2	145	11,285	4	0	2	159	11,285	4	0	2	159
		R5S	10,544	3	0	1	149	11,585	3	0	2	163	11,585	3	0	2	163
		AFR	10,026	2	0	1	141	11,016	2	0	1	155	11,016	2	0	1	155
		AFRR90	10,122	3	0	2	140	11,121	3	0	2	154	11,121	3	0	2	154
		AFRL90	10,164	3	0	2	141	11,167	3	0	2	155	11,167	3	0	2	155
P2	111W	R2	15,712	2	0	2	138	17,263	2	0	2	151	17,263	2	0	2	151
		R3	15,657	2	0	3	141	17,202	3	0	3	155	17,202	3	0	3	155
		R3S	16,075	2	0	2	141	17,661	2	0	2	155	17,661	2	0	2	155
		R4	15,862	2	0	3	143	17,427	2	0	3	157	17,427	2	0	3	157
		R4S	15,304	2	0	2	138	16,815	2	0	2	151	16,815	2	0	2	151
		R5	16,075	4	0	2	145	17,661	5	0	3	159	17,661	5	0	3	159
		R5S	16,502	4	0	2	149	18,130	4	0	2	163	18,130	4	0	2	163
		AFR	15,691	2	0	2	141	17,240	2	0	2	155	17,240	2	0	2	155
		AFRR90	15,841	3	0	3	139	17,404	4	0	3	153	17,404	4	0	3	153
		AFRL90	15,907	3	0	3	139	17,477	4	0	3	153	17,477	4	0	3	153
P3	147W	R2	19,855	3	0	2	132	21,814	3	0	2	145	21,814	3	0	2	145
		R3	19,785	3	0	3	135	21,737	3	0	4	148	21,737	3	0	4	148
		R3S	20,312	3	0	3	135	22,317	3	0	3	149	22,317	3	0	3	149
		R4	20,044	3	0	3	136	22,022	3	0	4	150	22,022	3	0	4	150
		R4S	19,339	3	0	3	132	21,247	3	0	3	145	21,247	3	0	3	145
		R5	20,313	5	0	3	138	22,317	5	0	3	152	22,317	5	0	3	152
		R5S	20,852	4	0	2	142	22,910	4	0	2	156	22,910	4	0	2	156
		AFR	19,828	3	0	2	135	21,785	3	0	2	148	21,785	3	0	2	148
		AFRR90	20,017	4	0	3	133	21,992	4	0	3	147	21,992	4	0	3	147
		AFRL90	20,101	4	0	3	134	22,084	4	0	3	147	22,084	4	0	3	147
P4	187W	R2	22,836	3	0	2	120	25,090	3	0	2	132	25,090	3	0	2	132
		R3	22,756	3	0	4	122	25,002	3	0	4	134	25,002	3	0	4	134
		R3S	23,363	3	0	3	123	25,668	3	0	3	135	25,668	3	0	3	135
		R4	23,054	3	0	4	123	25,329	3	0	4	135	25,329	3	0	4	135
		R4S	22,243	3	0	3	119	25,059	3	0	3	134	25,059	3	0	3	134
		R5	23,363	5	0	3	125	25,669	5	0	4	137	25,669	5	0	4	137
		R5S	23,983	4	0	2	128	26,350	4	0	2	141	26,350	4	0	2	141
		AFR	22,806	3	0	2	122	25,056	3	0	2	134	25,056	3	0	2	134
		AFRR90	23,023	4	0	3	121	25,295	4	0	3	133	25,295	4	0	3	133
		AFRL90	23,120	4	0	3	122	25,401	4	0	3	134	25,401	4	0	3	134
P5	210W	R2	26,141	3	0	2	122	28,721	3	0	2	135	28,721	3	0	2	135
		R3	26,049	3	0	4	124	28,620	3	0	4	136	28,620	3	0	4	136
		R3S	26,744	3	0	3	125	29,383	3	0	4	138	29,383	3	0	4	138
		R4	26,390	3	0	4	126	28,994	3	0	4	138	28,994	3	0	4	138
		R4S	25,462	3	0	3	121	27,974	3	0	3	133	27,974	3	0	3	133
		R5	26,744	5	0	4	127	29,383	5	0	4	140	29,383	5	0	4	140
		R5S	27,454	4	0	2	131	30,163	4	0	2	144	30,163	4	0	2	144
		AFR	26,106	3	0	2	124	28,682	3	0	2	137	28,682	3	0	2	137
		AFRR90	26,354	4	0	3	123	28,955	5	0	3	136	28,955	5	0	3	136
		AFRL90	26,465	4	0	3	124	29,077	5	0	3	136	29,077	5	0	3	136
P6	244W	R2	27,646	3	0	2	112	30,374	3	0	2	123	30,374	3	0	2	123
		R3	27,549	3	0	4	113	30,267	3	0	4	124	30,267	3	0	4	124
		R3S	28,283	3	0	3	115	31,075	3	0	4	126	31,075	3	0	4	126
		R4	27,909	3	0	4	114	30,663	3	0	4	126	30,663	3	0	4	126
		R4S	26,928	3	0	3	110	29,585	3	0	3	121	29,585	3	0	3	121
		R5	28,284	5	0	4	116	31,075	5	0	4	127	31,075	5	0	4	127
		R5S	29,035	4	0	2	119	31,900	5	0	3	131	31,900	5	0	3	131
		AFR	27,608	3	0	2	112	30,332	3	0	2	123	30,332	3	0	2	123
		AFRR90	27,872	4	0	3	113	30,622	5	0	3	124	30,622	5	0	3	124
		AFRL90	27,989	4	0	3	113	30,751	5	0	3	125	30,751	5	0	3	125

Dimensions & Weights

Luminaire Weight by Mounting Type

Mounting Configuration	Total Luminaire Weight
SPA	30 lbs
RPA	32 lbs
MA	30 lbs
WBA	33 lbs
WBASC	36 lbs
IS	33 lbs
AASP	33 lbs
AARP	35 lbs
AAWB	36 lbs
AAWSC	39 lbs

RSX2 with Round Pole Adapter (RPA)

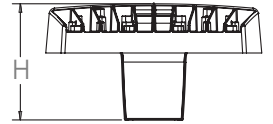
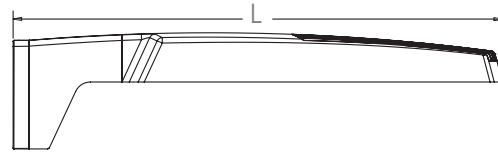
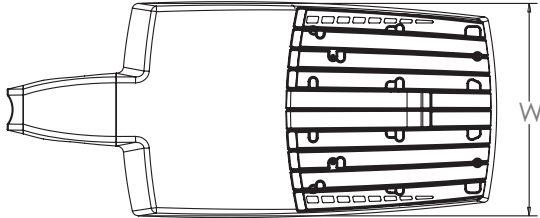

Length: 30.3" (77.0 cm)
 Width: 13.4" (34.0 cm)
 Height: 3.0" (7.6 cm) Main Body
 7.2" (18.3 cm) Arm

Note: RPA — Round Pole mount can also be used to mount on square poles by omitting the round pole adapter plate shown here.



RSX2 with Mast Arm Adapter (MA)

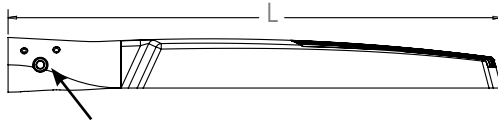
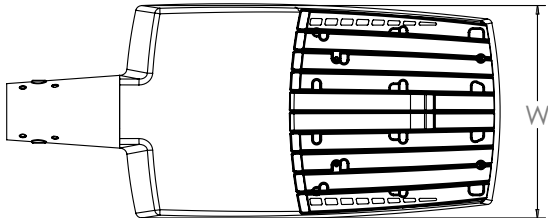

Length: 30.6" (77.7 cm)
 Width: 13.4" (34.0 cm)
 Height: 3.0" (7.6 cm) Main Body
 3.5" (8.9 cm) Arm

7/16" locking thru bolt/nut provided

RSX2 with Adjustable Slipfitter (IS)

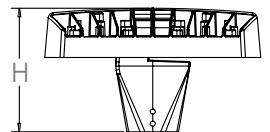
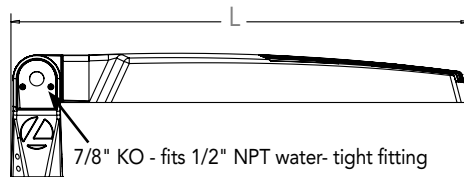
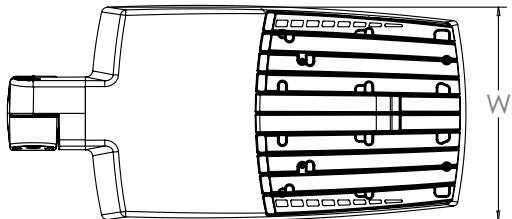

Length: 28.3" (71.9 cm)
 Width: 13.4" (34.0 cm)
 Height: 3.0" (7.6 cm) Main Body
 7.6" (19.3 cm) Arm

7/8" KO - fits 1/2" NPT water-tight fitting

Dimensions

RSX2 with Wall Bracket (WBA)

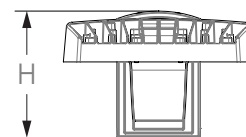
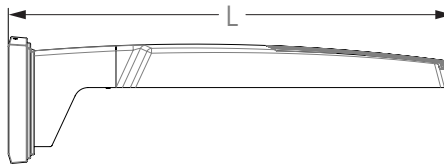
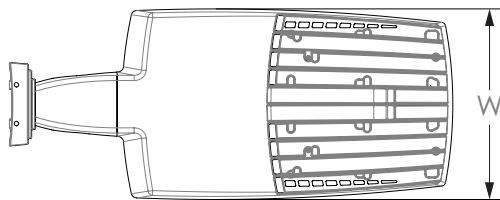

Length: 31.2" (79.2 cm)
 Width: 13.4" (41.7 cm)
 Height: 3.0" (7.6 cm) Main Body
 8.9" (22.6 cm) Arm

Wall Bracket (WBA) Mounting Detail

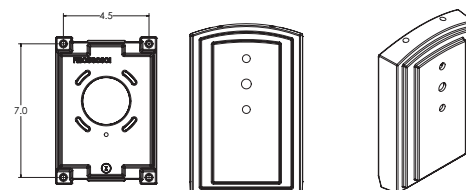

RSX2 with Wall Bracket with Surface Conduit Box (WBASC)

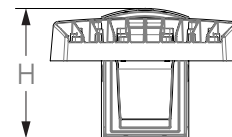
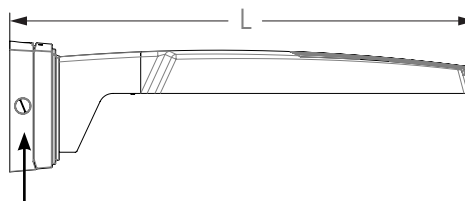
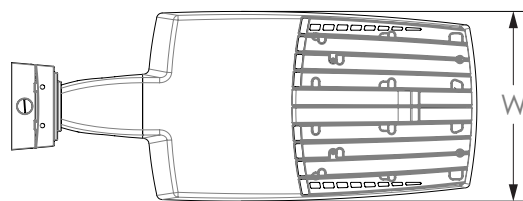

3/4" NPT taps with plugs - Qty (4) provided

Length: 32.8" (83.3 cm)
 Width: 13.4" (41.7 cm)
 Height: 3.0" (7.6 cm) Main Body
 9.2" (23.4 cm) Arm

Surface Conduit Box (SCB) Mounting Detail

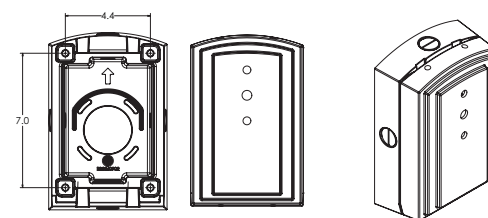

Dimensions

RSX2 with Adjustable Tilt Arm - Square or Round Pole (AASP or AARP)

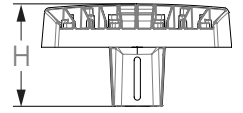
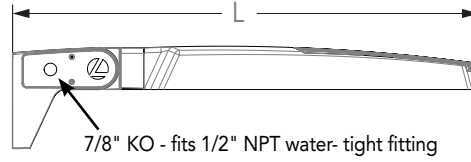
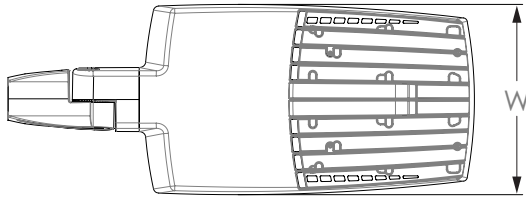

Length: 32.8" (83.3 cm) **AASP**
 33.8" (85.9 cm) **AARP**
 Width: 13.4" (34.0 cm)
 Height: 3.0" (7.6 cm) Main Body
 7.2" (18.2 cm) Arm

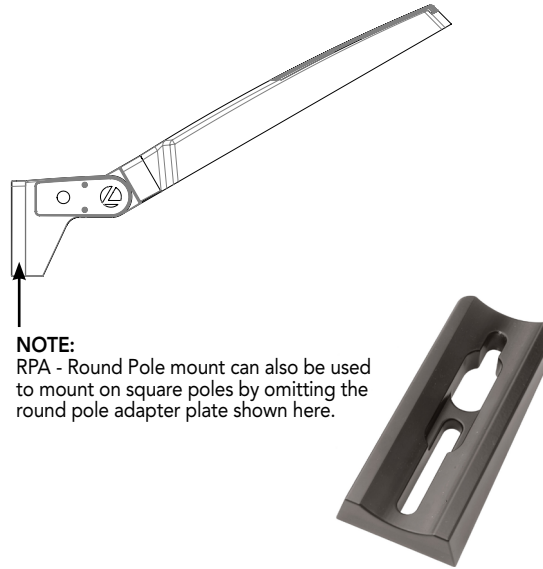

NOTE:
 RPA - Round Pole mount can also be used to mount on square poles by omitting the round pole adapter plate shown here.

Notes

AASP: Requires 3.0" min. square pole for 1 at 90°. Requires 3.5" min. square pole for mounting 2, 3, 4 at 90°.

AARP: Requires 3.2" min. dia. round pole for 2, 3, 4 at 90°. Requires 3.0" min. dia. round pole for mounting 1 at 90°, 2 at 180°, 3 at 120°.

RSX2 with Adjustable Tilt Arm with Wall Bracket (AAWB)

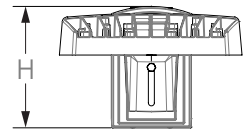
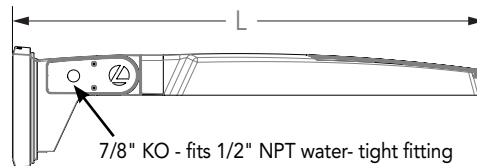
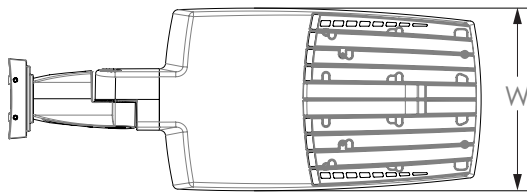

Length: 34.7" (88.0 cm)
 Width: 13.4" (34.0 cm)
 Height: 3.0" (7.6 cm) Main Body
 8.9" (22.6 cm) Arm

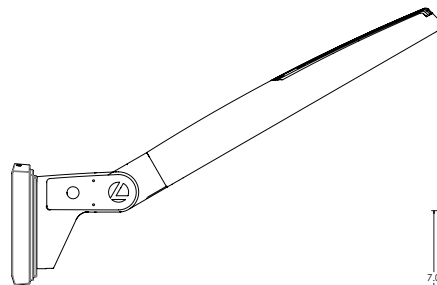

Wall Bracket (WBA) Mounting Detail

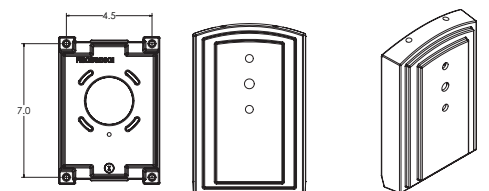

Dimensions

RSX2 with Adjustable Tilt Arm with Wall Bracket and Surface Conduit Box (AAWSC)

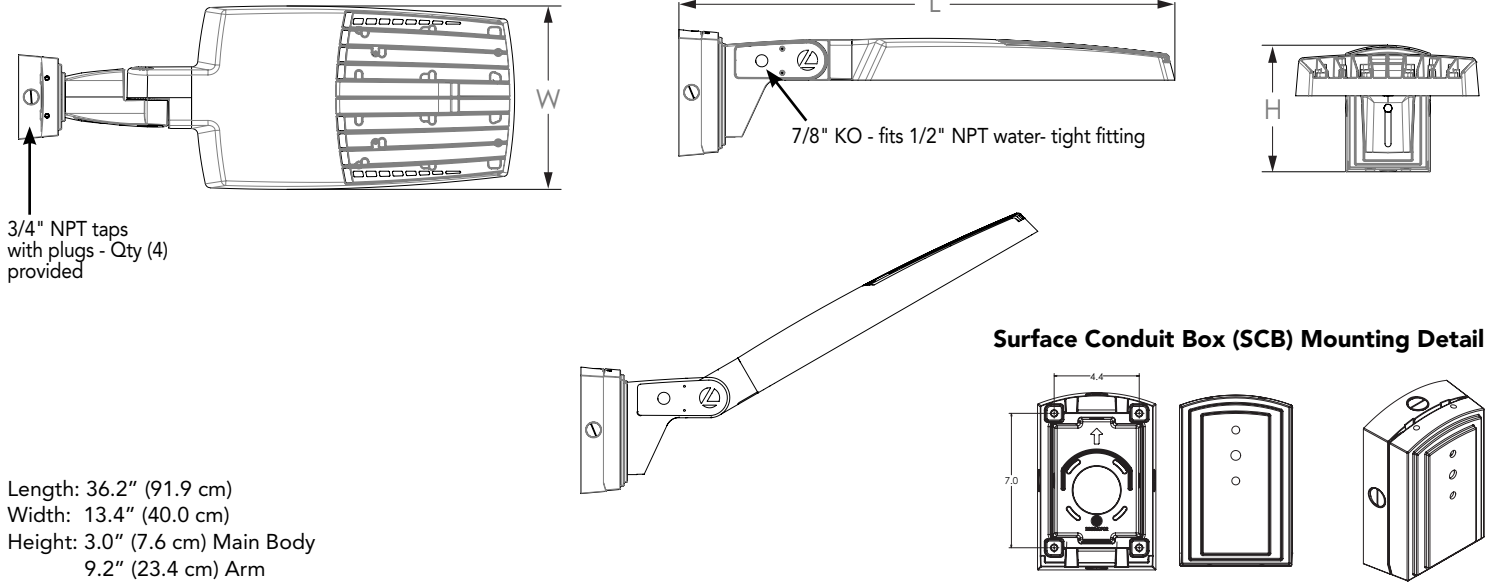

Automotive Front Row - Rotated Optics (AFRL90/R90)

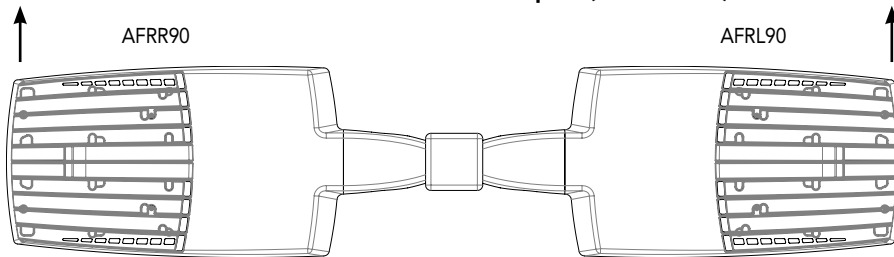

(Example: 2@180 - arrows indicate direction of light exiting the luminaire)

nLight Control - Sensor Coverage and Settings

NLTAIR2 PIRHN nLight Sensor Coverage Pattern nLight PIRHN

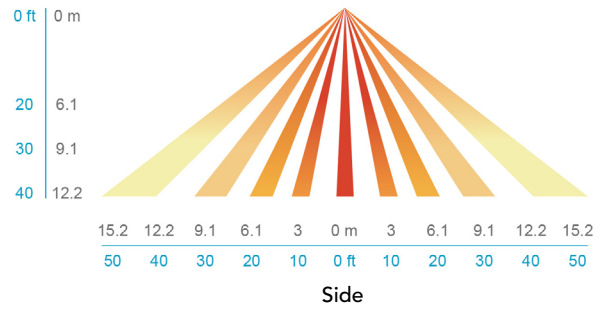
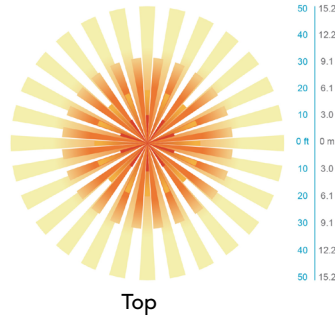
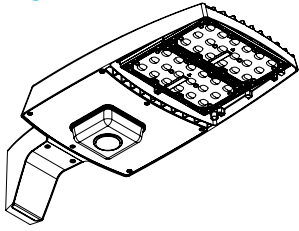

Motion Sensor Default Settings - Option PIRHN						
Option	Dimmed State (unoccupied)	High Level (when occupied)	Photocell Operation	Dwell Time (occupancy time delay)	Ramp-up Time (from unoccupied to occupied)	Ramp-down Time (from occupied to unoccupied)
NLTAIR2 PIRHN	Approx. 30% Output	100% Output	Enabled @ 1.5FC	7.5 minutes	3 seconds	5 minutes

*Note: NLTAIR2 PIRHN default settings including photocell set-point, high/low dim rates, and occupancy sensor time delay are all configurable using the Clarity Pro App. Sensor coverage pattern shown with luminaire at 0°. Sensor coverage pattern is affected when luminaire is tilted.

FEATURES & SPECIFICATIONS

INTENDED USE

The RSX LED area family is designed to provide a long-lasting, energy-efficient solution for the one-for-one replacement of existing metal halide or high pressure sodium lighting. The RSX2 delivers 11,000 to 31,000 lumens and is ideal for replacing 250W to 1000W HID pole-mounted luminaires in parking lots and other area lighting applications.

CONSTRUCTION AND DESIGN

The RSX LED area luminaire features a rugged die-cast aluminum main body that uses heat-dissipating fins and flow-through venting to provide optimal thermal management that both enhances LED performance and extends component life. Integral "no drill" mounting arm allows the luminaire to be mounted on existing pole drillings, greatly reducing installation labor. The light engines and housing are sealed against moisture and environmental contaminants to IP66. The low-profile design results in a low EPA, allowing pole optimization. Vibration rated per ANSI C136.31: 3G Mountings: Include SPA, RPA, MA, IS, AASP, AARP rated for 3G vibration. 1.5G Mountings: Include WBA, WBASC, AAWB and AAWSC rated for 1.5G vibration.

FINISH

Exterior parts are protected by a zinc-infused Super Durable TGIC thermoset powder coat finish that provides superior resistance to corrosion and weathering. A tightly controlled multi-stage process ensures superior adhesion as well as a minimum finish thickness of 3 mils. The result is a high-quality finish that is warrantied not to crack or peel.

OPTICS

Precision acrylic refractive lenses are engineered for superior application efficiency, distributing the light to where it is needed most. Available in short and wide pattern distributions including Type 2, Type 3, Type 3S, Type 4, Type 4S, Type 5, Type 5S, AFR (Automotive Front Row) and AFR rotated AFRR90 and ARFL90.

COASTAL CONSTRUCTION (CCE)

Optional corrosion resistant construction is engineered with added corrosion protection in materials and/or pre-treatment of base material under super durable paint. Provides additional corrosion protection for applications near coastal areas. Finish is salt spray tested to over 5,000 hours per ASTM B117 with scribe rating of 10. Additional lead-times apply.

ELECTRICAL

Light engine(s) configurations consist of high-efficacy LEDs mounted on metal-core circuit boards and aluminum heat sinks to maximize heat dissipation. Light engines are IP66 rated. LED lumen maintenance is >L92/100,000 hours. CCT's of 3000K, 4000K and 5000K (minimum 70 CRI) are available. Fixtures ship standard with 0-10v dimming driver. Class 1 electronic drivers ensure system power factor >90% and THD <20%. Easily serviceable 10kV surge protection device meets a minimum Category C Low operation (per ANSI/IEEE C62.41.2).

STANDARD CONTROLS

The RSX LED area luminaire has a wide assortment of control options. Dusk to dawn controls include MVOLT and 347V button-type photocells and NEMA twist-lock photocell receptacles.

nLIGHT AIR CONTROLS

The RSX LED area luminaire is also available with nLight® AIR for the ultimate in wireless control. This powerful controls platform provides out-of-the-box basic motion sensing with photocontrol functionality and is suitable for mounting heights up to 40 feet. No commissioning is required when using factory default settings that provide basic stand-alone motion occupancy dimming that is switched on and off with a built-in photocell. See chart above for motion sensor default out-of-box settings. For more advanced wireless functionality, such as group dimming, nLight AIR can be commissioned using a smartphone and the easy-to-use CLAIRITY app. nLight AIR equipped luminaires can be grouped, resulting in motion sensor and photocell group response without the need for additional equipment. Scheduled dimming with motion sensor over-ride can be achieved when used with the nLight Eclipse. Additional information about nLight Air can be found [here](#).

INSTALLATION

Integral "no-drill" mounting arm allows for fast, easy mounting using existing pole drillings. Select the "SPA" option for square poles and the "RPA" option to mount to round poles. Note, the RPA mount can also be used for mounting to square poles by omitting the RPA adapter plate. Select the "MA" option to attach the luminaire to a 2 3/8" horizontal mast arm or the "IS" option for an adjustable slipfitter that mounts on a 2 3/8" OD tenon. The adjustable slipfitter has an integral junction box and offers easy installation. Can be tilted up to 90° above horizontal. Additional mountings are available including a wall bracket, adjustable tilt arm for direct-to-pole and wall and a surface conduit box for wall mount applications.

LISTINGS

CSA Certified to meet U.S. and Canadian standards. Suitable for wet locations. Rated for -40°C minimum ambient. DesignLights Consortium® (DLC) Premium qualified product and DLC qualified product. Not all versions of this product may be DLC Premium qualified or DLC qualified. Please check the DLC Qualified Products List at www.designlights.org/QPL to confirm which versions are qualified.

International Dark-Sky Association (IDA) Fixture Seal of Approval (FSA) is available for all products on this page utilizing 3000K color temperature only. US Patent No. D882, 146S

BUY AMERICAN ACT

Product with the BAA option is assembled in the USA and meets the Buy America(n) government procurement requirements under FAR, DFARS and DOT regulations. Please refer to www.acuitybrands.com/buy-american for additional information.

WARRANTY

5-year limited warranty. This is the only warranty provided and no other statements in this specification sheet create any warranty of any kind. All other express and implied warranties are disclaimed. Complete warranty terms located at:

www.acuitybrands.com/support/warranty/terms-and-conditions

Note: Actual performance may differ as a result of end-user environment and application. All values are design or typical values, measured under laboratory conditions at 25 °C. Specifications subject to change without notice.





MERU Series

LED GENERAL & EMERGENCY LIGHTING



PROJECT: _____
 FIXTURE TYPE: **MERU-LED-ACEM-DB**
 LOCATION: _____
 CONTACT/PHONE: _____

PRODUCT DESCRIPTION

The MERU Series is an architectural, low-profile outdoor light, offering “normally On” AC and emergency lighting with powerful LED illumination. The housing is fully sealed and gasketed, and has an IP65 rating. Designed for wall mounting with universal K/O pattern in back-plate for easy installation to most standard size junction boxes. Includes a single 1/2” NPT conduit entry in the top, center of the housing. Illumination provided by 8 high power LEDs which achieve 1,600 lumens in AC and 600 lumens in emergency. LED color at 4000K.

PRODUCT SPECIFICATIONS

CONSTRUCTION

Die cast aluminum housing with superior heat sink • Scratch resistant Polyester powder coat finish • UV resistant polycarbonate lens • Snap-fit housing and mounting plate are held together by four stainless steel clips • Universal mounting pattern molded into the back plate • 1/2" threaded top access for surface conduit installation • Silicone rubber seal with hollow center, shape adaptive design protects the electrical components • Junction box neoprene seal is attached to the back plate for a weather proof installation • Dark Bronze or White textured finish.

ELECTRICAL

Dual Voltage 120-277V 60Hz input • Solid state charging and switching • Battery low voltage disconnect • AC power indicator and test switch at the bottom of the unit • Standard with Self Diagnostics to monitor proper operation.

LAMPS

Supplied with eight (8) LG SMD 4000K LED'S • L70 > 72,000hours • 17 Watts total (32 Watts with IH option) • 1600 Lumens in AC mode, 600 Lumens in Emergency mode • Full cut-off optics for Dark Sky compliance

BATTERY

Maintenance-free, long-life rechargeable NiCad battery will operate fixture for a minimum of 90 minutes in the event of a power outage • 24 hour recharge after 90 minute discharge.

CODE COMPLIANCE

UL924 • Listed for wet location applications (0°C-50°C) • Optional "IH" cold weather package for (-40°C-50°C) • IP65 Rated • NFPA 101 Life Safety Code compliant • NEC and OSHA compliant • DLC Listed • RoHS Compliant

WARRANTY

5-year warranty. Product specifications subject to change without notice.

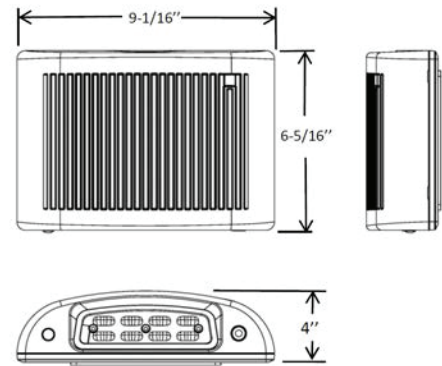

ACEM Model (NiCad Battery Backup)

Integral photocell: Unit operates as a dusk to dawn luminaire and in the event of a power failure as an emergency light.

Remote Switched: The integral photocell can be defeated to allow remote switching for normal operation. In the event of a power failure unit operates as an emergency light.

INSTALLATION

MOUNTING

Suitable for indoor or outdoor wall mounting on junction box, or with surface conduit using the supplied 1/2" threaded top access • Mounting plate has molded universal mounting pattern for simple mounting over junction box.

ORDERING INFORMATION

model	operation mode	housing color	options
MERU-LED	ACEM = General & Emergency Lighting AC = General Lighting	DB = Dark Bronze WH = White BK = Black NK = Nickel	Self-Diagnostics & Photocell (Included Standard) IH = Internal Heater
Ordering Example: MERU-ACEM-DB			





MERU Series

LED GENERAL & EMERGENCY LIGHTING



PROJECT: _____
 FIXTURE TYPE: _____
 LOCATION: _____
 CONTACT/PHONE: _____

PHOTOMETRICS

3ft Path Spacing

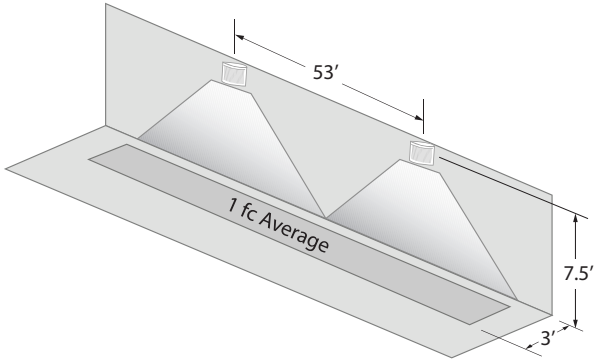

6ft Path Spacing

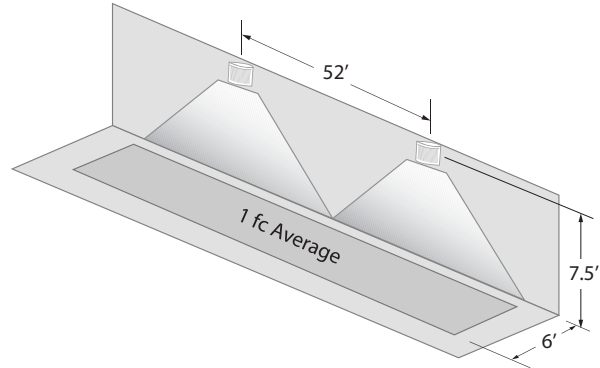

SELF DIAGNOSTICS

Included Self Diagnostic

Diagnostic Indicator / Test Switch	● Ready	Manual Testing Press button once - 1 minute test Press button twice - 5 minute test Press button 3 times - 30 minute test Press button 4 times - 90 minute test
	● In Test	
	● Battery Circuit Fault	
	● Battery Capacity Failure	
	● Charger Failure	
	● Transformer Fault	
● Lamp Failure		

Full self-test, self-diagnostic system is standard in every unit, performs a monthly, test as well as continuously monitoring all functions to ensure reliability, a manual test may be initiated at any time

