



---

690 Chesterfield Pkwy W • Chesterfield MO 63017-0760  
Phone: 636-537-4000 • Fax 636-537-4798 • www.chesterfield.mo.us

---

## Planning Commission Staff Report

Meeting Date: August 14<sup>th</sup>, 2023

From: Alyssa Ahner, Planner

Location: 34 Arnage Road

Description: TSG Chesterfield Airport Road, Lot D (Scrubbles) ASDSP: An Amended Site Development Section Plan, Lighting Plan, and Architectural Elevations for a 1.5-acre tract of land located north of Chesterfield Airport Rd., west of Jaguar Land Rover Way, and south of Arnage Rd.

---

### PROPOSAL SUMMARY

Stock & Associates, on behalf of Tifton Car Wash, LLC., has submitted an Amended Site Development Section Plan, Lighting Plan, and Architectural Elevations for a proposed car wash on undeveloped land located along Chesterfield Airport Road. This project was previously reviewed by Planning Commission on January 9, 2023 and the applicant is now seeking modifications to what was previously approved. This report only details the revisions that have been made.

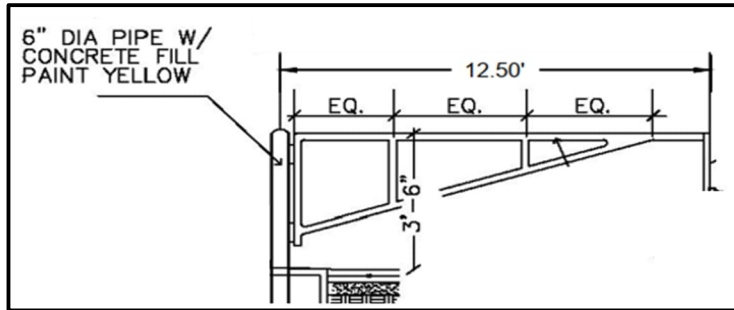

Figure 1: Subject Site

**STAFF ANALYSIS**

**A. Circulation, Parking, & Access**

The applicant is proposing two (2) gates on the subject site to restrict access when the business is closed. The shaded red areas in *Figure 3* depict the gate locations while *Figure 4* shows the elevation of the proposed swing gate.



*Figure 4: Proposed swing gate*

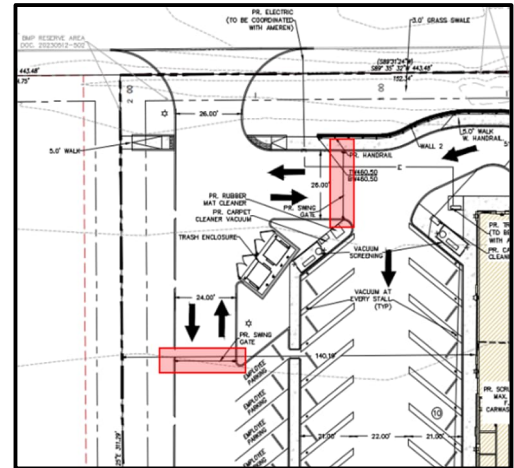

*Figure 3: Proposed gate locations*

**B. Architectural Elevations**

The last time this project was reviewed by Architectural Review Board, the applicant was proposing 4-inch style brick masonry. Per the applicant, there have been some necessary structural modifications thus an 8-inch style brick masonry is being requested in place of the 4-inch style. This will increase the height of the western building section to 16' which was previously approved as 15' 4". Lastly, there has been an addition of steel roll-up doors in dark bronze. These would be located in front of each vinyl roll-up door for security and would not be visible during business hours.

**C. Lighting**

There were previously five (5) light poles incorporated throughout the site. The applicant is requesting the same number of light poles but two would relocate by a few feet. A different brand/style is also being proposed as shown in *Figure 6* and *Figure 7*. The applicant is also seeking modifications to the previously approved wall packs. There are now six (6) wall packs and they are also being proposed in a different brand/style from what was previously approved as shown in *Figure 8* and *Figure 9*.



*Figure 6: Previously approved light pole*



*Figure 7: Proposed light pole*



*Figure 8: Previously approved wall pack*



*Figure 9: Proposed wall sconce*

The last modification includes the addition of LED strip lights between vacuum stations. These lights are indicated as blue dashes on the lighting plan and a cutsheet is also available in the Applicant's packet. All lighting has been found to be code compliant.

### ARCHITECTURAL REVIEW BOARD

This project and the modifications were reviewed by Architectural Review Board on July 13<sup>th</sup>, 2023. At that time, the Board made a motion to recommend approval, as presented.

### RENDERING



*Figure 10: View traveling east on Chesterfield Airport Road*

### DEPARTMENT INPUT

Staff has reviewed the Amended Site Development Section Plan, Lighting Plan, and Architectural Elevations and found that it meets the requirements to be presented to the Planning Commission for review. Staff recommends action.

### MOTION

The following options are provided to the Planning Commission for consideration relative to this application:

- 1) "I move to approve (or deny) the Amended Site Development Section Plan, Lighting Plan, and Architectural Elevations for TSG Chesterfield Airport Road, Lot D (Scrubbles), as presented.
- 2) "I move to approve the Amended Site Development Section Plan, Lighting Plan, and Architectural Elevations for TSG Chesterfield Airport Road, Lot D (Scrubbles) with the following conditions..."  
(Conditions may be added, eliminated, altered or modified)

Attachments:

1. Applicant Submittal Packet



ST. LOUIS LIGHTING GROUP  
7414 MANCHESTER RD  
SAINT LOUIS, MO 63143-3032  
Phone: 314-963-3311  
Fax: 314-963-7373  
Contact:

## Scrubbles Car Wash ~ Blanket for 4 locations

22-73934-21

6/27/2023



Project 22-73934-21  
Scrubbles Car Wash ~ Blanket for 4 locations

Submitted By  
ST. LOUIS LIGHTING GROUP

Type	Manufacturer/Brand	Catalog Number
A1B-T2R HSS	ABL-Lithonia Lighting	<a href="#">RSX2 LED P1 40K R2 MVOLT HS SPA DDBXD</a>
A2B-T4W- HSS	ABL-Lithonia Lighting	<a href="#">RSX2 LED P3 40K R4 MVOLT HS SPA DDBXD</a>
POLES	ABL-Lithonia Lighting	<a href="#">SSS 20 4C DM19AS DDBXD</a>
B	ABL-Lithonia Lighting	<a href="#">ZL1N L48 3000LM FST MVOLT 40K 80CRI WH</a>
B	ABL-Lithonia Lighting	<a href="#">HC36 M12</a>
WP	ABL-Lithonia Lighting	<a href="#">WDGE1 LED P2 40K 80CRI VF MVOLT SRM DDBXD</a>



## RSX2 LED Area Luminaire



### Specifications

<b>EPA</b> (ft <sup>2</sup> @0°):	0.69 ft <sup>2</sup> (0.06 m <sup>2</sup> )
<b>Length:</b>	29.3" (74.4 cm) (SPA mount)
<b>Width:</b>	13.4" (34.0 cm)
<b>Height:</b>	3.0" (7.6 cm) Main Body 7.2" (18.3 cm) Arm
<b>Weight:</b> (SPA mount)	30.0 lbs (13.6 kg)

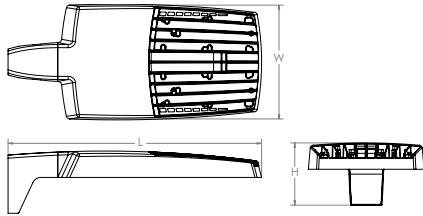

### Introduction

The new RSX LED Area family delivers maximum value by providing significant energy savings, long life and outstanding photometric performance at an affordable price. The RSX2 delivers 11,000 to 31,000 lumens allowing it to replace 250W to 1000W HID luminaires.

The RSX features an integral universal mounting mechanism that allows the luminaire to be mounted on most existing drill hole patterns. This "no-drill" solution provides significant labor savings. An easy-access door on the bottom of mounting arm allows for wiring without opening the electrical compartment. A mast arm adaptor, adjustable integral slipfitter and other mounting configurations are available.



Items marked by a shaded background qualify for the Design Select program and ship in 15 days or less. To learn more about Design Select, visit [www.acuitybrands.com/designselect](http://www.acuitybrands.com/designselect).  
\*See ordering tree for details

 Design Select options indicated by this color background.

### Ordering Information

### EXAMPLE: RSX2 LED P6 40K R3 MVOLT SPA DDBXD

RSX2 LED	P1	40K	R2	MVOLT	SPA
Series	Performance Package	Color Temperature	Distribution	Voltage	Mounting
RSX2 LED	<b>P1</b>	30K 3000K	<b>R2</b> Type 2 Wide	<b>MVOLT</b> (120V-277V) <sup>2</sup>	<b>SPA</b> Square pole mounting (3.0" min. SQ pole for 1 at 90°, 3.5" min. SQ pole for 2, 3, 4 at 90°)
	P2	<b>40K</b> 4000K	R3 Type 3 Wide	HVOLT (347V-480V) <sup>3</sup>	RPA Round pole mounting (3.2" min. dia. RND pole for 2, 3, 4 at 90°, 3.0" min. dia. RND pole for 1 at 90°, 2 at 180°, 3 at 120°)
	P3	50K 5000K	R3S Type 3 Short	XVOLT (277V-480V) <sup>4</sup>	MA Mast arm adaptor (fits 2-3/8" OD horizontal tenon)
	P4		R4 Type 4 Wide	(use specific voltage for options as noted)	IS Adjustable slipfitter (fits 2-3/8" OD tenon) <sup>6</sup>
	P5		R4S Type 4 Short	120 <sup>3</sup> 277 <sup>5</sup>	WBA Wall bracket <sup>1</sup>
	P6		R5 Type 5 Wide <sup>1</sup>	208 <sup>3</sup> 347 <sup>5</sup>	WBASC Wall bracket with surface conduit box
			R5S Type 5 Short <sup>1</sup>	240 <sup>3</sup> 480 <sup>5</sup>	AASP Adjustable tilt arm square pole mounting <sup>6</sup>
		AFR Automotive Front Row		AARP Adjustable tilt arm round pole mounting <sup>6</sup>	
		AFRR90 Automotive Front Row Right Rotated		AAWB Adjustable tilt arm with wall bracket <sup>6</sup>	
		AFRL90 Automotive Front Row Left Rotated		AAWSC Adjustable tilt arm wall bracket and surface conduit box <sup>6</sup>	

HS	DDBXD
Options	Finish
<b>Shipped Installed</b>	<b>DDBXD</b> Dark Bronze
HS House-side shield <sup>7</sup>	DBLXD Black
PE Photocontrol, button style <sup>8,9</sup>	DNAXD Natural Aluminum
PER7 Seven-wire twist-lock receptacle only (no controls) <sup>9,10,11</sup>	DWHXD White
SF Single fuse (120, 277, 347) <sup>5</sup>	DDBTXD Textured Dark Bronze
DF Double fuse (208, 240, 480) <sup>5</sup>	DBLBXD Textured Black
SPD20KV 20KV Surge pack (10KV standard)	DNATXD Textured Natural Aluminum
FAO Field adjustable output <sup>9</sup>	DWHGXD Textured White
DMG 0-10V dimming extend out back of housing for external control (control ordered separate) <sup>9</sup>	
DS Dual switching <sup>8,12</sup>	
<b>Shipped Installed</b>	
<b>*Standalone and Networked Sensors/Controls (factory default settings, see table page 9)</b>	
NLTAIR2 PIRHN nLight AIR generation 2, with Networked, Bi-Level motion/ambient sensor <sup>9,13,14,15</sup>	
BAA Buy America(n) Act Compliant	
CCE Coastal Construction <sup>16</sup>	
<b>*Note: NLTAIR2 PIRHN with nLight Air can be used as a standalone dimming sensor with out-of-box settings or as a wireless networked solution. See factory default settings table. Sensor coverage pattern is affected when luminaire is tilted.</b>	
<b>Shipped Separately (requires some field assembly)</b>	
EGS External glare shield <sup>7</sup>	
EGFV External glare full visor (360° around light aperture) <sup>7</sup>	
BS Bird spikes <sup>17</sup>	



## Ordering Information

### Accessories

Ordered and shipped separately.

RSX2HS	RSX2 House side shield (includes 2 shields)
RSX2EGS (FINISH) U	External glare shield (specify finish)
RSX2HSAFRR (FINISH) U	RSX2 House side shields for AFR rotated optics (includes 2 shields)
RSX2EGFV (FINISH) U	External glare full visor (specify finish)
RSXRPA (FINISH) U	RSX Universal round pole adaptor plate (specify finish)
RSXWBA (FINISH) U	RSX WBA wall bracket (specify finish) <sup>1</sup>
RSXSCB (FINISH) U	RSX Surface conduit box (specify finish, for use with WBA, WBA not included)
DLL127F 1.5 JU	Photocell -SSL twist-lock (120-277V) <sup>18</sup>
DLL347F 1.5 CUL JU	Photocell -SSL twist-lock (347V) <sup>18</sup>
DLL480F 1.5 CUL JU	Photocell -SSL twist-lock (480V) <sup>18</sup>
DSHORT SBK U	Shorting cap <sup>18</sup>

### NOTES

- Any Type 5 distribution, is not available with WBA.
- MVOLT driver operates on any line voltage from 120-277V (50/60 Hz).
- HVOLT driver operates on any line voltage from 347-480V (50/60 Hz).
- XVOLT driver not available with P1. XVOLT driver operates on any line voltage from 277V-480V (50/60 Hz). XVOLT not available with fusing (SF or DF) and not available with PE.
- Single fuse (SF) requires 120V, 277V or 347V. Double fuse (DF) requires 208V, 240V or 480V.
- Maximum tilt is 90° above horizontal.
- It may be ordered as an accessory.
- Requires MVOLT or 347V.
- Two or more of the following options cannot be combined including PE, DMG, PER7, FAO, DS and NLTAIR2 PIRHN. (Exception: PE and FAO can be combined; also PE and DMG can be combined.)
- Compatible with standard twist-lock photocells for dusk to dawn operation or advanced control nodes that provide 0-10V dimming signals. Wire 4/Wire 5 wired to dimming leads on driver. Wire6/Wire7 capped inside luminaire. Twistlock photocell ordered and shipped

as a separate line item from Acuity Brands Controls. See accessories. Shorting Cap included.

- For units with option PER7, the mounting must be restricted to +/- 45° from horizontal aim per ANSI C136.10-2010.
- DS requires (2) separately switched circuits. DS provides 50/50 fixture operation via (2) different sets of leads using (2) drivers. DS only available with packages P5 and P6.
- Must be ordered with PIRHN.
- Requires MVOLT or HVOLT.
- Must be ordered with NLTAIR2. For additional information on PIRHN visit [here](#).
- CCE option not available with WBA, WBA, AASP, AARP, AAWB, AAWBSC, EGS, EGFV and BS.
- Must be ordered with fixture for factory pre-drilling.
- Requires luminaire to be specified with PER7 option. Ordered and shipped as a separate line item from Acuity Brands Controls.

## External Shields



House Side Shield



External Glare Shield



External 360 Full Visor

## Pole/Mounting Information

Accessories including bullhorns, cross arms and other adapters are available under the accessories tab at Lithonia's Outdoor Poles and Arms product page. Click here to visit [Accessories](#).

### HANDHOLE ORIENTATION

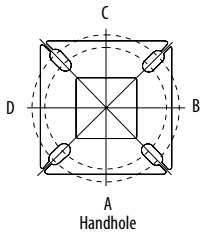

### RSX POLE DRILLING

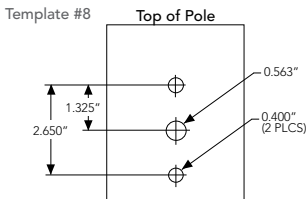

### RSX STANDARD ARM & ADJUSTABLE ARM

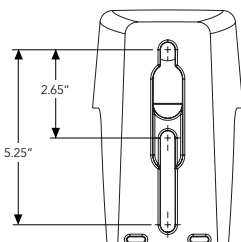

### Round Tenon Mount - Pole Top Slipfitters

Tenon O.D.	RSX Mounting	Single	2 at 180°	2 at 90°	3 at 120°	3 at 90°	4 at 90°
2 - 3/8"	RPA, AARP	AS3-5 190	AS3-5 280	AS3-5 290	AS3-5 320	AS3-5 390	AS3-5 490
2 - 7/8"	RPA, AARP	AST25-190	AST25-280	AST25-290	AST25-320	AST25-390	AST25-490
4"	RPA, AARP	AST35-190	AST35-280	AST35-290	AST35-320	AST35-390	AST35-490

### Drill/Side Location by Configuration Type

Drilling Template	Mounting Option	Single	2 @ 180	2 @ 90	3 @ 120	3 @ 90	4 @ 90
	Head Location	Side B	Side B & D	Side B & C	Round Pole Only	Side B, C & D	Side A, B, C & D
#8	Drill Nomenclature	DM19AS	DM28AS	DM29AS	DM32AS	DM39AS	DM49AS

### RSX2 - Luminaire EPA

\*Includes luminaire and integral mounting arm. Other tenons, arms, brackets or other accessories are not included in this EPA data.

Fixture Quantity & Mounting Configuration	Single	2 @ 90	2 @ 180	3 @ 90	3 @ 120	4 @ 90	2 Side by Side	3 Side by Side	4 Side by Side	
SPA - Square Pole Adaptor	0.69	1.22	1.27	1.8	1.61	2.39	1.37	2.06	2.74	
RPA - Round Pole Adaptor	0.74	1.27	1.37	1.9	1.71	2.49	1.42	2.16	2.84	
MA - Mast Arm Adaptor	0.61	1.14	1.11	1.64	1.45	2.23	1.29	1.9	2.58	
IS - Integral Slipfitter AASP/AARP - Adjustable Arm Square/Round Pole	0°	0.69	1.22	1.27	1.8	1.61	2.39	1.37	2.06	2.74
	10°	0.53	1.06	1.05	1.58	1.37	2.08	1.06	1.59	2.12
	20°	0.52	1.02	1.03	1.52	1.33	2.02	1.03	1.55	2.07
	30°	0.64	1.11	1.18	1.63	1.45	2.21	1.27	1.91	2.54
	40°	0.81	1.21	1.35	1.74	1.65	2.39	1.62	2.43	3.23
	45°	0.91	1.25	1.5	1.81	1.75	2.48	1.82	2.73	3.64
	50°	1.34	1.83	2.17	2.61	2.56	3.62	2.68	4.02	5.36
	60°	2.2	2.97	3.57	4.24	4.17	5.89	4.41	6.61	8.82
	70°	2.86	4.13	4.7	5.89	5.71	8.21	5.71	8.57	11.42
	80°	3.4	5.13	5.67	7.34	7.09	10.21	6.79	10.19	13.59
90°	3.85	5.96	6.55	8.58	8.31	11.88	7.70	11.56	15.41	

## Photometric Diagrams

To see complete photometric reports or download .ies files for this product, visit Lithonia Lighting's RSX Area homepage.

Isofootcandle plots for the RSX2 LED P6 40K. Distances are in units of mounting height (30').

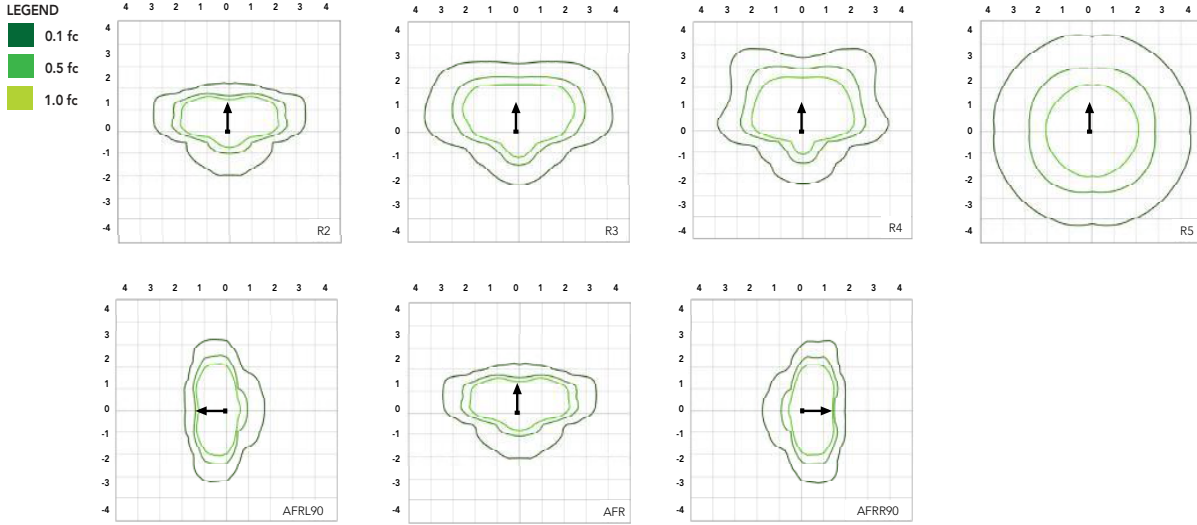

## Performance Data

### Lumen Ambient Temperature (LAT) Multipliers

Use these factors to determine relative lumen output for average ambient temperatures from 0-50°C (32-122°F).

Ambient	Ambient	Lumen Multiplier
0°C	32°F	1.05
5°C	41°F	1.04
10°C	50°F	1.03
15°C	59°F	1.02
20°C	68°F	1.01
25°C	77°F	1.00
30°C	86°F	0.99
35°C	95°F	0.98
40°C	104°F	0.97
45°C	113°F	0.96
50°C	122°F	0.95

### Electrical Load

Performance Package	System Watts (W)	Current (A)					
		120V	208V	240V	277V	347V	480V
P1	71W	0.59	0.34	0.30	0.26	0.20	0.15
P2	111W	0.93	0.53	0.46	0.40	0.32	0.23
P3	147W	1.23	0.70	0.61	0.53	0.42	0.31
P4	187W	1.55	0.90	0.78	0.68	0.53	0.38
P5	210W	1.75	1.01	0.87	0.76	0.60	0.44
P6	244W	2.03	1.17	1.01	0.88	0.70	0.51

### Projected LED Lumen Maintenance

Operating Hours	50,000	75,000	100,000
Lumen Maintenance Factor	>0.97	>0.95	>0.92

Values calculated according to IESNA TM-21-11 methodology and valid up to 40°C.





Project 22-73934-21  
Scrubbles Car Wash ~ Blanket for 4 locations

Submitted By  
ST. LOUIS LIGHTING GROUP

Catalog Number: RSX2 LED P1 40K R2 MVOLT HS SPA  
DDBXD

Note:

Type  
A1B-T2R HSS

## Performance Data

### Lumen Output

Lumen values are from photometric tests performed in accordance with IESNA LM-79-08. Data is considered to be representative of the configurations shown, within the tolerances allowed by Lighting Facts. Contact factory for performance data on any configurations not shown here.

Performance Package	System Watts	Distribution Type	30K (3000K, 70 CRI)					40K (4000K, 70 CRI)					50K (5000K, 70 CRI)				
			Lumens	B	U	G	LPW	Lumens	B	U	G	LPW	Lumens	B	U	G	LPW
P1	71W	R2	10,040	2	0	1	139	11,031	2	0	1	153	11,031	2	0	1	153
		R3	10,005	2	0	2	141	10,992	2	0	2	155	10,992	2	0	2	155
		R3S	10,271	2	0	2	143	11,285	2	0	2	157	11,285	2	0	2	157
		R4	10,136	2	0	2	143	11,136	2	0	2	157	11,136	2	0	2	157
		R4S	9,779	2	0	2	138	10,744	2	0	2	151	10,744	2	0	2	151
		R5	10,271	4	0	2	145	11,285	4	0	2	159	11,285	4	0	2	159
		R5S	10,544	3	0	1	149	11,585	3	0	2	163	11,585	3	0	2	163
		AFR	10,026	2	0	1	141	11,016	2	0	1	155	11,016	2	0	1	155
		AFRR90	10,122	3	0	2	140	11,121	3	0	2	154	11,121	3	0	2	154
		AFRL90	10,164	3	0	2	141	11,167	3	0	2	155	11,167	3	0	2	155
		R2	15,712	2	0	2	138	17,263	2	0	2	151	17,263	2	0	2	151
		R3	15,657	2	0	3	141	17,202	3	0	3	155	17,202	3	0	3	155
R3S	16,075	2	0	2	141	17,661	2	0	2	155	17,661	2	0	2	155		
R4	15,862	2	0	3	143	17,427	2	0	3	157	17,427	2	0	3	157		
R4S	15,304	2	0	2	138	16,815	2	0	2	151	16,815	2	0	2	151		
R5	16,075	4	0	2	145	17,661	5	0	3	159	17,661	5	0	3	159		
R5S	16,502	4	0	2	149	18,130	4	0	2	163	18,130	4	0	2	163		
AFR	15,691	2	0	2	141	17,240	2	0	2	155	17,240	2	0	2	155		
AFRR90	15,841	3	0	3	139	17,404	4	0	3	153	17,404	4	0	3	153		
AFRL90	15,907	3	0	3	139	17,477	4	0	3	153	17,477	4	0	3	153		
R2	19,855	3	0	2	132	21,814	3	0	2	145	21,814	3	0	2	145		
R3	19,785	3	0	3	135	21,737	3	0	4	148	21,737	3	0	4	148		
R3S	20,312	3	0	3	135	22,317	3	0	3	149	22,317	3	0	3	149		
R4	20,044	3	0	3	136	22,022	3	0	4	150	22,022	3	0	4	150		
R4S	19,339	3	0	3	132	21,247	3	0	3	145	21,247	3	0	3	145		
R5	20,313	5	0	3	138	22,317	5	0	3	152	22,317	5	0	3	152		
R5S	20,852	4	0	2	142	22,910	4	0	2	156	22,910	4	0	2	156		
AFR	19,828	3	0	2	135	21,785	3	0	2	148	21,785	3	0	2	148		
AFRR90	20,017	4	0	3	133	21,992	4	0	3	147	21,992	4	0	3	147		
AFRL90	20,101	4	0	3	134	22,084	4	0	3	147	22,084	4	0	3	147		
R2	22,836	3	0	2	120	25,090	3	0	2	132	25,090	3	0	2	132		
R3	22,756	3	0	4	122	25,002	3	0	4	134	25,002	3	0	4	134		
R3S	23,363	3	0	3	123	25,668	3	0	3	135	25,668	3	0	3	135		
R4	23,054	3	0	4	123	25,329	3	0	4	135	25,329	3	0	4	135		
R4S	22,243	3	0	3	119	25,059	3	0	3	134	25,059	3	0	3	134		
R5	23,363	5	0	3	125	25,669	5	0	4	137	25,669	5	0	4	137		
R5S	23,983	4	0	2	128	26,350	4	0	2	141	26,350	4	0	2	141		
AFR	22,806	3	0	2	122	25,056	3	0	2	134	25,056	3	0	2	134		
AFRR90	23,023	4	0	3	121	25,295	4	0	3	133	25,295	4	0	3	133		
AFRL90	23,120	4	0	3	122	25,401	4	0	3	134	25,401	4	0	3	134		
R2	26,141	3	0	2	122	28,721	3	0	2	135	28,721	3	0	2	135		
R3	26,049	3	0	4	124	28,620	3	0	4	136	28,620	3	0	4	136		
R3S	26,744	3	0	3	125	29,383	3	0	4	138	29,383	3	0	4	138		
R4	26,390	3	0	4	126	28,994	3	0	4	138	28,994	3	0	4	138		
R4S	25,462	3	0	3	121	27,974	3	0	3	133	27,974	3	0	3	133		
R5	26,744	5	0	4	127	29,383	5	0	4	140	29,383	5	0	4	140		
R5S	27,454	4	0	2	131	30,163	4	0	2	144	30,163	4	0	2	144		
AFR	26,106	3	0	2	124	28,682	3	0	2	137	28,682	3	0	2	137		
AFRR90	26,354	4	0	3	123	28,955	5	0	3	136	28,955	5	0	3	136		
AFRL90	26,465	4	0	3	124	29,077	5	0	3	136	29,077	5	0	3	136		
R2	27,646	3	0	2	112	30,374	3	0	2	123	30,374	3	0	2	123		
R3	27,549	3	0	4	113	30,267	3	0	4	124	30,267	3	0	4	124		
R3S	28,283	3	0	3	115	31,075	3	0	4	126	31,075	3	0	4	126		
R4	27,909	3	0	4	114	30,663	3	0	4	126	30,663	3	0	4	126		
R4S	26,928	3	0	3	110	29,585	3	0	3	121	29,585	3	0	3	121		
R5	28,284	5	0	4	116	31,075	5	0	4	127	31,075	5	0	4	127		
R5S	29,035	4	0	2	119	31,900	5	0	3	131	31,900	5	0	3	131		
AFR	27,608	3	0	2	112	30,332	3	0	2	123	30,332	3	0	2	123		
AFRR90	27,872	4	0	3	113	30,622	5	0	3	124	30,622	5	0	3	124		
AFRL90	27,989	4	0	3	113	30,751	5	0	3	125	30,751	5	0	3	125		

## Dimensions & Weights

### Luminaire Weight by Mounting Type

Mounting Configuration	Total Luminaire Weight
SPA	30 lbs
RPA	32 lbs
MA	30 lbs
WBA	33 lbs
WBASC	36 lbs
IS	33 lbs
AASP	33 lbs
AARP	35 lbs
AAWB	36 lbs
AAWSC	39 lbs

### RSX2 with Round Pole Adapter (RPA)

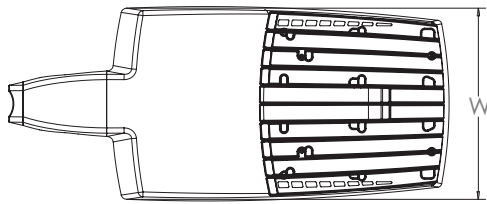

Length: 30.3" (77.0 cm)  
Width: 13.4" (34.0 cm)  
Height: 3.0" (7.6 cm) Main Body  
7.2" (18.3 cm) Arm

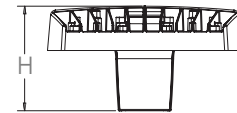
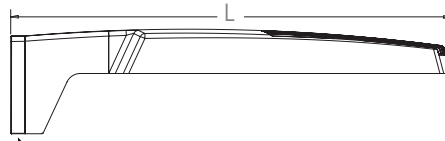

Note: RPA — Round Pole mount can also be used to mount on square poles by omitting the round pole adapter plate shown here.



### RSX2 with Mast Arm Adapter (MA)

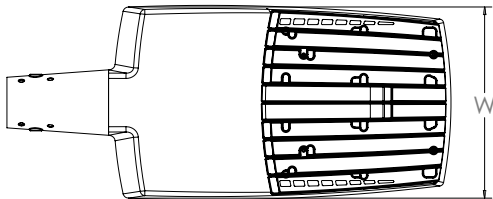

Length: 30.6" (77.7 cm)  
Width: 13.4" (34.0 cm)  
Height: 3.0" (7.6 cm) Main Body  
3.5" (8.9 cm) Arm

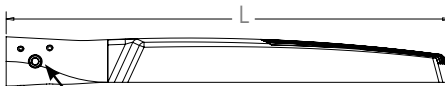

7/16" locking thru bolt/nut provided

### RSX2 with Adjustable Slipfitter (IS)

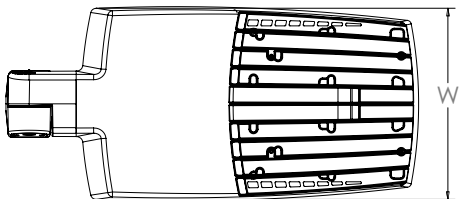

Length: 28.3" (71.9 cm)  
Width: 13.4" (34.0 cm)  
Height: 3.0" (7.6 cm) Main Body  
7.6" (19.3 cm) Arm

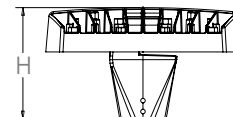
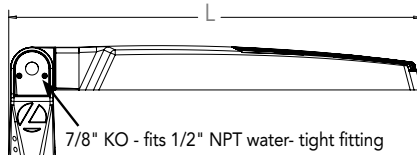

7/8" KO - fits 1/2" NPT water-tight fitting

## Dimensions

### RSX2 with Wall Bracket (WBA)

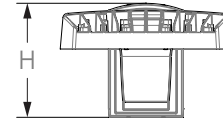
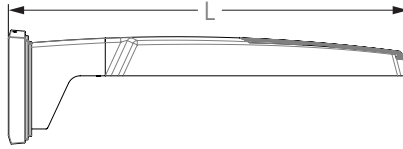
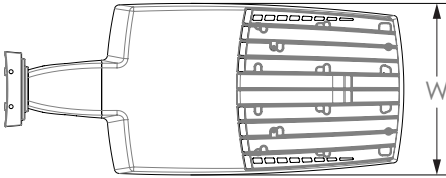

Length: 31.2" (79.2 cm)  
Width: 13.4" (41.7 cm)  
Height: 3.0" (7.6 cm) Main Body  
8.9" (22.6 cm) Arm

### Wall Bracket (WBA) Mounting Detail

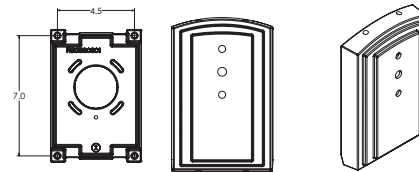

### RSX2 with Wall Bracket with Surface Conduit Box (WBASC)

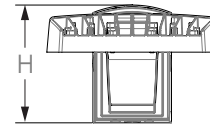
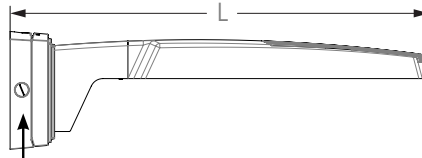
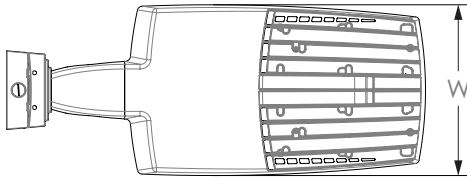

3/4" NPT taps with plugs - Qty (4) provided

Length: 32.8" (83.3 cm)  
Width: 13.4" (41.7 cm)  
Height: 3.0" (7.6 cm) Main Body  
9.2" (23.4 cm) Arm

### Surface Conduit Box (SCB) Mounting Detail

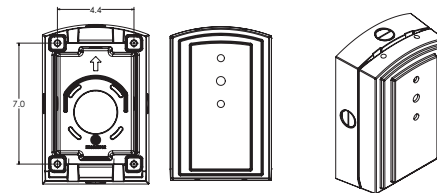

## Dimensions

### RSX2 with Adjustable Tilt Arm - Square or Round Pole (AASP or AARP)

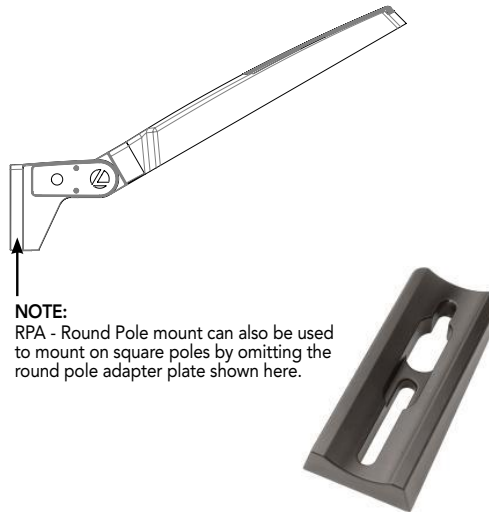
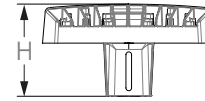
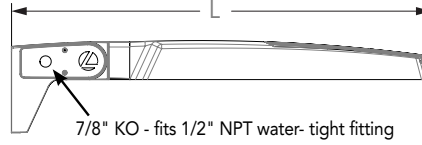
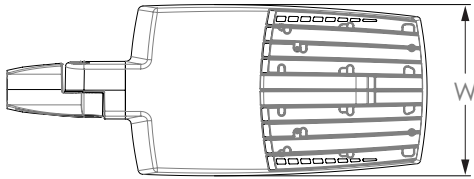

**NOTE:**  
RPA - Round Pole mount can also be used to mount on square poles by omitting the round pole adapter plate shown here.

Length: 32.8" (83.3 cm) **AASP**  
33.8" (85.9 cm) **AARP**  
Width: 13.4" (34.0 cm)  
Height: 3.0" (7.6 cm) Main Body  
7.2" (18.2 cm) Arm

**Notes**  
AASP: Requires 3.0" min. square pole for 1 at 90°. Requires 3.5" min. square pole for mounting 2, 3, 4 at 90°.  
AARP: Requires 3.2" min. dia. round pole for 2, 3, 4 at 90°. Requires 3.0" min. dia. round pole for mounting 1 at 90°, 2 at 180°, 3 at 120°.

### RSX2 with Adjustable Tilt Arm with Wall Bracket (AAWB)

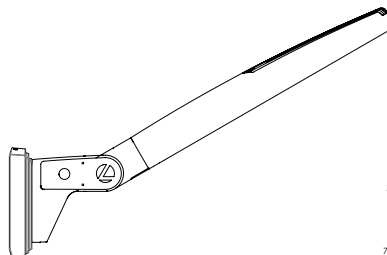
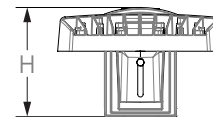
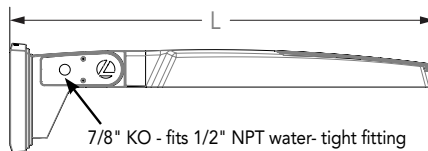
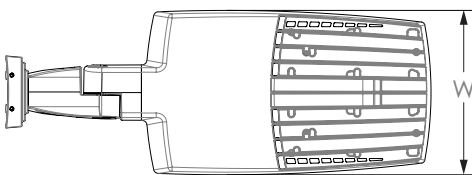

#### Wall Bracket (WBA) Mounting Detail

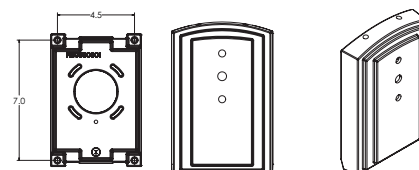

Length: 34.7" (88.0 cm)  
Width: 13.4" (34.0 cm)  
Height: 3.0" (7.6 cm) Main Body  
8.9" (22.6 cm) Arm

## Dimensions

### RSX2 with Adjustable Tilt Arm with Wall Bracket and Surface Conduit Box (AAWSC)

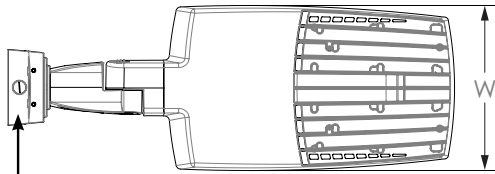

3/4" NPT taps  
with plugs - Qty (4)  
provided

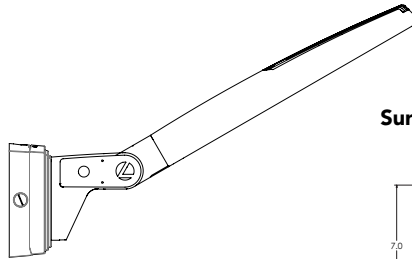
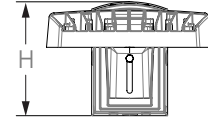
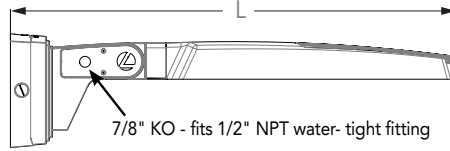

Length: 36.2" (91.9 cm)  
Width: 13.4" (40.0 cm)  
Height: 3.0" (7.6 cm) Main Body  
9.2" (23.4 cm) Arm

### Surface Conduit Box (SCB) Mounting Detail

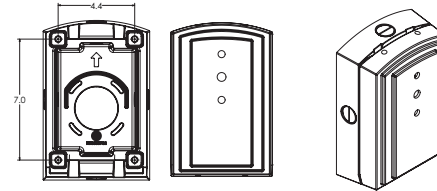

### Automotive Front Row - Rotated Optics (AFRL90/R90)

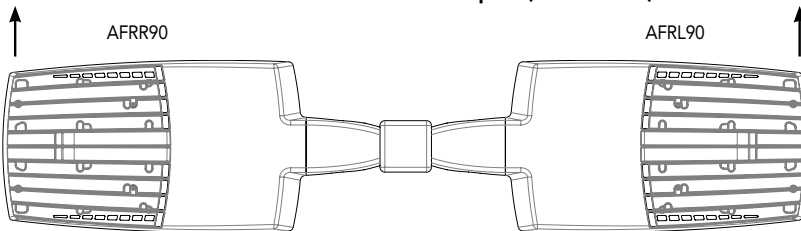

(Example: 2@180 - arrows indicate direction of light exiting the luminaire)

## nLight Control - Sensor Coverage and Settings

### NLTAIR2 PIRHN nLight Sensor Coverage Pattern nLight PIRHN

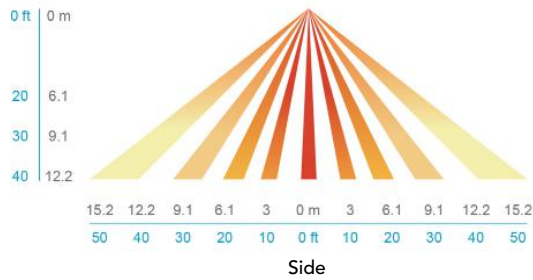
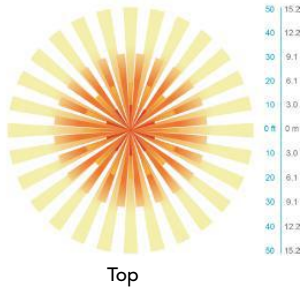
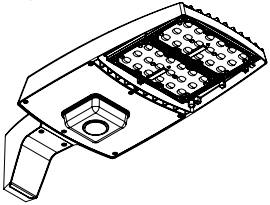

Motion Sensor Default Settings - Option PIRHN						
Option	Dimmed State (unoccupied)	High Level (when occupied)	Photocell Operation	Dwell Time (occupancy time delay)	Ramp-up Time (from unoccupied to occupied)	Ramp-down Time (from occupied to unoccupied)
NLTAIR2 PIRHN	Approx. 30% Output	100% Output	Enabled @ 1.5FC	7.5 minutes	3 seconds	5 minutes

\*Note: NLTAIR2 PIRHN default settings including photocell set-point, high/low dim rates, and occupancy sensor time delay are all configurable using the Clairity Pro App. Sensor coverage pattern shown with luminaire at 0°. Sensor coverage pattern is affected when luminaire is tilted.

## FEATURES & SPECIFICATIONS

### INTENDED USE

The RSX LED area family is designed to provide a long-lasting, energy-efficient solution for the one-for-one replacement of existing metal halide or high pressure sodium lighting. The RSX2 delivers 11,000 to 31,000 lumens and is ideal for replacing 250W to 1000W HID pole-mounted luminaires in parking lots and other area lighting applications.

### CONSTRUCTION AND DESIGN

The RSX LED area luminaire features a rugged die-cast aluminum main body that uses heat-dissipating fins and flow-through venting to provide optimal thermal management that both enhances LED performance and extends component life. Integral "no drill" mounting arm allows the luminaire to be mounted on existing pole drillings, greatly reducing installation labor. The light engines and housing are sealed against moisture and environmental contaminants to IP66. The low-profile design results in a low EPA, allowing pole optimization. Vibration rated per ANSI C136.31; 3G Mountings: Include SPA, RPA, MA, IS, AASP, AARP rated for 3G vibration. 1.5G Mountings: Include WBA, WBASC, AAWB and AAWSC rated for 1.5G vibration.

### FINISH

Exterior parts are protected by a zinc-infused Super Durable TGIC thermoset powder coat finish that provides superior resistance to corrosion and weathering. A tightly controlled multi-stage process ensures superior adhesion as well as a minimum finish thickness of 3 mils. The result is a high-quality finish that is warranted not to crack or peel.

### OPTICS

Precision acrylic refractive lenses are engineered for superior application efficiency, distributing the light to where it is needed most. Available in short and wide pattern distributions including Type 2, Type 3, Type 3S, Type 4, Type 4S, Type 5, Type 5S, AFR (Automotive Front Row) and AFR rotated AFR90 and ARFL90.

### COASTAL CONSTRUCTION (CCE)

Optional corrosion resistant construction is engineered with added corrosion protection in materials and/or pre-treatment of base material under super durable paint. Provides additional corrosion protection for applications near coastal areas. Finish is salt spray tested to over 5,000 hours per ASTM B117 with scribe rating of 10. Additional lead-times apply.

### ELECTRICAL

Light engine(s) configurations consist of high-efficacy LEDs mounted on metal-core circuit boards and aluminum heat sinks to maximize heat dissipation. Light engines are IP66 rated. LED lumen maintenance is >L92/100,000 hours. CCT's of 3000K, 4000K and 5000K (minimum 70 CRI) are available. Fixtures ship standard with 0-10v dimming driver. Class 1 electronic drivers ensure system power factor >90% and THD <20%. Easily serviceable 10kV surge protection device meets a minimum Category C Low operation (per ANSI/IEEE C62.41.2).

### STANDARD CONTROLS

The RSX LED area luminaire has a wide assortment of control options. Dusk to dawn controls include MVOLT and 347V button-type photocells and NEMA twist-lock photocell receptacles.

### nLIGHT AIR CONTROLS

The RSX LED area luminaire is also available with nLight® AIR for the ultimate in wireless control. This powerful controls platform provides out-of-the-box basic motion sensing with photocontrol functionality and is suitable for mounting heights up to 40 feet. No commissioning is required when using factory default settings that provide basic stand-alone motion occupancy dimming that is switched on and off with a built-in photocell. See chart above for motion sensor default out-of-box settings. For more advanced wireless functionality, such as group dimming, nLight AIR can be commissioned using a smartphone and the easy-to-use CLAIRITY app. nLight AIR equipped luminaires can be grouped, resulting in motion sensor and photocell group response without the need for additional equipment. Scheduled dimming with motion sensor over-ride can be achieved when used with the nLight Eclipse. Additional information about nLight Air can be found [here](#).

### INSTALLATION

Integral "no-drill" mounting arm allows for fast, easy mounting using existing pole drillings. Select the "SPA" option for square poles and the "RPA" option to mount to round poles. Note, the RPA mount can also be used for mounting to square poles by omitting the RPA adapter plate. Select the "MA" option to attach the luminaire to a 2 3/8" horizontal mast arm or the "IS" option for an adjustable slipfitter that mounts on a 2 3/8" OD tenon. The adjustable slipfitter has an integral junction box and offers easy installation. Can be tilted up to 90° above horizontal. Additional mountings are available including a wall bracket, adjustable tilt arm for direct-to-pole and wall and a surface conduit box for wall mount applications.

### LISTINGS

CSA Certified to meet U.S. and Canadian standards. Suitable for wet locations. Rated for -40°C minimum ambient. DesignLights Consortium® (DLC) Premium qualified product and DLC qualified product. Not all versions of this product may be DLC Premium qualified or DLC qualified. Please check the DLC Qualified Products List at [www.designlights.org/QPL](http://www.designlights.org/QPL) to confirm which versions are qualified.

International Dark-Sky Association (IDA) Fixture Seal of Approval (FSA) is available for all products on this page utilizing 3000K color temperature only. US Patent No. D882, 146S

### BUY AMERICAN ACT

Product with the BAA option is assembled in the USA and meets the Buy America(n) government procurement requirements under FAR, DFARS and DOT regulations.

Please refer to [www.acuitybrands.com/buy-american](http://www.acuitybrands.com/buy-american) for additional information.

### WARRANTY

5-year limited warranty. This is the only warranty provided and no other statements in this specification sheet create any warranty of any kind. All other express and implied warranties are disclaimed. Complete warranty terms located at: [www.acuitybrands.com/support/warranty/terms-and-conditions](http://www.acuitybrands.com/support/warranty/terms-and-conditions)

**Note:** Actual performance may differ as a result of end-user environment and application. All values are design or typical values, measured under laboratory conditions at 25 °C. Specifications subject to change without notice.





## RSX2 LED Area Luminaire



### Specifications

<b>EPA</b> (ft <sup>2</sup> @0°):	0.69 ft <sup>2</sup> (0.06 m <sup>2</sup> )
<b>Length:</b>	29.3" (74.4 cm) (SPA mount)
<b>Width:</b>	13.4" (34.0 cm)
<b>Height:</b>	3.0" (7.6 cm) Main Body 7.2" (18.3 cm) Arm
<b>Weight:</b> (SPA mount)	30.0 lbs (13.6 kg)

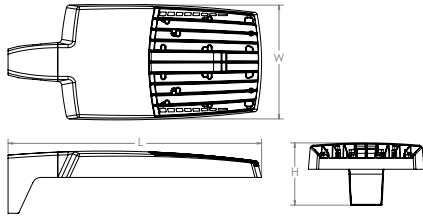

### Introduction

The new RSX LED Area family delivers maximum value by providing significant energy savings, long life and outstanding photometric performance at an affordable price. The RSX2 delivers 11,000 to 31,000 lumens allowing it to replace 250W to 1000W HID luminaires.

The RSX features an integral universal mounting mechanism that allows the luminaire to be mounted on most existing drill hole patterns. This "no-drill" solution provides significant labor savings. An easy-access door on the bottom of mounting arm allows for wiring without opening the electrical compartment. A mast arm adaptor, adjustable integral slipfitter and other mounting configurations are available.



Items marked by a shaded background qualify for the Design Select program and ship in 15 days or less. To learn more about Design Select, visit [www.acuitybrands.com/designselect](http://www.acuitybrands.com/designselect).  
\*See ordering tree for details

 Design Select options indicated by this color background.

### Ordering Information

### EXAMPLE: RSX2 LED P6 40K R3 MVOLT SPA DDBXD

RSX2 LED	P3	40K	R4	MVOLT	SPA
Series	Performance Package	Color Temperature	Distribution	Voltage	Mounting
RSX2 LED	P1 P2 P3 P4 P5 P6	30K 3000K 40K 4000K 50K 5000K	R2 Type 2 Wide R3 Type 3 Wide R3S Type 3 Short R4 Type 4 Wide R4S Type 4 Short R5 Type 5 Wide <sup>1</sup> R5S Type 5 Short <sup>1</sup> AFR Automotive Front Row AFRR90 Automotive Front Row Right Rotated AFRL90 Automotive Front Row Left Rotated	MVOLT (120V-277V) <sup>2</sup> HVOLT (347V-480V) <sup>3</sup> XVOLT (277V-480V) <sup>4</sup>  (use specific voltage for options as noted) 120 <sup>3</sup> 277 <sup>5</sup> 208 <sup>3</sup> 347 <sup>5</sup> 240 <sup>3</sup> 480 <sup>5</sup>	SPA Square pole mounting (3.0" min. SQ pole for 1 at 90°, 3.5" min. SQ pole for 2, 3, 4 at 90°) RPA Round pole mounting (3.2" min. dia. RND pole for 2, 3, 4 at 90°, 3.0" min. dia. RND pole for 1 at 90°, 2 at 180°, 3 at 120°) MA Mast arm adaptor (fits 2-3/8" OD horizontal tenon) IS Adjustable slipfitter (fits 2-3/8" OD tenon) <sup>6</sup> WBA Wall bracket <sup>1</sup> WBASC Wall bracket with surface conduit box AASP Adjustable tilt arm square pole mounting <sup>6</sup> AARP Adjustable tilt arm round pole mounting <sup>6</sup> AAWB Adjustable tilt arm with wall bracket <sup>6</sup> AAWSC Adjustable tilt arm wall bracket and surface conduit box <sup>6</sup>

HS	DDBXD
Options	Finish
<b>Shipped Installed</b> HS House-side shield <sup>7</sup> PE Photocontrol, button style <sup>8,9</sup> PER7 Seven-wire twist-lock receptacle only (no controls) <sup>9,10,11</sup> SF Single fuse (120, 277, 347) <sup>5</sup> DF Double fuse (208, 240, 480) <sup>5</sup> SPD20KV 20KV Surge pack (10KV standard) FAO Field adjustable output <sup>9</sup> DMG 0-10V dimming extend out back of housing for external control (control ordered separate) <sup>9</sup> DS Dual switching <sup>8,12</sup>	DDBXD Dark Bronze DBLXD Black DNAXD Natural Aluminum DWHXD White DDBTXD Textured Dark Bronze DBLTXD Textured Black DNATXD Textured Natural Aluminum DWHGXD Textured White
<b>Shipped Installed</b> *Standalone and Networked Sensors/Controls (factory default settings, see table page 9) NLTAIR2 PIRHN nLight AIR generation 2, with Networked, Bi-Level motion/ambient sensor <sup>9,13,14,15</sup> BAA Buy America(n) Act Compliant CCE Coastal Construction <sup>16</sup> *Note: NLTAIR2 PIRHN with nLight Air can be used as a standalone dimming sensor with out-of-box settings or as a wireless networked solution. See factory default settings table. Sensor coverage pattern is affected when luminaire is tilted. <b>Shipped Separately (requires some field assembly)</b> EGS External glare shield <sup>7</sup> EGFV External glare full visor (360° around light aperture) <sup>7</sup> BS Bird spikes <sup>17</sup>	

## Ordering Information

### Accessories

Ordered and shipped separately.

RSX2HS	RSX2 House side shield (includes 2 shields)
RSX2EGS (FINISH) U	External glare shield (specify finish)
RSX2HSAFRR (FINISH) U	RSX2 House side shields for AFR rotated optics (includes 2 shields)
RSX2EGFV (FINISH) U	External glare full visor (specify finish)
RSXRPA (FINISH) U	RSX Universal round pole adaptor plate (specify finish)
RSXWBA (FINISH) U	RSX WBA wall bracket (specify finish) <sup>1</sup>
RSXSCB (FINISH) U	RSX Surface conduit box (specify finish, for use with WBA, WBA not included)
DLL127F 1.5 JU	Photocell -SSL twist-lock (120-277V) <sup>18</sup>
DLL347F 1.5 CUL JU	Photocell -SSL twist-lock (347V) <sup>18</sup>
DLL480F 1.5 CUL JU	Photocell -SSL twist-lock (480V) <sup>18</sup>
DSHORT SBK U	Shorting cap <sup>18</sup>

### NOTES

- Any Type 5 distribution, is not available with WBA.
- MVOLT driver operates on any line voltage from 120-277V (50/60 Hz).
- HVOLT driver operates on any line voltage from 347-480V (50/60 Hz).
- XVOLT driver not available with P1. XVOLT driver operates on any line voltage from 277V-480V (50/60 Hz). XVOLT not available with fusing (SF or DF) and not available with PE.
- Single fuse (SF) requires 120V, 277V or 347V. Double fuse (DF) requires 208V, 240V or 480V.
- Maximum tilt is 90° above horizontal.
- It may be ordered as an accessory.
- Requires MVOLT or 347V.
- Two or more of the following options cannot be combined including PE, DMG, PER7, FAO, DS and NLTAIR2 PIRHN. (Exception: PE and FAO can be combined; also PE and DMG can be combined.)
- Compatible with standard twist-lock photocells for dusk to dawn operation or advanced control nodes that provide 0-10V dimming signals. Wire 4/Wire 5 wired to dimming leads on driver. Wire6/Wire7 capped inside luminaire. Twistlock photocell ordered and shipped

as a separate line item from Acuity Brands Controls. See accessories. Shorting Cap included.

- For units with option PER7, the mounting must be restricted to +/- 45° from horizontal aim per ANSI C136.10-2010.
- DS requires (2) separately switched circuits. DS provides 50/50 fixture operation via (2) different sets of leads using (2) drivers. DS only available with packages P5 and P6.
- Must be ordered with PIRHN.
- Requires MVOLT or HVOLT.
- Must be ordered with NLTAIR2. For additional information on PIRHN visit [here](#).
- CCE option not available with WBA, WBA, AASP, AARP, AAWB, AAWBSC, EGS, EGFV and BS.
- Must be ordered with fixture for factory pre-drilling.
- Requires luminaire to be specified with PER7 option. Ordered and shipped as a separate line item from Acuity Brands Controls.

## External Shields

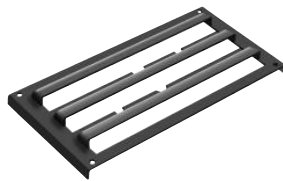

House Side Shield



External Glare Shield



External 360 Full Visor

## Pole/Mounting Information

Accessories including bullhorns, cross arms and other adapters are available under the accessories tab at Lithonia's Outdoor Poles and Arms product page. Click here to visit [Accessories](#).

### HANDHOLE ORIENTATION

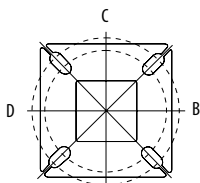

Handhole

### RSX POLE DRILLING

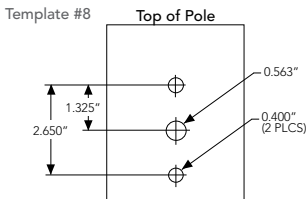

### RSX STANDARD ARM & ADJUSTABLE ARM

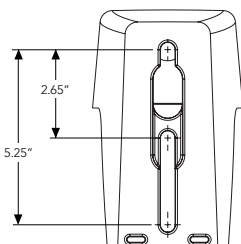

### Round Tenon Mount - Pole Top Slipfitters

Tenon O.D.	RSX Mounting	Single	2 at 180°	2 at 90°	3 at 120°	3 at 90°	4 at 90°
2 - 3/8"	RPA, AARP	AS3-5 190	AS3-5 280	AS3-5 290	AS3-5 320	AS3-5 390	AS3-5 490
2 - 7/8"	RPA, AARP	AST25-190	AST25-280	AST25-290	AST25-320	AST25-390	AST25-490
4"	RPA, AARP	AST35-190	AST35-280	AST35-290	AST35-320	AST35-390	AST35-490

### Drill/Side Location by Configuration Type

Drilling Template	Mounting Option	Single	2 @ 180	2 @ 90	3 @ 120	3 @ 90	4 @ 90
	Head Location	Side B	Side B & D	Side B & C	Round Pole Only	Side B, C & D	Side A, B, C & D
#8	Drill Nomenclature	DM19AS	DM28AS	DM29AS	DM32AS	DM39AS	DM49AS

### RSX2 - Luminaire EPA

\*Includes luminaire and integral mounting arm. Other tenons, arms, brackets or other accessories are not included in this EPA data.

Fixture Quantity & Mounting Configuration	Single	2 @ 90	2 @ 180	3 @ 90	3 @ 120	4 @ 90	2 Side by Side	3 Side by Side	4 Side by Side	
SPA - Square Pole Adaptor	0.69	1.22	1.27	1.8	1.61	2.39	1.37	2.06	2.74	
RPA - Round Pole Adaptor	0.74	1.27	1.37	1.9	1.71	2.49	1.42	2.16	2.84	
MA - Mast Arm Adaptor	0.61	1.14	1.11	1.64	1.45	2.23	1.29	1.9	2.58	
IS - Integral Slipfitter AASP/AARP - Adjustable Arm Square/Round Pole	0°	0.69	1.22	1.27	1.8	1.61	2.39	1.37	2.06	2.74
	10°	0.53	1.06	1.05	1.58	1.37	2.08	1.06	1.59	2.12
	20°	0.52	1.02	1.03	1.52	1.33	2.02	1.03	1.55	2.07
	30°	0.64	1.11	1.18	1.63	1.45	2.21	1.27	1.91	2.54
	40°	0.81	1.21	1.35	1.74	1.65	2.39	1.62	2.43	3.23
	45°	0.91	1.25	1.5	1.81	1.75	2.48	1.82	2.73	3.64
	50°	1.34	1.83	2.17	2.61	2.56	3.62	2.68	4.02	5.36
	60°	2.2	2.97	3.57	4.24	4.17	5.89	4.41	6.61	8.82
	70°	2.86	4.13	4.7	5.89	5.71	8.21	5.71	8.57	11.42
	80°	3.4	5.13	5.67	7.34	7.09	10.21	6.79	10.19	13.59
	90°	3.85	5.96	6.55	8.58	8.31	11.88	7.70	11.56	15.41

## Photometric Diagrams

To see complete photometric reports or download .ies files for this product, visit Lithonia Lighting's RSX Area homepage.

Isofootcandle plots for the RSX2 LED P6 40K. Distances are in units of mounting height (30').

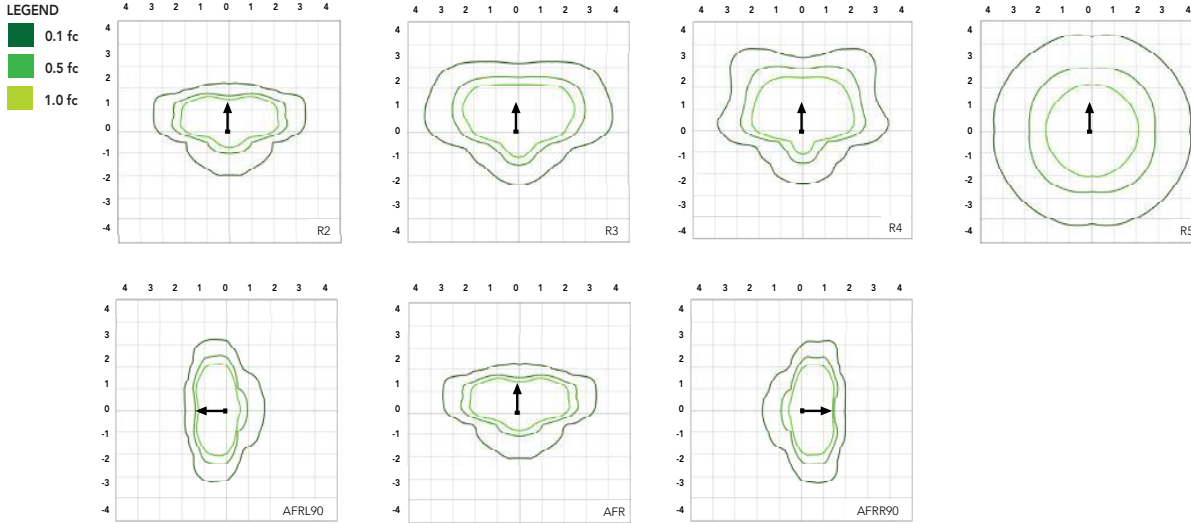

## Performance Data

### Lumen Ambient Temperature (LAT) Multipliers

Use these factors to determine relative lumen output for average ambient temperatures from 0-50°C (32-122°F).

Ambient	Ambient	Lumen Multiplier
0°C	32°F	1.05
5°C	41°F	1.04
10°C	50°F	1.03
15°C	59°F	1.02
20°C	68°F	1.01
25°C	77°F	1.00
30°C	86°F	0.99
35°C	95°F	0.98
40°C	104°F	0.97
45°C	113°F	0.96
50°C	122°F	0.95

### Electrical Load

Performance Package	System Watts (W)	Current (A)					
		120V	208V	240V	277V	347V	480V
P1	71W	0.59	0.34	0.30	0.26	0.20	0.15
P2	111W	0.93	0.53	0.46	0.40	0.32	0.23
P3	147W	1.23	0.70	0.61	0.53	0.42	0.31
P4	187W	1.55	0.90	0.78	0.68	0.53	0.38
P5	210W	1.75	1.01	0.87	0.76	0.60	0.44
P6	244W	2.03	1.17	1.01	0.88	0.70	0.51

### Projected LED Lumen Maintenance

Operating Hours	50,000	75,000	100,000
Lumen Maintenance Factor	>0.97	>0.95	>0.92

Values calculated according to IESNA TM-21-11 methodology and valid up to 40°C.



Project 22-73934-21  
Scrubbles Car Wash ~ Blanket for 4 locations

Submitted By  
ST. LOUIS LIGHTING GROUP

Catalog Number: RSX2 LED P3 40K R4 MVOLT HS SPA  
DDBXD

Note:

Type  
A2B-T4W-HSS

## Performance Data

### Lumen Output

Lumen values are from photometric tests performed in accordance with IESNA LM-79-08. Data is considered to be representative of the configurations shown, within the tolerances allowed by Lighting Facts. Contact factory for performance data on any configurations not shown here.

Performance Package	System Watts	Distribution Type	30K (3000K, 70 CRI)					40K (4000K, 70 CRI)					50K (5000K, 70 CRI)				
			Lumens	B	U	G	LPW	Lumens	B	U	G	LPW	Lumens	B	U	G	LPW
P1	71W	R2	10,040	2	0	1	139	11,031	2	0	1	153	11,031	2	0	1	153
		R3	10,005	2	0	2	141	10,992	2	0	2	155	10,992	2	0	2	155
		R3S	10,271	2	0	2	143	11,285	2	0	2	157	11,285	2	0	2	157
		R4	10,136	2	0	2	143	11,136	2	0	2	157	11,136	2	0	2	157
		R4S	9,779	2	0	2	138	10,744	2	0	2	151	10,744	2	0	2	151
		R5	10,271	4	0	2	145	11,285	4	0	2	159	11,285	4	0	2	159
		R5S	10,544	3	0	1	149	11,585	3	0	2	163	11,585	3	0	2	163
		AFR	10,026	2	0	1	141	11,016	2	0	1	155	11,016	2	0	1	155
		AFRR90	10,122	3	0	2	140	11,121	3	0	2	154	11,121	3	0	2	154
		AFRL90	10,164	3	0	2	141	11,167	3	0	2	155	11,167	3	0	2	155
		R2	15,712	2	0	2	138	17,263	2	0	2	151	17,263	2	0	2	151
		R3	15,657	2	0	3	141	17,202	3	0	3	155	17,202	3	0	3	155
R3S	16,075	2	0	2	141	17,661	2	0	2	155	17,661	2	0	2	155		
R4	15,862	2	0	3	143	17,427	2	0	3	157	17,427	2	0	3	157		
R4S	15,304	2	0	2	138	16,815	2	0	2	151	16,815	2	0	2	151		
R5	16,075	4	0	2	145	17,661	5	0	3	159	17,661	5	0	3	159		
R5S	16,502	4	0	2	149	18,130	4	0	2	163	18,130	4	0	2	163		
AFR	15,691	2	0	2	141	17,240	2	0	2	155	17,240	2	0	2	155		
AFRR90	15,841	3	0	3	139	17,404	4	0	3	153	17,404	4	0	3	153		
AFRL90	15,907	3	0	3	139	17,477	4	0	3	153	17,477	4	0	3	153		
R2	19,855	3	0	2	132	21,814	3	0	2	145	21,814	3	0	2	145		
R3	19,785	3	0	3	135	21,737	3	0	4	148	21,737	3	0	4	148		
R3S	20,312	3	0	3	135	22,317	3	0	3	149	22,317	3	0	3	149		
R4	20,044	3	0	3	136	22,022	3	0	4	150	22,022	3	0	4	150		
R4S	19,339	3	0	3	132	21,247	3	0	3	145	21,247	3	0	3	145		
R5	20,313	5	0	3	138	22,317	5	0	3	152	22,317	5	0	3	152		
R5S	20,852	4	0	2	142	22,910	4	0	2	156	22,910	4	0	2	156		
AFR	19,828	3	0	2	135	21,785	3	0	2	148	21,785	3	0	2	148		
AFRR90	20,017	4	0	3	133	21,992	4	0	3	147	21,992	4	0	3	147		
AFRL90	20,101	4	0	3	134	22,084	4	0	3	147	22,084	4	0	3	147		
R2	22,836	3	0	2	120	25,090	3	0	2	132	25,090	3	0	2	132		
R3	22,756	3	0	4	122	25,002	3	0	4	134	25,002	3	0	4	134		
R3S	23,363	3	0	3	123	25,668	3	0	3	135	25,668	3	0	3	135		
R4	23,054	3	0	4	123	25,329	3	0	4	135	25,329	3	0	4	135		
R4S	22,243	3	0	3	119	25,059	3	0	3	134	25,059	3	0	3	134		
R5	23,363	5	0	3	125	25,669	5	0	4	137	25,669	5	0	4	137		
R5S	23,983	4	0	2	128	26,350	4	0	2	141	26,350	4	0	2	141		
AFR	22,806	3	0	2	122	25,056	3	0	2	134	25,056	3	0	2	134		
AFRR90	23,023	4	0	3	121	25,295	4	0	3	133	25,295	4	0	3	133		
AFRL90	23,120	4	0	3	122	25,401	4	0	3	134	25,401	4	0	3	134		
R2	26,141	3	0	2	122	28,721	3	0	2	135	28,721	3	0	2	135		
R3	26,049	3	0	4	124	28,620	3	0	4	136	28,620	3	0	4	136		
R3S	26,744	3	0	3	125	29,383	3	0	4	138	29,383	3	0	4	138		
R4	26,390	3	0	4	126	28,994	3	0	4	138	28,994	3	0	4	138		
R4S	25,462	3	0	3	121	27,974	3	0	3	133	27,974	3	0	3	133		
R5	26,744	5	0	4	127	29,383	5	0	4	140	29,383	5	0	4	140		
R5S	27,454	4	0	2	131	30,163	4	0	2	144	30,163	4	0	2	144		
AFR	26,106	3	0	2	124	28,682	3	0	2	137	28,682	3	0	2	137		
AFRR90	26,354	4	0	3	123	28,955	5	0	3	136	28,955	5	0	3	136		
AFRL90	26,465	4	0	3	124	29,077	5	0	3	136	29,077	5	0	3	136		
R2	27,646	3	0	2	112	30,374	3	0	2	123	30,374	3	0	2	123		
R3	27,549	3	0	4	113	30,267	3	0	4	124	30,267	3	0	4	124		
R3S	28,283	3	0	3	115	31,075	3	0	4	126	31,075	3	0	4	126		
R4	27,909	3	0	4	114	30,663	3	0	4	126	30,663	3	0	4	126		
R4S	26,928	3	0	3	110	29,585	3	0	3	121	29,585	3	0	3	121		
R5	28,284	5	0	4	116	31,075	5	0	4	127	31,075	5	0	4	127		
R5S	29,035	4	0	2	119	31,900	5	0	3	131	31,900	5	0	3	131		
AFR	27,608	3	0	2	112	30,332	3	0	2	123	30,332	3	0	2	123		
AFRR90	27,872	4	0	3	113	30,622	5	0	3	124	30,622	5	0	3	124		
AFRL90	27,989	4	0	3	113	30,751	5	0	3	125	30,751	5	0	3	125		



## Dimensions & Weights

### Luminaire Weight by Mounting Type

Mounting Configuration	Total Luminaire Weight
SPA	30 lbs
RPA	32 lbs
MA	30 lbs
WBA	33 lbs
WBASC	36 lbs
IS	33 lbs
AASP	33 lbs
AARP	35 lbs
AAWB	36 lbs
AAWSC	39 lbs

### RSX2 with Round Pole Adapter (RPA)

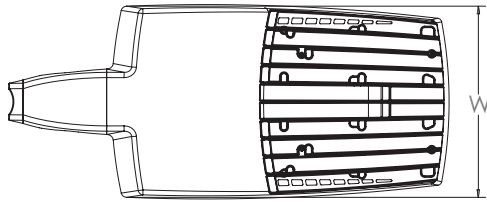

Length: 30.3" (77.0 cm)  
Width: 13.4" (34.0 cm)  
Height: 3.0" (7.6 cm) Main Body  
7.2" (18.3 cm) Arm

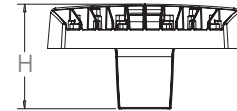
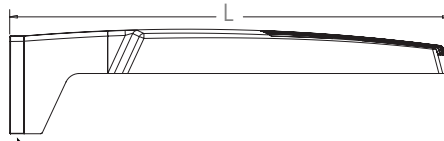

Note: RPA — Round Pole mount can also be used to mount on square poles by omitting the round pole adapter plate shown here.



### RSX2 with Mast Arm Adapter (MA)

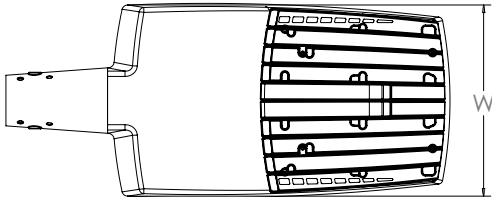

Length: 30.6" (77.7 cm)  
Width: 13.4" (34.0 cm)  
Height: 3.0" (7.6 cm) Main Body  
3.5" (8.9 cm) Arm

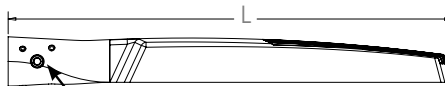

7/16" locking thru bolt/nut provided



### RSX2 with Adjustable Slipfitter (IS)

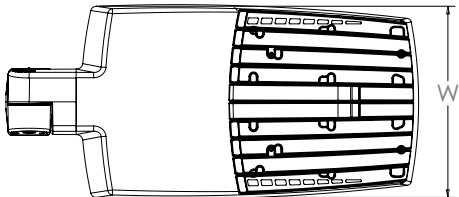

Length: 28.3" (71.9 cm)  
Width: 13.4" (34.0 cm)  
Height: 3.0" (7.6 cm) Main Body  
7.6" (19.3 cm) Arm

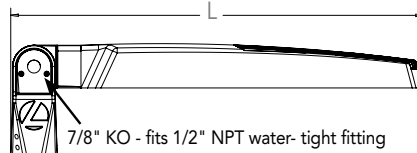

7/8" KO - fits 1/2" NPT water-tight fitting

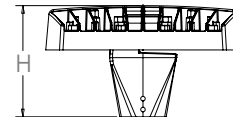

## Dimensions

### RSX2 with Wall Bracket (WBA)

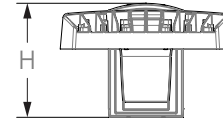
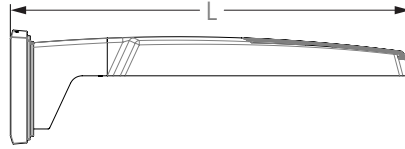
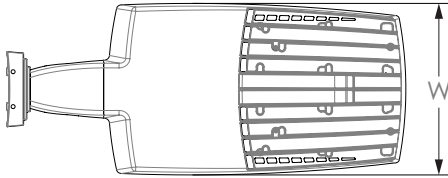

Length: 31.2" (79.2 cm)  
Width: 13.4" (41.7 cm)  
Height: 3.0" (7.6 cm) Main Body  
8.9" (22.6 cm) Arm

### Wall Bracket (WBA) Mounting Detail

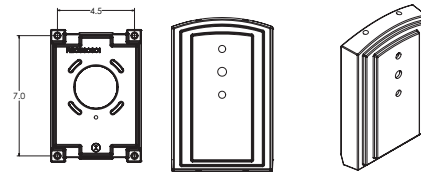

### RSX2 with Wall Bracket with Surface Conduit Box (WBASC)

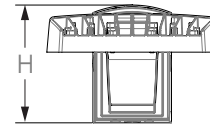
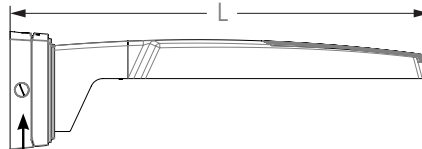
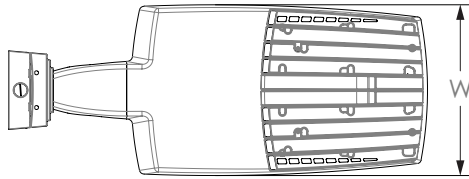

3/4" NPT taps with plugs - Qty (4) provided

Length: 32.8" (83.3 cm)  
Width: 13.4" (41.7 cm)  
Height: 3.0" (7.6 cm) Main Body  
9.2" (23.4 cm) Arm

### Surface Conduit Box (SCB) Mounting Detail

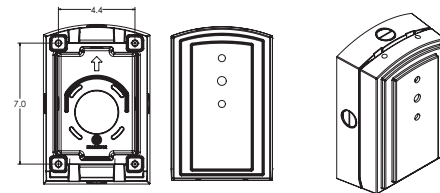



## Dimensions

### RSX2 with Adjustable Tilt Arm - Square or Round Pole (AASP or AARP)

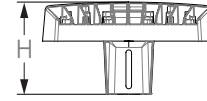
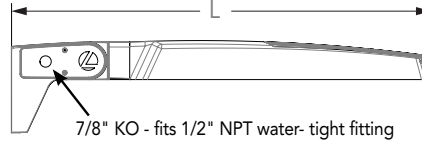
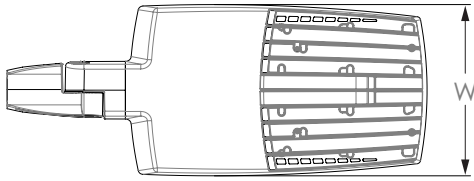

Length: 32.8" (83.3 cm) AASP  
33.8" (85.9 cm) AARP  
Width: 13.4" (34.0 cm)  
Height: 3.0" (7.6 cm) Main Body  
7.2" (18.2 cm) Arm

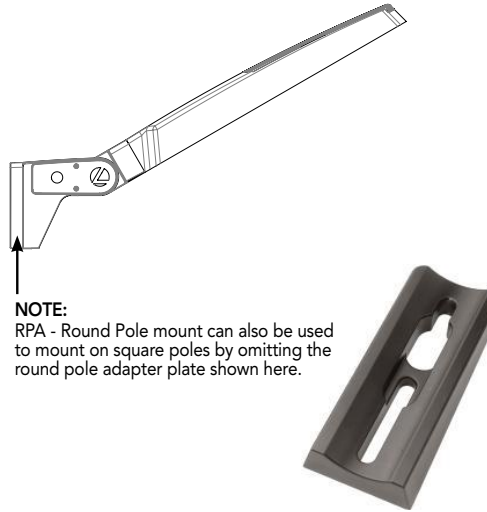

**NOTE:**  
RPA - Round Pole mount can also be used to mount on square poles by omitting the round pole adapter plate shown here.

**Notes**  
AASP: Requires 3.0" min. square pole for 1 at 90°. Requires 3.5" min. square pole for mounting 2, 3, 4 at 90°.  
AARP: Requires 3.2" min. dia. round pole for 2, 3, 4 at 90°. Requires 3.0" min. dia. round pole for mounting 1 at 90°, 2 at 180°, 3 at 120°.

### RSX2 with Adjustable Tilt Arm with Wall Bracket (AAWB)

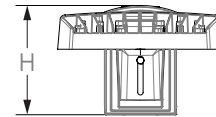
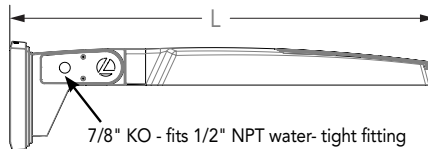
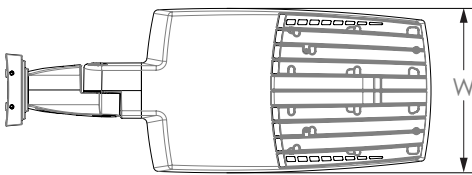

Length: 34.7" (88.0 cm)  
Width: 13.4" (34.0 cm)  
Height: 3.0" (7.6 cm) Main Body  
8.9" (22.6 cm) Arm

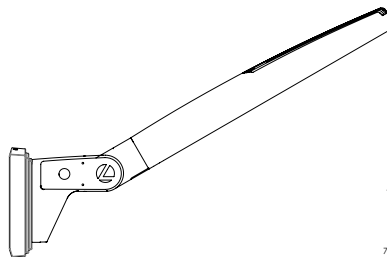

#### Wall Bracket (WBA) Mounting Detail

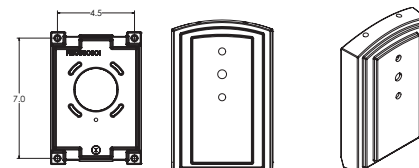

## Dimensions

### RSX2 with Adjustable Tilt Arm with Wall Bracket and Surface Conduit Box (AAWSC)

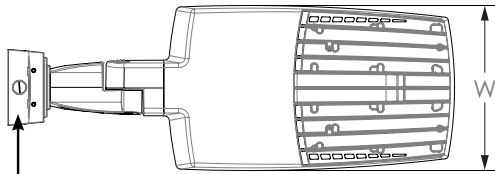

3/4" NPT taps  
with plugs - Qty (4)  
provided

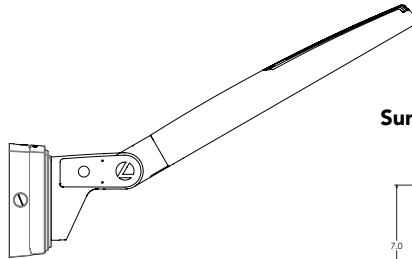
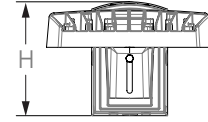
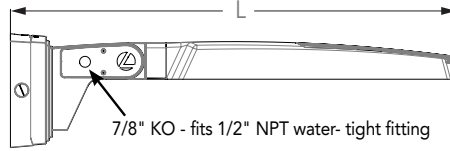

Length: 36.2" (91.9 cm)  
Width: 13.4" (40.0 cm)  
Height: 3.0" (7.6 cm) Main Body  
9.2" (23.4 cm) Arm

### Surface Conduit Box (SCB) Mounting Detail

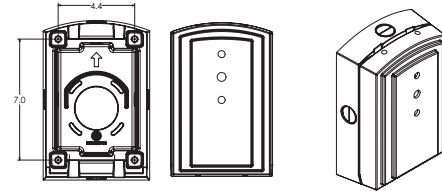

### Automotive Front Row - Rotated Optics (AFRL90/R90)

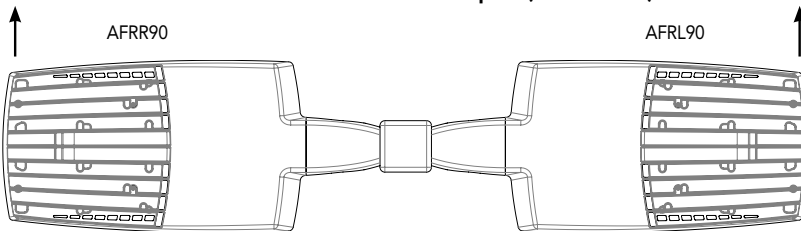

(Example: 2@180 - arrows indicate direction of light exiting the luminaire)

## nLight Control - Sensor Coverage and Settings

### NLTAIR2 PIRHN nLight Sensor Coverage Pattern nLight PIRHN

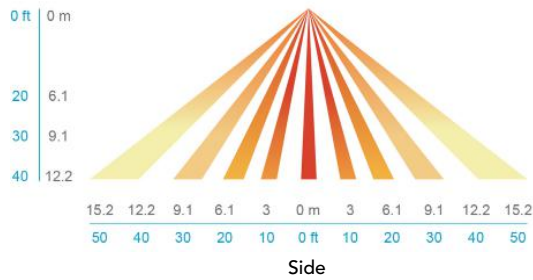
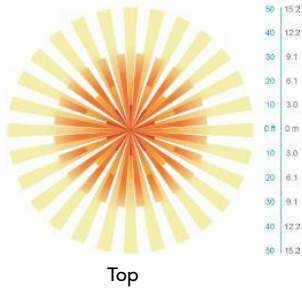
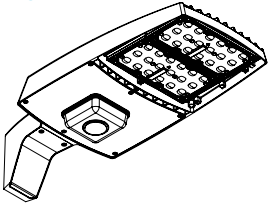

Motion Sensor Default Settings - Option PIRHN						
Option	Dimmed State (unoccupied)	High Level (when occupied)	Photocell Operation	Dwell Time (occupancy time delay)	Ramp-up Time (from unoccupied to occupied)	Ramp-down Time (from occupied to unoccupied)
NLTAIR2 PIRHN	Approx. 30% Output	100% Output	Enabled @ 1.5FC	7.5 minutes	3 seconds	5 minutes

\*Note: NLTAIR2 PIRHN default settings including photocell set-point, high/low dim rates, and occupancy sensor time delay are all configurable using the Clairity Pro App. Sensor coverage pattern shown with luminaire at 0°. Sensor coverage pattern is affected when luminaire is tilted.

## FEATURES & SPECIFICATIONS

### INTENDED USE

The RSX LED area family is designed to provide a long-lasting, energy-efficient solution for the one-for-one replacement of existing metal halide or high pressure sodium lighting. The RSX2 delivers 11,000 to 31,000 lumens and is ideal for replacing 250W to 1000W HID pole-mounted luminaires in parking lots and other area lighting applications.

### CONSTRUCTION AND DESIGN

The RSX LED area luminaire features a rugged die-cast aluminum main body that uses heat-dissipating fins and flow-through venting to provide optimal thermal management that both enhances LED performance and extends component life. Integral "no drill" mounting arm allows the luminaire to be mounted on existing pole drillings, greatly reducing installation labor. The light engines and housing are sealed against moisture and environmental contaminants to IP66. The low-profile design results in a low EPA, allowing pole optimization. Vibration rated per ANSI C136.31; 3G Mountings: Include SPA, RPA, MA, IS, AASP, AARP rated for 3G vibration. 1.5G Mountings: Include WBA, WBASC, AAWB and AAWSC rated for 1.5G vibration.

### FINISH

Exterior parts are protected by a zinc-infused Super Durable TGIC thermoset powder coat finish that provides superior resistance to corrosion and weathering. A tightly controlled multi-stage process ensures superior adhesion as well as a minimum finish thickness of 3 mils. The result is a high-quality finish that is warranted not to crack or peel.

### OPTICS

Precision acrylic refractive lenses are engineered for superior application efficiency, distributing the light to where it is needed most. Available in short and wide pattern distributions including Type 2, Type 3, Type 3S, Type 4, Type 4S, Type 5, Type 5S, AFR (Automotive Front Row) and AFR rotated AFRR90 and ARFL90.

### COASTAL CONSTRUCTION (CCE)

Optional corrosion resistant construction is engineered with added corrosion protection in materials and/or pre-treatment of base material under super durable paint. Provides additional corrosion protection for applications near coastal areas. Finish is salt spray tested to over 5,000 hours per ASTM B117 with scribe rating of 10. Additional lead-times apply.

### ELECTRICAL

Light engine(s) configurations consist of high-efficacy LEDs mounted on metal-core circuit boards and aluminum heat sinks to maximize heat dissipation. Light engines are IP66 rated. LED lumen maintenance is >L92/100,000 hours. CCT's of 3000K, 4000K and 5000K (minimum 70 CRI) are available. Fixtures ship standard with 0-10v dimming driver. Class 1 electronic drivers ensure system power factor >90% and THD <20%. Easily serviceable 10kV surge protection device meets a minimum Category C Low operation (per ANSI/IEEE C62.41.2).

### STANDARD CONTROLS

The RSX LED area luminaire has a wide assortment of control options. Dusk to dawn controls include MVOLT and 347V button-type photocells and NEMA twist-lock photocell receptacles.

### nLIGHT AIR CONTROLS

The RSX LED area luminaire is also available with nLight® AIR for the ultimate in wireless control. This powerful controls platform provides out-of-the-box basic motion sensing with photocontrol functionality and is suitable for mounting heights up to 40 feet. No commissioning is required when using factory default settings that provide basic stand-alone motion occupancy dimming that is switched on and off with a built-in photocell. See chart above for motion sensor default out-of-box settings. For more advanced wireless functionality, such as group dimming, nLight AIR can be commissioned using a smartphone and the easy-to-use CLAIRITY app. nLight AIR equipped luminaires can be grouped, resulting in motion sensor and photocell group response without the need for additional equipment. Scheduled dimming with motion sensor over-ride can be achieved when used with the nLight Eclipse. Additional information about nLight Air can be found [here](#).

### INSTALLATION

Integral "no-drill" mounting arm allows for fast, easy mounting using existing pole drillings. Select the "SPA" option for square poles and the "RPA" option to mount to round poles. Note, the RPA mount can also be used for mounting to square poles by omitting the RPA adapter plate. Select the "MA" option to attach the luminaire to a 2 3/8" horizontal mast arm or the "IS" option for an adjustable slipfitter that mounts on a 2 3/8" OD tenon. The adjustable slipfitter has an integral junction box and offers easy installation. Can be tilted up to 90° above horizontal. Additional mountings are available including a wall bracket, adjustable tilt arm for direct-to-pole and wall and a surface conduit box for wall mount applications.

### LISTINGS

CSA Certified to meet U.S. and Canadian standards. Suitable for wet locations. Rated for -40°C minimum ambient. DesignLights Consortium® (DLC) Premium qualified product and DLC qualified product. Not all versions of this product may be DLC Premium qualified or DLC qualified. Please check the DLC Qualified Products List at [www.designlights.org/QPL](http://www.designlights.org/QPL) to confirm which versions are qualified.

International Dark-Sky Association (IDA) Fixture Seal of Approval (FSA) is available for all products on this page utilizing 3000K color temperature only. US Patent No. D882, 146S

### BUY AMERICAN ACT

Product with the BAA option is assembled in the USA and meets the Buy America(n) government procurement requirements under FAR, DFARS and DOT regulations. Please refer to [www.acuitybrands.com/buy-american](http://www.acuitybrands.com/buy-american) for additional information.

### WARRANTY

5-year limited warranty. This is the only warranty provided and no other statements in this specification sheet create any warranty of any kind. All other express and implied warranties are disclaimed. Complete warranty terms located at: [www.acuitybrands.com/support/warranty/terms-and-conditions](http://www.acuitybrands.com/support/warranty/terms-and-conditions)

**Note:** Actual performance may differ as a result of end-user environment and application. All values are design or typical values, measured under laboratory conditions at 25 °C. Specifications subject to change without notice.



Project 22-73934-21  
Scrubbles Car Wash ~ Blanket for 4 locations

Submitted By  
ST. LOUIS LIGHTING GROUP

Catalog Number: SSS 20 4C DM19AS DDBXD

Note:

Type  
**POLES**



## FEATURES & SPECIFICATIONS

**INTENDED USE** — These specifications are for USA standards only. Square Straight Steel is a general purpose light pole for up to 39-foot mounting heights. This pole provides a robust yet cost effective option for mounting area lights and floodlights.

### CONSTRUCTION

**Pole Shaft:** The pole shaft is of uniform dimension and wall thickness and is made of a weldable-grade, hot-rolled, commercial-quality steel tubing with a minimum yield of 55 KSI (11-gauge, 0.120"), or 50 KSI (7-gauge, 0.179"). Shaft is one-piece with a full-length longitudinal high-frequency electric resistance weld. Uniformly square in cross-section with flat sides, small corner radii and excellent torsional qualities. Available shaft widths are 4", 5" and 6".

**Pole Top:** Options include 4" tenon top, drilled for side mount fixture, tenon with drilling (includes extra handhole) and open top. Side drilled and open top poles include a removable top cap.

**Handhole:** A reinforced handhole with grounding provision is provided at 18" from the base on side A. Positioning the handhole lower may not be possible and requires engineering review; consult Tech Support-Outdoor for further information. Every handhole includes a cover and cover attachment hardware. The handhole has a nominal dimension of 2.5" x 5".

**Base Cover:** A durable ABS plastic two-piece full base cover, finished to match the pole, is provided with each pole assembly. Additional base cover options are available upon request.

**Anchor Base/Bolts:** Anchor base is fabricated from steel that meets ASTM A36 standards and can be altered to match existing foundations; consult factory for modifications. Anchor bolts are manufactured to ASTM F1554 Standards grade 55, (55 KSI minimum yield strength and tensile strength of 75-95 KSI). Top threaded portion (nominal 12") is hot-dipped galvanized per ASTM A-153.

**HARDWARE** — All structural fasteners are high-strength galvanized carbon steel. All non-structural fasteners are galvanized or zinc-plated carbon steel or stainless steel.

**FINISH** — Extra durable painted finish is coated with TGIC (Triglycidyl Isocyanurate) Polyester powder that meets 5A and 5B classifications of ASTM D3359. Powder-coat finishes include Dark Bronze, White, Black, and Natural Aluminum colors. Architectural Colors and Special Finishes are available by quote and include, but are not limited to Paint over Hot-dipped Galvanized, RAL Colors, Custom Colors and Extended Warranty Finishes.

**BUY AMERICAN ACT** — Product with the BAA option is assembled in the USA and meets the Buy America(n) government procurement requirements under FAR, DFARS and DOT regulations. Please refer to [www.acuitybrands.com/buy-american](http://www.acuitybrands.com/buy-american) for additional information.

**INSTALLATION** — Do not erect poles without having fixtures installed. Factory-supplied templates must be used when setting anchor bolts. Lithonia Lighting will not accept claim for incorrect anchorage placement due to failure to use Lithonia Lighting factory templates. If poles are stored outside, all protective wrapping must be removed immediately upon delivery to prevent finish damage. Lithonia Lighting is not responsible for the foundation design.

**WARRANTY** — 1-year limited warranty. This is the only warranty provided and no other statements in this specification sheet create any warranty of any kind. All other express and implied warranties are disclaimed. Complete warranty terms located at: [www.acuitybrands.com/support/warranty/terms-and-conditions](http://www.acuitybrands.com/support/warranty/terms-and-conditions)

**NOTE:** Actual performance may differ as a result of end-user environment and application. Specifications subject to change without notice.

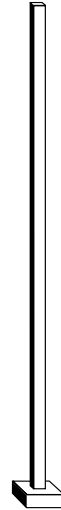

Anchor Base Poles

# SSS

SQUARE STRAIGHT STEEL





Project 22-73934-21  
Scrubbles Car Wash ~ Blanket for 4 locations

Submitted By  
ST. LOUIS LIGHTING GROUP

Catalog Number: SSS 20 4C DM19AS DDBXD

Note:

Type  
**POLES**

## SSS Square Straight Steel Poles

**ORDERING INFORMATION** Lead times will vary depending on options selected. Consult with your sales representative. **Example: SSS 20 5C DM19 DDBXD**

SSS	20	4C	DM19AS		DDBXD	
Series	Nominal fixture mounting height	Nominal shaft base size/wall thickness <sup>2</sup>	Mounting <sup>3</sup>	Options	Finish <sup>4</sup>	
SSS <sup>1</sup>	10'-39' (for 1/2 ft increments, add -6 to the pole height. Ex: 20-6 equals 20ft 6in.)  See technical information table for complete ordering information.)	4C 4" 11g (0.120") 4G 4" 7g (0.179") 5C 5" 11g (0.120") 5G 5" 7g (0.179") 6G 6" 7g (0.179")  See technical information table for complete ordering information.)	<b>Tenon mounting</b> PT Open top (includes top cap) T20 2-3/8" O.D. (2" NPS) T25 2-7/8" O.D. (2-1/2" NPS) T30 3-1/2" O.D. (3" NPS) T35 4" O.D. (3-1/2" NPS) <b>KAC/KAD/KSE/KSF/KVR/KVF Drill mounting<sup>4</sup></b> DM19 1 at 90° DM28 2 at 180° DM28 PL 2 at 180° with one side plugged DM29 2 at 90° DM39 3 at 90° DM49 4 at 90° <b>CSX/DSX/RXS/AERIS™/OMERO™/HLA/KAX Drill mounting<sup>4</sup></b> DM19AS 1 at 90° DM28AS 2 at 180° DM29AS 2 at 90° DM39AS 3 at 90° DM49AS 4 at 90° <b>RAD drill mounting<sup>4,5</sup></b> DM19RAD 1 at 90° DM28RAD 2 at 180° DM29RAD 2 at 90° DM39RAD 3 at 90° DM49RAD 4 at 90° <b>ESX Drill mounting<sup>4</sup></b> DM19ESX 1 at 90° DM28ESX 2 at 180° DM29ESX 2 at 90° DM39ESX 3 at 90° DM49ESX 4 at 90°	<b>AERIS™ Suspend drill mounting<sup>4,6</sup></b> DM19AST_ 1 at 90° DM28AST_ 2 at 180° DM29AST_ 2 at 90° DM39AST_ 3 at 90° DM49AST_ 4 at 90° <b>OMERO™ Suspend drill mounting<sup>4,6</sup></b> DM19MRT_ 1 at 90° DM28MRT_ 2 at 180° DM29MRT_ 2 at 90° DM39MRT_ 3 at 90° DM49MRT_ 4 at 90°	<b>Shipped installed</b> VD Vibration damper <sup>7</sup> HAXy Horizontal arm bracket (1 fixture) <sup>8,9</sup> FDLxy Festoon outlet less electrical <sup>8,10</sup> CPL12/xy 1/2" coupling <sup>8</sup> CPL34/xy 3/4" coupling <sup>8</sup> CPL1/xy 1" coupling <sup>8</sup> NPL12/xy 1/2" threaded nipple <sup>8</sup> NPL34/xy 3/4" threaded nipple <sup>8</sup> NPL1/xy 1" threaded nipple <sup>8</sup> EHHxy Extra handhole <sup>8,11</sup>  STLHHC Steel handhole cover (standard is plastic, finish is smooth) FBCSTL2PC 2 Piece steel base cover (standard is plastic)  IC Interior coating <sup>12</sup> L/AB Less anchor bolts (Include when anchor bolts are not needed)  TP Tamper resistant handhole cover fasteners  NEC NEC 410.30 compliant gasketed handhole (Not UL Labeled)  UL UL listed with label (Includes NEC compliant cover)  BAA Buy America(n) Act Compliant <sup>13</sup>	<b>Super durable paint colors</b> DDBXD Dark bronze DBLXD Black DNAXD Natural aluminum DWHXD White DSSXD Sandstone DGCXD Charcoal gray DTGXD Tennis green DBRXD Bright red DSBXD Steel blue DDBTXD Textured dark bronze DBLBXD Textured black DNATXD Textured natural aluminum DWHGXD Textured white <b>Other finishes</b> GALV Galvanized finish <b>Architectural colors and special finishes</b> Paint over Galvanized, RAL Colors, Custom Colors and Extended Warranty Finishes available.

### NOTES:

- Handhole covers (HHC), full base covers (FBC) and top caps (TC) shipped separately. No need to call out in nomenclature. For additional parts please order as replacements.
- Wall thickness will be signified with a "C" (11 Gauge) or a "G" (7-Gauge) in nomenclature. "C" - 0.120" | "G" - 0.179".
- PT open top poles include top cap. When ordering tenon mounting and drill mounting for the same pole, follow this example: DM28/T20. The combination includes a required extra handhole.
- Refer to the fixture spec sheet for the correct drilling template pattern and orientation compatibility.
- All RAD drilling's require a minimum top O.D. of 4".
- Insert "1" or "2" to designate fixture size; e.g. DM19AST2.
- On 4" and 5" poles, VD cannot be installed if provisions (EHH, FDL, NPL, CPL) are located higher than 2/3 of the pole's total height.  
Example: Pole height is 25ft. A provision cannot be placed above 16ft.
- Specify location and orientation when ordering option.  
**For "x":** Specify the height above the base of pole in feet or feet and inches; separate feet and inches with a "-".  
Example: 5ft = 5 and 20ft 3in = 20-3  
**For "y":** Specify orientation from handhole (A,B,C,D) Refer to the Handhole Orientation diagram below.  
Example: 1/2" coupling at 5' 8"; orientation C = CPL12/5-8C
- Horizontal arm is 18" x 2-3/8" O.D. tenon standard, with radius curve providing 12" rise and 2-3/8" O.D. If ordering two horizontal arm at the same height, specify with HAXxy. Example: HA20BD.
- FDL does not come with GFCI outlet or handhole cover. These must be supplied by contractor or electrician.
- Combination of tenon-top and drill mount includes extra handhole. EHH includes cover.
- Provides enhanced corrosion resistance.
- Use when mill certifications are required.
- Finish must be specified. Additional colors available; see Architectural Colors brochure linked [here](#) (Form No. 794.3). Lead times may be extended up to 2 weeks due to paint procurement.

<b>Accessories: Order as separate catalog number.</b>	
PL DT20	Plugs for ESX drillings
PL DT8	Plugs for DMxxAS drillings



Project 22-73934-21  
Scrubbles Car Wash ~ Blanket for 4 locations

Submitted By  
ST. LOUIS LIGHTING GROUP

Catalog Number: SSS 20 4C DM19AS DDBXD

Note:

Type  
**POLES**

## SSS Square Straight Steel Poles

TECHNICAL INFORMATION — EPA (ft <sup>2</sup> ) with 1.3 gust													
Catalog Number	Nominal Shaft Length (ft.)*	Pole Shaft Size (Base in. x Top in. x ft.)	Wall thick (in)	Gauge	EPA (ft <sup>2</sup> ) with 1.3 gust						Bolt circle (in)	Bolt size (in. x in. x in.)	Approximate ship weight (lbs.)
					80 MPH	Max. weight	90 MPH	Max. weight	100 MPH	Max. weight			
SSS 10 4C	10	4.0 x 10.0	0.120"	11	30.6	765	23.8	595	18.9	473	8-9	3/4 x 18 x 3	75
SSS 12 4C	12	4.0 x 12.0	0.120"	11	24.4	610	18.8	470	14.8	370	8-9	3/4 x 18 x 3	90
SSS 14 4C	14	4.0 x 14.0	0.120"	11	19.9	498	15.1	378	11.7	293	8-9	3/4 x 18 x 3	100
SSS 16 4C	16	4.0 x 16.0	0.120"	11	15.9	398	11.8	295	8.9	223	8-9	3/4 x 18 x 3	115
SSS 18 4C	18	4.0 x 18.0	0.120"	11	12.6	315	9.2	230	6.7	168	8-9	3/4 x 18 x 3	125
SSS 20 4C	20	4.0 x 20.0	0.120"	11	9.6	240	6.7	167	4.5	150	8-9	3/4 x 18 x 3	140
SSS 20 4G	20	4.0 x 20.0	0.179"	7	14	350	11	275	8	200	8-9	3/4 x 30 x 3	198
SSS 20 5C	20	5.0 x 20.0	0.120"	11	17.7	443	12.7	343	9.4	235	10-12	1 x 36 x 4	185
SSS 20 5G	20	5.0 x 20.0	0.179"	7	28.1	703	21.4	535	16.2	405	10-12	1 x 36 x 4	265
SSS 25 4C	25	4.0 x 25.0	0.120"	11	4.8	150	2.6	100	1	50	8-9	3/4 x 18 x 3	170
SSS 25 4G	25	4.0 x 25.0	0.179"	7	10.8	270	7.7	188	5.4	135	8-9	3/4 x 30 x 3	245
SSS 25 5C	25	5.0 x 25.0	0.120"	11	9.8	245	6.3	157	3.7	150	10-12	1 x 36 x 4	225
SSS 25 5G	25	5.0 x 25.0	0.179"	7	18.5	463	13.3	333	9.5	238	10-12	1 x 36 x 4	360
SSS 30 4G	30	4.0 x 30.0	0.179"	7	6.7	168	4.4	110	2.6	65	8-9	3/4 x 30 x 3	295
SSS 30 5C	30	5.0 x 30.0	0.120"	11	4.7	150	2	50	--	--	10-12	1 x 36 x 4	265
SSS 30 5G	30	5.0 x 30.0	0.179"	7	10.7	267	6.7	167	3.9	100	10-12	1 x 36 x 4	380
SSS 30 6G	30	6.0 x 30.0	0.179"	7	19	475	13.2	330	9	225	11-13	1 x 36 x 4	520
SSS 35 5G	35	5.0 x 35.0	0.179"	7	5.9	150	2.5	100	--	--	10-12	1 x 36 x 4	440
SSS 35 6G	35	6.0 x 35.0	0.179"	7	12.4	310	7.6	190	4.2	105	11-13	1 x 36 x 4	540
SSS 39 6G	39	6.0 x 39.0	0.179"	7	7.2	180	3	75	--	--	11-13	1 x 36 x 4	605

NOTE: \* EPA values are based ASCE 7-93 wind map. For 1/2 ft increments, add -6 to the pole height. Ex: 20-6 equals 20ft 6in.

TECHNICAL INFORMATION — EPA (ft <sup>2</sup> ) WITH 3-SECOND GUST PER AASHTO 2013																	
Series	Mounting Height (ft)*	Shaft Base Size	90 MPH	Max. weight	100 MPH	Max. weight	110 MPH	Max. weight	120 MPH	Max. weight	130 MPH	Max. weight	140 MPH	Max. weight	150 MPH	Max. weight	Approximate ship weight (lbs.)
SSS	10	4C	20	500	16	400	13	325	10.5	263	8.5	213	7	175	6	150	75
SSS	12	4C	16	400	13	325	10	250	8	200	6.5	163	5	125	4	100	90
SSS	14	4C	13.5	338	10	250	7.5	188	6	150	4.5	113	3.5	88	2.5	63	100
SSS	16	4C	10.5	263	7.5	188	5.5	138	4	100	3	75	1.5	38	1	25	115
SSS	18	4C	8	200	5.5	138	4	100	2.5	63	1.5	38	0.5	13	--	--	125
SSS	18	4G	13	325	9.5	238	7	175	5	125	3.5	88	2.5	63	1.5	38	185
SSS	18	5C	13	325	9.5	238	6.5	163	4.5	113	3	75	1.5	38	.5	13	170
SSS	20	4C	6	150	4	100	2.5	63	1	25	--	--	--	--	--	--	140
SSS	20	4G	10.5	263	7.5	188	5.5	138	3.5	88	2	50	1	25	--	--	205
SSS	20	5C	10	250	7	175	4.5	113	2.5	63	1	25	--	--	--	--	185
SSS	20	5G	20	500	15	375	11.5	288	8.5	213	6	150	4.5	113	3	75	265
SSS	25	4C	2	50	0.5	13	--	--	--	--	--	--	--	--	--	--	170
SSS	25	4G	5.5	138	3	75	1.5	38	--	--	--	--	--	--	--	--	245
SSS	25	5C	4.5	113	2	50	--	--	--	--	--	--	--	--	--	--	225
SSS	25	5G	12	300	8.5	213	5.5	138	3	75	1.5	38	--	--	--	--	360
SSS	25	6G	19	475	13.5	338	9	225	5.5	138	3	75	1	25	--	--	445
SSS	30	4G	1.5	38	--	--	--	--	--	--	--	--	--	--	--	--	291
SSS	30	5C	--	--	--	--	--	--	--	--	--	--	--	--	--	--	265
SSS	30	5G	6.5	163	3.5	88	1	25	--	--	--	--	--	--	--	--	380
SSS	30	6G	11	275	6	150	2.5	63	--	--	--	--	--	--	--	--	520
SSS	35	5G	2	50	--	--	--	--	--	--	--	--	--	--	--	--	440
SSS	35	6G	4	100	--	--	--	--	--	--	--	--	--	--	--	--	540
SSS	39	6G	--	--	--	--	--	--	--	--	--	--	--	--	--	--	605

NOTE: AASHTO 2013 criteria is the most conservative existing EPA calculation. For poles not showing EPA values under AASHTO 2013, EPA values may exist under commercial criteria (see table above).

\*For 1/2 ft increments, add -6 to the pole height. Ex: 20-6 equals 20ft 6in.



## SSS Square Straight Steel Poles

### BASE DETAIL

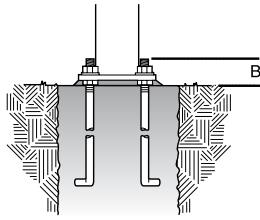
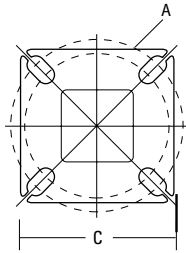
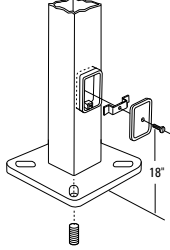

POLE DATA							
Shaft base size	Bolt circle A	Bolt projection B	Base square C	Base plate thickness	Template description	Anchor bolt description	Anchor bolt and template description
4"C	8" – 9"	3.25"– 3.75"	8"– 8.25"	0.75"	ABTEMPLATE PJ50004	AB18-0	ABS5S-4C
4"G	8" – 9"	3.38"– 3.75"	8"– 8.25"	0.875"	ABTEMPLATE PJ50004	AB30-0	ABS5S-4G
5"	10" – 12"	3.5"– 4"	11"	1"	ABTEMPLATE PJ50010	AB36-0	ABS5S-5
6"	11" – 13"	4"– 4.50"	12.5"	1"	ABTEMPLATE PJ50011	AB36-0	N/A

### HANDHOLE ORIENTATION

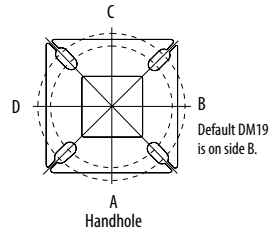

### IMPORTANT INSTALLATION NOTES:

- **Do not** erect poles without having fixtures installed.
- Factory-supplied templates must be used when setting anchor bolts. Lithonia Lighting will not accept claim for incorrect anchorage placement due to failure to use Lithonia Lighting factory templates.
- If poles are stored outside, all protective wrapping must be removed immediately upon delivery to prevent finish damage.
- Lithonia Lighting is not responsible for the foundation design.
- Bolt circles have +/- 1/2" tolerance.

**CAUTION:** These specifications are intended for general purposes only. Lithonia Lighting reserves the right to change material or design, without prior notice, in a continuing effort to upgrade its products.



## FEATURES & SPECIFICATIONS

**INTENDED USE** — Built on the compact, low-profile Z strip channel, this LED strip offers long maintenance-free life, several color temperatures, lumen outputs and lengths. Ideal for new construction and retrofit applications in T5 and T8 lengths. Ideal for uplight and downlight in commercial, retail, manufacturing, warehouse, cove and display applications. **Certain airborne contaminants can diminish the integrity of acrylic and/or polycarbonate.** [Click here for Acrylic-Polycarbonate Compatibility table for suitable uses.](#)

**CONSTRUCTION** — Compact-design channel and cover are formed from code-gauge cold-rolled steel. Easy to install row aligner included for continuous row mounting.

Finish: Paint options include high-gloss, baked white enamel (WH), galvanized (GALV), matte black (MB) and smoke gray (SKGY). After fabrication, five-stage iron phosphate pre-treatment ensures superior paint adhesion and rust resistance.

**OPTICS** — Standard diffuse snap on/snap off lens eliminates pixels, improves uniformity and minimizes glare. L/LENS option available.

**ELECTRICAL** — L70>60,000hours. Utilizes high-output LEDs integrated on a two-layer circuit board, ensuring cool-running operation. Optional internal pluggable wiring harness for reduced labor cost in row mounting applications. (See PLR\_ ordering information on page 2.) Electronic LED driver is rated for 75 input watts maximum (see Operational Data on page 4 for actual wattage consumption), **multi-volt input and 0-10V dimming standard.** This fixture is designed to withstand a maximum line surge of 2.5kV at 0.75kA combination wave for indoor locations, for applications requiring higher level of protection additional surge protection must be provided.

LEDs provide nominal 80 CRI at 3000 K, 3500 K, 4000 K, or 5000 K.

Lumen output up to 2,000 lumens per foot. In 86°F (30°C) ambient environments. Luminaire should be installed in applications where ambient temperatures do not exceed 86°F (30°C).

**INSTALLATION** — Tool-less channel cover for easy installation.

Fixture may be surface mounted (with or without ZSPRG hanger), pendant or stem mounted with appropriate mounting options. Three-point aligner locks in place for easy continuous row mounting.

**LISTINGS** — CSA certified to US and Canadian safety standards. For use in damp locations between -40°F (-40°C) and 86°F (30°C).

DesignLights Consortium® (DLC) qualified product. Not all versions of this product may be DLC qualified. Please check the DLC Qualified Products List at [www.designlights.org/QPL](http://www.designlights.org/QPL) to confirm which versions are qualified.

**BUY AMERICAN** — Product with the BAA option is assembled in the USA and meets the Buy America(n) government procurement requirements under FAR, DFARS and DOT. Please refer to [www.acuitybrands.com/buy-american](http://www.acuitybrands.com/buy-american) for additional information.

**WARRANTY** — 5-year limited warranty. This is the only warranty provided and no other statements in this specification sheet create any warranty of any kind. All other express and implied warranties are disclaimed. Complete warranty terms located at: [www.acuitybrands.com/support/warranty/terms-and-conditions](http://www.acuitybrands.com/support/warranty/terms-and-conditions)

**Note:** Actual performance may differ as a result of end-user environment and application.

All values are design or typical values, measured under laboratory conditions at 25 °C.

Specifications subject to change without notice.



LED Striplight

# ZL1N

24", 48" and 96" Lengths

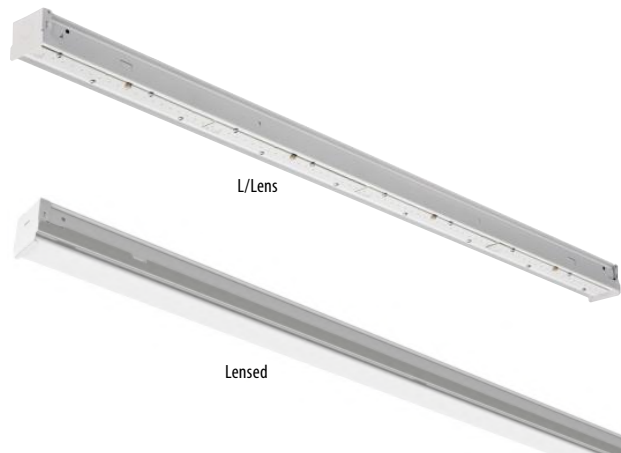

### Capable Luminaire

This item is an A+ capable luminaire, which has been designed and tested to provide consistent color appearance and out-of-the-box control compatibility with simple commissioning.

- All configurations of this luminaire meet the Acuity Brands' specification for chromatic consistency
- This luminaire is part of an A+ Certified solution for nLight® control networks marked by a [shaded background](#)\*

To learn more about A+, visit [www.acuitybrands.com/aplus](http://www.acuitybrands.com/aplus).

\*See ordering tree for details



Project 22-73934-21  
Scrubbles Car Wash ~ Blanket for 4 locations

Submitted By  
ST. LOUIS LIGHTING GROUP

Catalog Number: ZL1N L48 3000LM FST MVOLT 40K 80CRI WH

Note:

Type  
**B**

## ZL1N LED Striplight

A+ Capable options indicated by this color background.

### ORDERING INFORMATION

Lead times will vary depending on options selected. Consult with your sales representative.

**Example:** ZL1N L48 3000LM FST MVOLT 40K 80CRI WH

ZL1N	L48		3000LM	FST	MVOLT
<b>Series</b>	<b>Length</b>	<b>Reflectors†</b>	<b>Nominal lumens†</b>	<b>Diffuser</b>	<b>Voltage</b>
ZL1N LED striplight	L24 24" †	(blank) Less reflector SMR Symmetric	1500LM 1,500 lumens 2500LM 2,500 lumens 3500LM 3,500 lumens	FST Snap on frosted, diffuse L/LENS No diffuser SBL FST Straight blade louver with snap on frosted, diffuse	MVOLT 120-277V 120 120V 208 208V 240 240V 277 277V 347 347V † 480 480V †
	L46 46" L48 48"	(blank) Less reflector ASR Asymmetric (L48 only) SMR Symmetric	3000LM 3,000 lumens 5000LM 5,000 lumens 7000LM 7,000 lumens		
TZL1N LED striplight †	L92 92" L96 96"	(blank) Less reflector SMR Symmetric	6000LM 6,000 lumens 10000LM 10,000 lumens 14000LM 14,000 lumens		

40K	80CRI			WH
<b>Color temperature</b>	<b>Color rendering index</b>	<b>Options</b>	<b>Individual Controls †</b>	<b>Paint finish</b>
30K 3000 K 35K 3500 K 40K 4000 K 50K 5000 K	80CRI 80 CRI 90CRI 90 CRI	PLR___ Plug-in wiring † PLR1LVG Plug-in wiring-low voltage † E7W Power Sentry® PS750L, 7 watt emergency battery, CA Title 20 non-compliant (LINK) † 2E7W Two Power Sentry® PS750L, 7 watt emergency batteries, CA Title 20 non-compliant (LINK) † E10WLCP Power Sentry® PS1055LCP, 10 watt emergency battery, Certified in CA Title 20 MAEDBS (LINK) † 2E10WLCP Two Power Sentry® PS1055LCP, 10 watt emergency batteries, Certified in CA Title 20 MAEDBS (LINK) † E15WLCP Power Sentry® PS1555LCP, 15 watt emergency battery, Certified in CA Title 20 MAEDBS (LINK) † OUTEND Cord set to exit endplate of fixture BAA Buy America(n) Act Compliant <b>nLight® Wireless †</b> NLTAIR2 nLight® Air Generation 2 enabled, 360° low mount sensor, (7 to 15' heights) (LINK) RLSXR10 NLTAIR2 nLight® Air Generation 2 enabled, 360° low mount sensor, (7 to 15' heights), UL 924 Emergency Operation, via power interrupt detection (not available with battery pack) (LINK) † RLSXR10EM	LBOZU 360° low mount LSXR PIR sensor, (7-15' mounting heights), ON/OFF occupancy, pre-wired (LINK) † LBHOSZU 360° low mount LSXR PIR sensor, (7-15' mounting heights), high/low occupancy dimming, pre-wired (LINK) † LBPZU 360° low mount LSXR PIR sensor, (7-15' mounting heights), ON/OFF photocell, pre-wired (LINK) † LBMOSZU 360° low mount LSXR PIR sensor, (7-15' mounting heights), dimming and switching photocell, pre-wired (LINK) † <b>Cord sets: †</b> CS1W Cord with NEMA 5-15P, 120V straight blade plug, 18 gauge, 3 conductors, white, 6ft CS3W Cord with NEMA L5-15P, 120V twist lock plug, 18 gauge, 3 conductor, white, 6ft CS7W Cord with NEMA 7-15P, 277V straight blade plug, 18 gauge, 3 conductors, white, 6ft CS11W Cord with NEMA L7-15P, 277V twist lock plug, 18 gauge, 3 conductors, white, 6ft CS25W Cord with NEMA L24-20P, 347V twist lock plug, 18 gauge, 3 conductors, white, 6ft CS97W Cord with NEMA L8-20P, 480V twist lock plug, 18 gauge, 3 conductors, white, 6ft CS93W Cord only (no plug), 18 gauge, 3 conductors, white, 6ft	WH White GALV Galvanized MB Matte black SKGY Smoke gray

Accessories: Order as separate catalog number.			
HC36 M12	Hanger chain, 36" (1 pair)	ZLR L24 SYM UPL WH	24" symmetric reflector with uplight, white finish
ZACVH M100	Adjustable 10' aircraft cable with Y hanger (1 pair)	ZLR L24 SYM WH	24" symmetric reflector, white finish
ZLANGBKT	Luma-tilt™ angle bracket for shelf or ledge mounting only	ZLR L46 SYM UPL WH	46" symmetric reflector with uplight, white finish
SQ_	Swivel stem hanger (specify length in 2" increments up to 48")	ZLR L46 SYM WH	46" symmetric reflector, white finish
NPP16D	nLight® wired power/relay pack, 0-10VDC dimming output (LINK)	ZLR L48 ASY WH	48" asymmetric reflector, white finish
RPP20D	nLight® air Generation 2 enabled, power/relay pack, 0-10V dimming output (LINK)	ZLR L48 SYM UPL WH	48" symmetric reflector with uplight, white finish
LSXR	Sensor Switch® LSXR occupancy sensor (LINK)	ZLR L48 SYM WH	48" symmetric reflector, white finish
ZSPRG J2	Tong and T-grid hanger, for 15/16" T-grid (Order quantity required in multiples of 2)	ZLR L92 SYM UPL WH	92" symmetric reflector with uplight, white finish
WGZ24	24" wireguard, white †	ZLR L92 SYM WH	92" symmetric reflector, white finish
WGZ48	48" wireguard, white †	ZLR L96 SYM UPL WH	96" symmetric reflector with uplight, white finish
		ZLR L96 SYM WH	96" symmetric reflector, white finish
		UNIVERSAL REFL ALIGNER	Universal reflector aligners, quantity 1



Project 22-73934-21  
Scrubbles Car Wash ~ Blanket for 4 locations

Submitted By  
ST. LOUIS LIGHTING GROUP

Catalog Number: ZL1N L48 3000LM FST MVOLT 40K 80CRI  
WH

Note:

Type  
**B**

## ZL1N LED Striplight

### ‡ Option Value Ordering Restrictions

Option value	Restriction
2E7W	MVOLT required. Available with L92 or L96 only. Not available with L24, L46, L48, L92 6000LM, L96 6000LM or any cordset that includes a plug.
2E10WLCP	MVOLT required. Available with L92 or L96 with 10,000LM or 14000LM only. Not available with L24, L46, L48, L92 6000LM, L96 6000LM or any cordset that includes a plug.
347, 480	Utilizes step down transformer.
Cord Sets	Must specify voltage when plug is included. Cordsets exit back of fixture unless OUTEND option is specified.
E7W	MVOLT required. Available with L46, L48, L92 or L96 with 10000LM or 14000LM only. Not available with L24 or any cordset that includes a plug.
E10WLCP	MVOLT required. Available with L46, L48, L92 or L96 only. Not available with L24 or any cordset that includes a plug.
E15WLCP	MVOLT required. Available with L92 or L96 only. Not available with L24, L46, L48 or any cordset that includes a plug.
HTZL1N	Tandem fixture ships as two L46 or L48 fixtures.
Individual Controls	Available with MVOLT, 347 or 480 only. See ordering information on page 6 for more configurations. This sensor configuration is suitable for minimum ambient temperature of 14°F (-10°C). See page 5 for low temperature option providing -4°F (-20°C) minimum ambient. When choosing Sensor and PLR for same fixture, consult the factory. Sensors come prewired, they must be snapped into place at time of installation.
L24	Not available with 347V, 480V or emergency batteries.
nLight® Wireless	See LINK in sensor description to RLSXR specification sheet for more configurations. When choosing a sensor and PLR for same fixture, consult the factory. Sensors come prewired, they must be snapped into place at time of installation.
NLTAIR2 RLSXR10EM	Not available with 347 or 480. MVOLT required.
Nominal Lumens	See Operational Data on page 2 for actual lumens.
PLR ___	Not available with cordset options. Not available with sensor options. See ordering information on page 5.
PLR1LVG	Not available with cordset options. Not available with sensor options.
Reflectors	Optional. Reflectors ship separately.
WGZ24	Not available with ASR or SMR reflector options.
WGZ48	Not available with ASR or SMR reflector options. Order a Qty of 2 for L92 or L96 tandem fixtures.

## ZL1N LED Striplight

OPERATIONAL DATA												
	Nominal lumen package	Length (inches)	Delivered Lumens 3000 K CCT @ 77°F (25°C) ambient temperature		Delivered Lumens 3500 K CCT @ 77°F (25°C) ambient temperature		Delivered Lumens 4000 K CCT @ 77°F (25°C) ambient temperature		Delivered Lumens 5000 K CCT @ 77°F (25°C) ambient temperature		Wattage @ 120V/277V	Comparable Light Source
			80 CRI	90 CRI	80 CRI	90 CRI	80 CRI	90 CRI	80 CRI	90 CRI		
Lensed	1500LM	24	1738	1409	1777	1467	1804	1494	1871	1528	15	1-lamp 17W T8
	2500LM	24	2265	1846	2315	1900	2351	1947	2438	1991	19	1-lamp 17W T8
	3500LM	24	3586	2924	3666	3026	3723	3084	3860	3152	31	1-lamp 32W T8, 1-lamp 54W T5HO, 50W HID
	3000LM	46 or 48	3172	2586	3243	2677	3293	2728	3415	2788	25	1-lamp 32W T8, 1-lamp 54W T5HO, 50W HID
	5000LM	46 or 48	4417	3601	4515	3727	4585	3798	4754	3882	34	2-lamp 32W T8, 1-lamp 54W T5HO, 70W HID
	7000LM	46 or 48	6535	5328	6681	5515	6785	5619	7035	5744	52	3-lamp 32W T8, 2-lamp 54W T5HO, 100W HID
	6000LM	92 or 96	6561	5349	6708	5537	6812	5642	7063	5767	48	3-lamp 32W T8, 2-lamp 54W T5HO, 100W HID
	10000LM	92 or 96	8687	7082	8881	7331	9019	7470	9351	7636	68	4-lamp 32W T8, 2-lamp 54W T5HO, 100W HID
14000LM	92 or 96	12457	10513	12735	10665	12933	10711	13409	10949	104	4-lamp 32W T8, 3-lamp 54W T5HO, 150W HID	
Unlensed	1500LM	24	1881	1534	1923	1588	1953	1618	2025	1654	15	1-lamp 17W T8
	2500LM	24	2452	1999	2506	2069	2545	2108	2639	2155	19	1-lamp 17W T8
	3500LM	24	3882	3165	3969	3276	4031	3338	4179	3412	31	1-lamp 32W T8, 1-lamp 54W T5HO, 50W HID
	3000LM	46 or 48	3434	2800	3511	2898	3565	2953	3697	3019	25	1-lamp 32W T8, 1-lamp 54W T5HO, 50W HID
	5000LM	46 or 48	4781	3898	4888	4035	4964	4111	5147	4203	34	2-lamp 32W T8, 1-lamp 54W T5HO, 70W HID
	7000LM	46 or 48	7075	5768	7233	5971	7345	6083	7616	6219	52	3-lamp 32W T8, 2-lamp 54W T5HO, 100W HID
	6000LM	92 or 96	7103	5791	7261	5995	7374	6108	7646	6243	48	3-lamp 32W T8, 2-lamp 54W T5HO, 100W HID
	10000LM	92 or 96	9404	7667	9614	7937	9764	8087	10123	8266	68	4-lamp 32W T8, 2-lamp 54W T5HO, 100W HID
14000LM	92 or 96	13485	10994	13786	11381	14001	11596	14516	11853	104	4-lamp 32W T8, 3-lamp 54W T5HO, 150W HID	

## PROJECTED LUMEN MAINTENANCE

Operating Hours	0	15,000	30,000	45,000	60,000	100,000
Lumen Maintenance Factor	1	0.94	0.89	0.83	0.79	0.67

## DIMENSIONS

All dimensions are shown in inches (centimeters) unless otherwise noted.  
Specifications subject to change without notice.

PALLET DIMENSIONS			
Length	Approximate weight	Fixtures per pallet	Approximate pallet dimensions (L x W x H)
L24	7 lbs.	408	46" X 51" X 32 11/16"
L46	11 lbs.	176	46" X 51" X 32 1/16"
L48	12 lbs.	176	46" X 51" X 31 3/8"
L92	22 lbs.	176	46" X 98 1/2" X 31 1/16"
L96	24 lbs.	176	46" X 98 1/2" X 31 1/16"

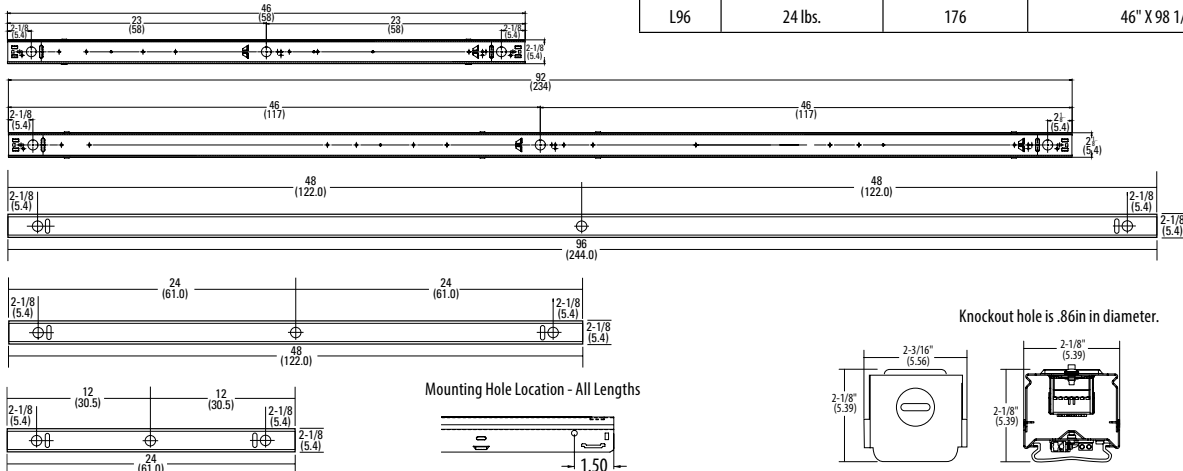

## PHOTOMETRICS

Please see [www.lithonia.com](http://www.lithonia.com)

## ZL1N LED Striplight

### REFLECTORS (Optional)

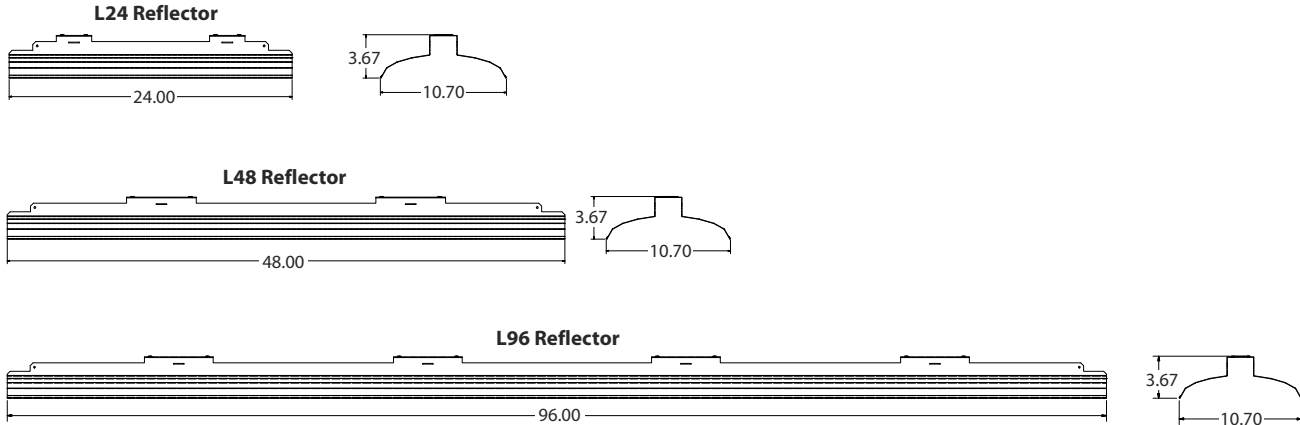

### PHOTOMETRICS

Please see [www.lithonia.com](http://www.lithonia.com)

### PLUG-IN WIRING INFORMATION

Advanced plug-in system with two-circuit capability. Available on industrial and strip products and a variety of architectural products mounted in continuous. PLR22 (2-circuit) and crossover harness switches hot circuit serving next fixture in row. Reduces fixture types on job for alternating circuit applications (see example below.)

Easy one-step installation, saves up to 35% on labor costs. Expanded switching flexibility helps save energy.

Rows can be 50% longer with two-circuit systems. Polarized, lock-together nylon connectors prevent miswiring in the field. #12 THHN conductor, rated 600V, 90°C. White neutral wire included. Grounding accomplished by fixture in-row connectors.

CSA certified systems available with up to 2 circuits. G ground required.

Not for use with dedicated emergency circuits.

Note: Specifications subject to change without notice.



Wiring

# PLR

Advanced 1 or 2-Circuit Plug-In

#### ORDERING INFORMATION

Lead times will vary depending on options selected. Consult with your sales representative.

Series	Number of hot wires	Branch circuits	Dimming	Ground
PLR	(blank) Not required for PLR22	<u>Circuits to which driver is connected</u>		
PLR22	1 Black	(blank) Not required for PLR22 or PLR1	LV Low-voltage dimming	G Ground (required)
	2 Black and red	A Black wire		
		B Red wire		
		Battery charging circuit (must be unswitched)		
		(blank) No battery charging circuit		
		ELA Battery pack wired to black wire		
		ELB Battery pack wired to red wire		

#### Typical Applications

- Multiple-circuit and single-circuit for longer continuous rows
- Multiple-circuit with alternating fixtures on separate circuits, 2-circuit (PLR22)
- Multiple circuit with night-lights located along row as desired



Project 22-73934-21  
Scrubbles Car Wash ~ Blanket for 4 locations

Submitted By  
ST. LOUIS LIGHTING GROUP

Catalog Number: ZL1N L48 3000LM FST MVOLT 40K 80CRI  
WH

Note:

Type  
**B**

## ZL1N LED Striplight

### LSXR — Fixture Mount Occupancy Sensor (see [www.AcuityControls.com](http://www.AcuityControls.com) for additional information)

- Three interchangeable lens options to satisfy multiple mounting heights and coverage pattern requirements.
- Integrated mounting bracket drops lens down 3" from chase nipple.
- Single or dual relay versions — designed with robust protection from the harsh switching requirements of TS and LED loads.
- Photocell and 0-10VDC dimming options.
- No PIR field calibration or sensitivity adjustments required.
- Sensor ambient temperature rating of 14°F (-10°C) to 131°F (55°C).

LSXR configuration	Comparable CMRB sensor	Old style sensor nomenclature
<b>For shortest lead times use one of the following LSXR configurations</b>		
LCOZU	CMRB 50	MSI
LCHOSZU	CMRB 50 D	MSID
LCPZU	CMRB 50 P	MSIPED
LAOZU	CMRB 6	MSI360
LAHOSZU	CMRB 6 D	MSI360D
LAPZU	CMRB 6 P	MSI360PED

**SELECTIONS BELOW WILL EXTEND ORDER LEAD TIME. CONSULT YOUR SALES REPRESENTATIVE FOR DETAILS.**

### SINGLE RELAY

#### ORDERING INFORMATION

**Example:** LAHOSZU

Series	Lens option	Dimming/Photocell	Max. dim level	Min. dim level	Temp/Humidity	Default occupancy time delay
L LSXR passive infrared indoor occupancy sensor	A High mount, 360°	O None <sup>1</sup>	0 10VDC	5 Minimum dim level of ballast	Z None	I 30 sec
		H High/low occupancy operation	9 9VDC	1 1VDC	T Low temperature <sup>2</sup>	D 2.5 min
	B Low mount, 360°	P Switching photocell (on/off) <sup>1</sup>	8 8VDC	2 2VDC		X 5.0 min
		M Dimming and switching photocell	7 7VDC	3 3VDC		R 7.5 min
	C High mount aisleway	G Dimming and switching photocell with high/low occupancy operation		4 4VDC		U 10.0 min (with minimum 15 minute on time)
				5 5VDC		V 15.0 min
				6 6VDC		W 20.0 min
					Y 30.0 min	

#### Notes

- 1 Max and min dim levels not applicable with this option.
- 2 Ambient temperature rating of -4°F (-20°C) to 131°F (55°C).

### DUAL RELAY (Available with 120, 277, and 347V only)

#### ORDERING INFORMATION

**Example:** LA2KZU

Series	Lens option	Poles	Operating mode	Temp/Humidity	Default occupancy time delay
L LSXR passive infrared indoor occupancy sensor	A High mount, 360°	2 Dual relay	J None	Z None	I 30 sec
			K Alternating off relays (promotes even lamp wear)	T Low temperature <sup>1</sup>	D 2.5 min
	O Alternating off relays w/photocell			X 5.0 min	
	P Switching photocell (on/off)			R 7.5 min	
	E Photocell on/off (pole 1 only)			U 10.0 min (with minimum 15 minute on time)	
	F Photocell on/off - both poles (dual set-point)			V 15.0 min	
				W 20.0 min	
				Y 30.0 min	

#### Notes

- 1 Ambient temperature rating of -4°F (-20°C) to 131°F (55°C).

**Example:** LENS 50 J100

Replacement lenses: Order as separate catalog number.		
Series	Lens type	Package quantity
LENS	6 High mount 360°	[blank] Single Lens
	10 Low mount 360°	J10 10-pack
	50 High mount aisleway	J100 100-pack



## ZL1N LED Striplight

### OPTIONS AND ACCESSORIES

The Z Series fixture offers numerous options for almost every electrical and optical component, including a long list of field-installable accessories.



#### HANGER CHAIN

36" chain with Y hanger.

Order as:  
HC36

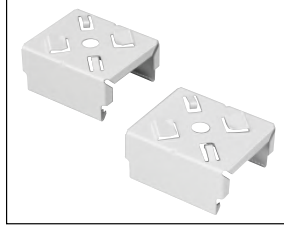

#### Z SPRING HANGER

Snap 'n' lock design requires no fasteners and can be used on T-grid ceiling or universal mounting systems.

Order as:  
ZSPRG J2



#### ZACVH HANGER

10' Aircraft cable with Y hanger.

Order as:  
ZACVH



#### ANGLE MOUNTING BRACKET

Luma-tilt™ angle bracket ships as a pair

Order as:  
ZLANGBKT

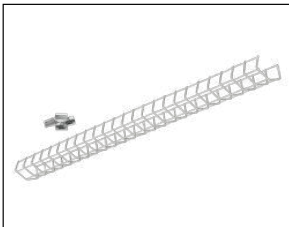

#### WIRE GUARD

Order as:  
WGZ24  
WGZ48

## ZL1N LED Striplight

### OPTIONS AND ACCESSORIES

The Z Series fixture offers numerous options for almost every electrical and optical component, including a long list of field-installable accessories.



#### HANGER CHAIN

36" chain with Y hanger.

Order as:  
HC36

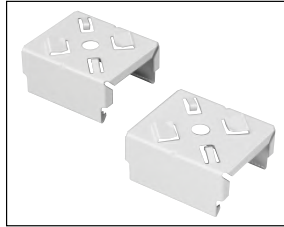

#### Z SPRING HANGER

Snap 'n' lock design requires no fasteners and can be used on T-grid ceiling or universal mounting systems.

Order as:  
ZSPRG J2



#### ZACVH HANGER

10' Aircraft cable with Y hanger.

Order as:  
ZACVH

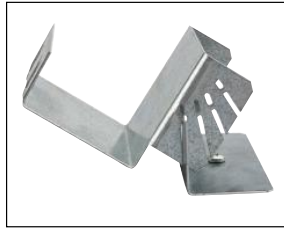

#### ANGLE MOUNTING BRACKET

Luma-tilt™ angle bracket ships as a pair

Order as:  
ZLANGBKT

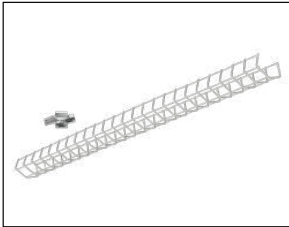

#### WIRE GUARD

Order as:  
WGZ24  
WGZ48



## WDGE1 LED

### Architectural Wall Sconce



#### Specifications

<b>Depth (D1):</b>	5.5"
<b>Depth (D2):</b>	1.5"
<b>Height:</b>	8"
<b>Width:</b>	9"
<b>Weight:</b> (without options)	9 lbs

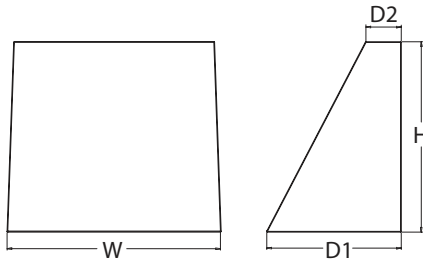

#### Introduction

The WDGE LED family is designed to meet specifier's every wall-mounted lighting need in a widely accepted shape that blends with any architecture. The clean rectilinear design comes in four sizes with lumen packages ranging from 1,200 to 25,000 lumens, providing true site-wide solution.

WDGE1 delivers up to 2,000 lumens with a soft, non-pixelated light source, creating a visually comfortable environment. The compact size of WDGE1, with its integrated emergency battery backup option, makes it an ideal over-the-door wall-mounted lighting solution.

#### WDGE LED Family Overview

Luminaire	Standard EM, 0°C	Cold EM, -20°C	Sensor	Lumens (4000K)					
				P1	P2	P3	P4	P5	P6
WDGE1 LED	4W	--	--	1,200	2,000	--	--	--	--
WDGE2 LED	10W	18W	Standalone / nLight	1,200	2,000	3,000	4,500	6,000	--
WDGE3 LED	15W	18W	Standalone / nLight	7,500	8,500	10,000	12,000	--	--
WDGE4 LED	--	--	Standalone / nLight	12,000	16,000	18,000	20,000	22,000	25,000

#### Ordering Information

**EXAMPLE: WDGE1 LED P2 40K 80CRI VF MVOLT SRM PE DDBXD**

WDGE1	P2	40K	80CRI	VF	MVOLT	SRM
Series	Package	Color Temperature	CRI	Distribution	Voltage	Mounting
WDGE1 LED	P1 P2	27K 2700K 30K 3000K 35K 3500K 40K 4000K 50K <sup>1</sup> 5000K	80CRI 90CRI	VF Visual comfort forward throw VW Visual comfort wide	MVOLT 347 <sup>2</sup>	<b>Shipped included</b> SRM Surface mounting bracket ICW Indirect Canopy/Ceiling Washer bracket (dry/damp locations only) <sup>5</sup> <b>Shipped separately</b> AWS 3/8inch Architectural wall spacer PBBW Surface-mounted back box (top, left, right conduit entry) Use when there is no junction box available.

Options		DDBXD	
		Finish	
E4WH <sup>3</sup>	Emergency battery backup, Certified in CA Title 20 MAEDBS (4W, 0°C min)	DDBXD	Dark bronze
PE <sup>4</sup>	Photocell, Button Type	DBLXD	Black
DS	Dual switching (comes with 2 drivers and 2 light engines; see page 3 for details)	DNAXD	Natural aluminum
DMG	0-10V dimming wires pulled outside fixture (for use with an external control, ordered separately)	DWHXD	White
BCE	Bottom conduit entry for back box (PBBW). Total of 4 entry points.	DSSXD	Sandstone
BAA	Buy America(n) Act Compliant	DDBTXD	Textured dark bronze
		DBLTXD	Textured black
		DNATXD	Textured natural aluminum
		DWHGXD	Textured white
		DSSTXD	Textured sandstone

#### Accessories

Ordered and shipped separately.

WDGEAWS DDBXD	WDGE 3/8inch Architectural Wall Spacer (specify finish)
WDGE1PBBW DDBXD U	WDGE1 surface-mounted back box (specify finish)

#### NOTES

- 50K not available in 90CRI.
- 347V not available with E4WH, DS or PE.
- E4WH not available with PE or DS.
- PE not available with DS.
- Not qualified for DLC. Not available with E4WH.



Project 22-73934-21  
Scrubbles Car Wash ~ Blanket for 4 locations

Submitted By  
ST. LOUIS LIGHTING GROUP

Catalog Number: WDGE1 LED P2 40K 80CRI VF MVOLT  
SRM DDBXD

Note:

Type  
**WP**

## Performance Data

### Lumen Output

Lumen values are from photometric tests performed in accordance with IESNA LM-79-08. Data is considered to be representative of the configurations shown, within the tolerances allowed by Lighting Facts. Contact factory for performance data on any configurations not shown here.

Performance Package	System Watts	Dist. Type	27K (2700K, 80 CRI)					30K (3000K, 80 CRI)					35K (3500K, 80 CRI)					40K (4000K, 80 CRI)					50K (5000K, 80 CRI)				
			Lumens	LPW	B	U	G	Lumens	LPW	B	U	G	Lumens	LPW	B	U	G	Lumens	LPW	B	U	G	Lumens	LPW	B	U	G
P1	10W	VF	1,120	112	0	0	0	1,161	116	0	0	0	1,194	119	0	0	0	1,227	123	0	0	0	1,235	123	0	0	0
		VW	1,122	112	0	0	0	1,163	116	0	0	0	1,196	120	0	0	0	1,229	123	0	0	0	1,237	124	0	0	0
P2	15W	VF	1,806	120	1	0	0	1,872	125	1	0	0	1,925	128	1	0	0	1,978	132	1	0	0	1,992	133	1	0	0
		VW	1,809	120	1	0	0	1,876	125	1	0	0	1,929	128	1	0	0	1,982	132	1	0	0	1,996	133	1	0	0

### Electrical Load

Performance Package	System Watts	Current (A)				
		120V	208V	240V	277V	347V
P1	10W	0.082	0.049	0.043	0.038	--
	13W	--	--	--	--	0.046
P2	15W	0.132	0.081	0.072	0.064	--
	18W	--	--	--	--	0.056

### Lumen Multiplier for 90CRI

CCT	Multiplier
27K	0.845
30K	0.867
35K	0.845
40K	0.885
50K	0.898

### Lumen Output in Emergency Mode (4000K, 80 CRI)

Option	Dist. Type	Lumens
E4WH	VF	646
	VW	647

### Lumen Ambient Temperature (LAT) Multipliers

Use these factors to determine relative lumen output for average ambient temperatures from 0-40°C (32-104°F).

Ambient	Lumen Multiplier
0°C / 32°F	1.03
10°C / 50°F	1.02
20°C / 68°F	1.01
25°C / 77°F	1.00
30°C / 86°F	0.99
40°C / 104°F	0.98

### Projected LED Lumen Maintenance

Data references the extrapolated performance projections for the platforms noted in a 25°C ambient, based on 10,000 hours of LED testing (tested per IESNA LM-80-08 and projected per IESNA TM-21-11).

To calculate LLF, use the lumen maintenance factor that corresponds to the desired number of operating hours below. For other lumen maintenance values, contact factory.

Operating Hours	0	25,000	50,000	100,000
Lumen Maintenance Factor	1.0	>0.96	>0.95	>0.91

## Photometric Diagrams

To see complete photometric reports or download .ies files for this product, visit the Lithonia Lighting WDGE LED homepage. Tested in accordance with IESNA LM-79 and LM-80 standards.

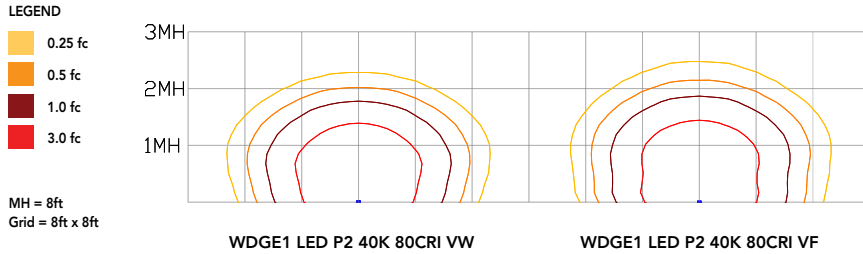

## Emergency Egress Options

### Emergency Battery Backup

The emergency battery backup is integral to the luminaire — no external housing required! This design provides reliable emergency operation while maintaining the aesthetics of the product. All emergency battery backup configurations include an independent secondary driver with an integral relay to immediately detect loss of normal power and automatically energize the luminaire. The emergency battery will power the luminaire for a minimum duration of 90 minutes (maximum duration of three hours) from the time normal power is lost and maintain a minimum of 60% of the light output at the end of 90minutes.

Applicable codes: NFPA 70/NEC – section 700.16, NFPA 101 Life Safety Code Section 7.9

The example below shows illuminance of 1 fc average and 0.1 fc minimum in emergency mode with E4WH and VF distribution.

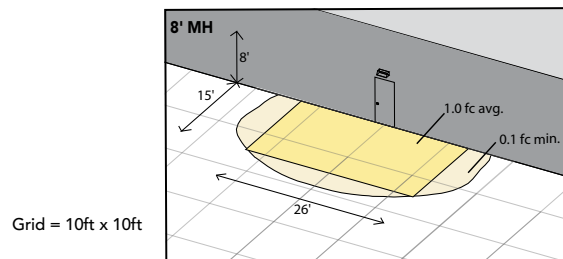

WDGE1 LED xx 40K 80CRI VF MVOLT E4WH

### Dual Switching (DS) Option

The dual switching option offers operational redundancy that certain codes require. With this option the luminaire comes integrated with two drivers and two light engines. These work completely independent to each other so that a failure of any individual component does not cause the whole luminaire to go dark. This option is typically used with a back generator or inverter providing emergency power.

Applicable codes: NFPA 70/NEC – section 700.16, NFPA 101 Life Safety Code Section 7.9

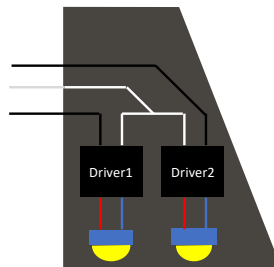

## Mounting, Options & Accessories



### E4WH – 4W Emergency Battery Backup

D = 5.5"  
H = 8"  
W = 9"



### PBBW – Surface-Mounted Back Box

**Use when there is no junction box available.**

D = 1.75"  
H = 8"  
W = 9"



### AWS – 3/8inch Architectural Wall Spacer

D = 0.38"  
H = 4.4"  
W = 7.5"

## FEATURES & SPECIFICATIONS

### INTENDED USE

Common architectural look, with clean rectilinear shape, of the WDGE LED was designed to blend with any type of construction, whether it be tilt-up, frame or brick. Applications include commercial offices, warehouses, hospitals, schools, malls, restaurants, and other commercial buildings.

### CONSTRUCTION

The single-piece die-cast aluminum housing integrates secondary heat sinks to optimize thermal transfer from the internal light engine heat sinks and promote long life. The driver is mounted in direct contact with the casting for a low operating temperature and long life. The die-cast door frame is fully gasketed with a one-piece solid silicone gasket to keep out moisture and dust, providing an IP66 rating for the luminaire.

### FINISH

Exterior painted parts are protected by a zinc-infused Super Durable TGIC thermoset powder coat finish that provides superior resistance to corrosion and weathering. A tightly controlled multi-stage process ensures a 3 mils thickness for a finish that can withstand extreme climate changes without cracking or peeling. Standard Super Durable colors include dark bronze, black, natural aluminum, sandstone and white. Available in textured and non-textured finishes.

### OPTICS

Well crafted reflector optics allow the light engine to be recessed within the luminaire, providing visual comfort, superior distribution, uniformity, and spacing in wall-mount applications. The WDGE LED has zero uplight and qualifies as a Nighttime Friendly™ product, meaning it is consistent with the LEED® and Green Globes™ criteria for eliminating wasteful uplight.

### ELECTRICAL

Light engine consists of high-efficacy LEDs mounted to metal-core circuit boards to maximize heat dissipation and promote long life (up to L91/100,000 hours at 25°C). The electronic driver has a power factor of >90%, THD <20%. Luminaire comes with built in 6kV surge protection, which meets a minimum Category C low exposure (per ANSI/IEEE C62.41.2). Fixture ships standard with 0-10v dimmable driver.

### INSTALLATION

A universal mounting plate with integral mounting support arms allows the fixture to hinge down for easy access while making wiring connections. The 3/8" Architectural Wall Spacer (AWS) can be used to create a floating appearance or to accommodate small imperfections in the wall surface. The ICW option can be used to mount the luminaire inverted for indirect lighting in dry and damp locations. Design can withstand up to a 1.5 G vibration load rating per ANSI C136.31.

### LISTINGS

CSA certified to U.S. and Canadian standards. Luminaire is IP66 rated. PIR options are rated for wet location. Rated for -40°C minimum ambient. DesignLights Consortium® (DLC) Premium qualified product and DLC qualified product. Not all versions of this product may be DLC Premium qualified or DLC qualified. Please check the DLC Qualified Products List at [www.designlights.org/QPL](http://www.designlights.org/QPL) to confirm which versions are qualified. International Dark-Sky Association (IDA) Fixture Seal of Approval (FSA) is available for all products on this page utilizing 2700K and 3000K color temperature only and SRM mounting only.

### BUY AMERICAN ACT

Product with the BAA option is assembled in the USA and meets the Buy America(n) government procurement requirements under FAR, DFARS and DOT regulations. Please refer to [www.acuitybrands.com/buy-american](http://www.acuitybrands.com/buy-american) for additional information.

### WARRANTY

5-year limited warranty. This is the only warranty provided and no other statements in this specification sheet create any warranty of any kind. All other express and implied warranties are disclaimed. Complete warranty terms located at: [www.acuitybrands.com/support/warranty/terms-and-conditions](http://www.acuitybrands.com/support/warranty/terms-and-conditions)

**Note:** Actual performance may differ as a result of end-user environment and application. All values are design or typical values, measured under laboratory conditions at 25 °C. Specifications subject to change without notice.



# AMENDED SITE DEVELOPMENT SECTION PLAN

A TRACT OF LAND BEING LOT D OF TSG CHESTERFIELD AIRPORT ROAD, A SUBDIVISION ACCORDING TO THE PLAT THERE OF AS RECORDED IN PLAT BOOK 368, PAGE 313, BEING PART OF U.S. SURVEYS 125 AND 126 IN, TOWNSHIP 45 NORTH, RANGE 4 EAST OF THE 5TH PRINCIPAL MERIDIAN, CITY OF CHESTERFIELD, ST. LOUIS COUNTY, MISSOURI

## ABBREVIATIONS

ATG	ADJUST TO GRADE
B.C.	BACK OF CURB
C.O.	CLEANOUT
D.B.	DEED BOOK
E	ELECTRIC
ELEV.	ELEVATION
EX.	EXISTING
F.C.	FACE OF CURB
FL	FLOWLINE
FT.	FEET
FND.	FOUND
G	GAS
H.W.	HIGH WATER
LFB	LOW FLOW BLOCKED
M.H.	MANHOLE
N/F	NOW OR FORMERLY
N/F	NOW OR FORMERLY
PG.	PAGE
PR.	PROPOSED
P.V.C.	POLYVINYL CHLORIDE PIPE
R.C.P.	REINFORCED CONCRETE PIPE
R/W	RIGHT-OF-WAY
SQ.	SQUARE
T.B.A.	TELEPHONE CABLE TO BE ABANDONED
T.B.R.	TO BE REMOVED
T.B.R.R.	TO BE REMOVED AND REPLACED
TYP.	TYPICALLY
U.P.	USE IN PLACE
U.O.N.	UNLESS OTHERWISE NOTED
V.C.P.	VITRIFIED CLAY PIPE
W	WATER
(B+W)	RIGHT-OF-WAY WIDTH

## LEGEND

EXISTING SANITARY SEWER	
EXISTING STORM SEWER	
EXISTING TREE	
EXISTING BUILDING	
EXISTING CONTOUR	
SPOT ELEVATION	
EXISTING UTILITIES	
FOUND 1/2" IRON PIPE	
SET IRON PIPE	
FOUND CROSS	
FOUND STONE	
FIRE HYDRANT	
LIGHT STANDARD	
BUSH	
SIGN	
NOTES PARKING SPACES	
GUY WIRE	
POWER POLE	
WATER VALVE	
DENOTES RECORD INFORMATION	
ACCESSIBLE PARKING	
PROPOSED CONTOUR	
PROPOSED SPOT	
PROPOSED STORM	
PROPOSED SANITARY	

## LOCATION MAP

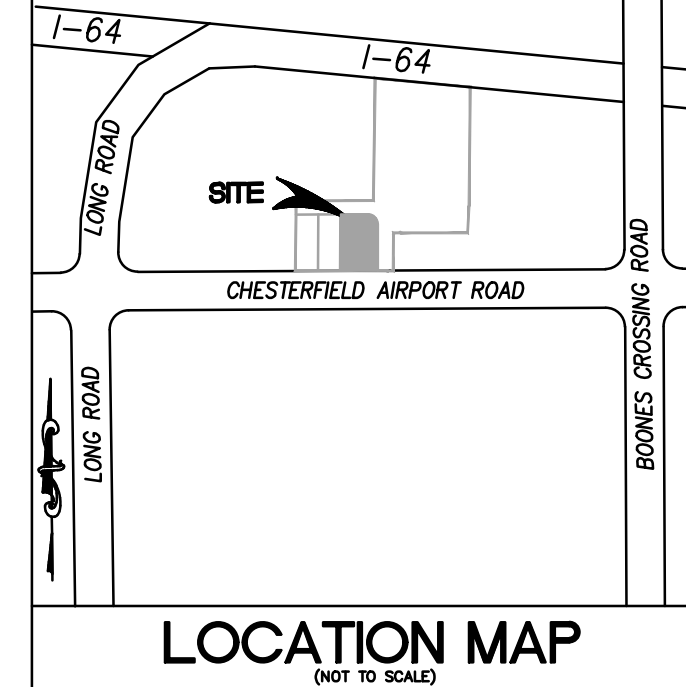

## PERTINENT DATA

OWNER: SCRUBBLES EXPRESS WASH CHESTERFIELD AIRPORT ROAD, LLC  
 ADDRESS: 34 ARNAGE ROAD, CHESTERFIELD, MO 63005  
 EXISTING ZONING: "PC" PLANNED COMMERCIAL (ORD. 3206)  
 LOCATOR NO: 17U230403  
 FIRE DISTRICT: MONARCH FIRE PROTECTION DISTRICT  
 SCHOOL DISTRICT: ROCKWOOD  
 SEWER DISTRICT: METROPOLITAN ST. LOUIS SEWER DIST.  
 WATER SHED: MISSOURI RIVER  
 FEMA MAP: 29189C0165K  
 AMEREN UE: AMEREN UE  
 SPIRE INC.: SPIRE INC.  
 AT&T: AT&T  
 MISSOURI AMERICAN WATER COMPANY: MISSOURI AMERICAN WATER COMPANY



## GENERAL NOTES

- BOUNDARY AND TOPOGRAPHY SURVEY BY STOCK & ASSOCIATES CONSULTING ENGINEERS, INC.
- ALL UTILITIES SHOWN HAVE BEEN LOCATED BY THE ENGINEER FROM AVAILABLE RECORDS. THEIR LOCATION SHOULD BE CONSIDERED APPROXIMATE. THE CONTRACTOR HAS THE RESPONSIBILITY TO NOTIFY ALL UTILITY COMPANIES, PRIOR TO CONSTRUCTION, TO HAVE EXISTING UTILITIES FIELD LOCATED.
- NO GRADE SHALL EXCEED 3:1 SLOPE.
- GRADING AND STORM WATER PER M.S.D., MODOOT, ST. LOUIS COUNTY, THE CITY OF CHESTERFIELD AND THE MONARCH CHESTERFIELD LEVEE DISTRICT.
- STORMWATER SHALL BE DISCHARGED AT ADEQUATE NATURAL DISCHARGE POINT. SINKHOLES ARE NOT ADEQUATE DISCHARGE POINTS.
- ALL UTILITIES WILL BE INSTALLED UNDERGROUND.
- SITE DEVELOPMENT SHALL BE IN ACCORDANCE WITH RECOMMENDATIONS AS OUTLINED IN THE GEOTECHNICAL REPORT AND ALL ITS SUPPLEMENTAL PROVISIONS AND ADDENDUMS.
- SIGNAGE APPROVAL IS A SEPARATE PROCESS.
- THE CONTROLLING REGULATORY FLOODPLAIN ELEVATION FOR THIS SITE IS THE 100-YEAR HIGH WATER ELEVATION OF 458.00 IN ACCORDANCE WITH THE CHESTERFIELD VALLEY STORMWATER MASTER PLAN.
- ALL ABOVE GROUND UTILITY FACILITIES TALLER THAN TWO (2) FEET IN HEIGHT OR COVERING IN EXCESS OF FOUR (4) SQUARE FEET IN SIZE SHALL BE SCREENED FROM PUBLIC VIEW IF SCREENING IS COMPLETED BY LANDSCAPE MATERIAL. A LANDSCAPE PLAN IDENTIFYING THE SIZE, LOCATION, AND SPECIES SHALL BE SUBMITTED AND APPROVED BY THE CITY PRIOR TO INSTALLATION OF ANY FACILITY.

## LEGAL DESCRIPTION

A TRACT OF LAND BEING ALL OF PART OF LOT D OF TSG CHESTERFIELD AIRPORT ROAD A SUBDIVISION THEREOF AS RECORDED IN PLAT BOOK 368, PAGE 313, LOCATED IN TOWNSHIP 45 NORTH, RANGE 4 EAST OF THE FIFTH PRINCIPAL MERIDIAN, CITY OF CHESTERFIELD, ST. LOUIS COUNTY, MISSOURI, BEING MORE PARTICULARLY DESCRIBED AS FOLLOWS:

BEGINNING AT THE SOUTHEAST CORNER OF ABOVE SAID LOT D, SAID POINT ALSO BEING LOCATED ON THE NORTH RIGHT-OF-WAY LINE OF CHESTERFIELD AIRPORT ROAD, VARIABLE WIDTH THENCE ALONG SAID RIGHT-OF-WAY LINE, SOUTH 89 DEGREES 35 MINUTES 35 SECONDS WEST, 194.56 FEET; THENCE DEPARTING SAID RIGHT-OF-WAY LINE, NORTH 00 DEGREES 24 MINUTES 25 SECONDS WEST, 311.29 FEET TO THE SOUTH LINE OF ARNAGE ROAD, 56 FEET WIDE; THENCE ALONG SAID SOUTH LINE, NORTH 89 DEGREES 35 MINUTES 32 SECONDS EAST, 152.34 FEET TO A POINT OF CURVATURE TO THE RIGHT, HAVING A RADIUS OF 45.00 FEET, AN ARC LENGTH OF 71.16 FEET TO A POINT OF TANGENCY, SAID POINT BEING LOCATED ON THE WEST LINE OF A PRIVATE ROAD (A.K.A JAGUAR LAND ROVER WAY), SAID POINT ALSO BEING LOCATED ON THE EAST LINE OF ABOVE SAID LOT D; THENCE ALONG THE COMMON LINE BETWEEN LOT D AND SAID PRIVATE ROAD, SOUTH 00 DEGREES 11 MINUTES 27 SECONDS WEST, 265.84 FEET TO THE POINT OF BEGINNING, CONTAINING 60,627 SQUARE FEET OR 1.392 ACRES, MORE OR LESS.

## CONTRACTOR'S INSURANCE REQUIREMENTS

PRIOR TO OBTAINING A CONSTRUCTION PERMIT FROM THE METROPOLITAN ST. LOUIS SEWER DISTRICT, THE CONTRACTOR SHALL BE REQUIRED TO PROVIDE THE DISTRICT WITH A COPY OF AN EXECUTED CERTIFICATE OF INSURANCE INDICATING THAT THE PERMITTEE HAS OBTAINED AND WILL CONTINUE TO CARRY COMMERCIAL GENERAL LIABILITY AND COMPREHENSIVE AUTO LIABILITY INSURANCE. THE REQUIREMENTS AND LIMITS SHALL BE AS STATED IN THE RULES AND REGULATIONS AND ENGINEERING DESIGN REQUIREMENTS FOR SANITARY AND STORMWATER DRAINAGE FACILITY, SECTION 10.090 (ADDENDUM).

## UTILITY NOTE

UNDERGROUND FACILITIES, STRUCTURES AND UTILITIES HAVE BEEN PLOTTED FROM AVAILABLE SURVEYS, RECORDS AND INFORMATION, AND THEREFORE DO NOT NECESSARILY REFLECT THE ACTUAL EXISTENCE, NON-EXISTENCE, SIZE, NUMBER, OR LOCATION OF THESE FACILITIES, STRUCTURES AND UTILITIES. THE CONTRACTOR SHALL BE RESPONSIBLE FOR VERIFYING THE ACTUAL LOCATION OF ALL UNDERGROUND FACILITIES, STRUCTURES, AND UTILITIES, EITHER SHOWN OR NOT SHOWN APPROXIMATELY 0.1 mile east of Long Road, roughly 58 feet west of the centerline of Caprice Drive, 43 feet south of the centerline of Chesterfield Airport Road, and 69 feet east of a fire hydrant.

## SITE BENCHMARK

BENCHMARK "SQ" ON LIGHT POLE at the Southwest corner of 17505 Chesterfield Airport Road  
 ELEV: 464.89

## PREPARED FOR

TSG CHESTERFIELD AIRPORT ROAD, LLC & TIFTON CAR WASH, LLC  
 2127 INNERBELT BUSINESS CENTER DR., P.O. BOX 7726  
 SUITE 200, TIFTON, GA 31793  
 ST. LOUIS MO 63114 ATTN: MR. TODD BUCKNER

## BUILDING REQUIREMENTS

- A MINIMUM OF THIRTY-FIVE (35%) OPENSPACE FOR EACH LOT.
- A MAXIMUM F.A.R. OF 0.55 FOR THIS PC DISTRICT

## HEIGHT:

- MAX HEIGHT INCLUDING PARAPETS AND ROOFTOP EQUIPMENT OF ALL BUILDINGS SHALL NOT EXCEED FORTY-TWO (42) FEET.
- ALL BUILDINGS WITHIN THIS DEVELOPMENT SHALL BE LIMITED TO TWO (2) STORY CONSTRUCTION

## STRUCTURE SETBACKS:

- THIRTY (30) FEET FROM THE SOUTHERN BOUNDARY OF THIS PC DISTRICT THAT FRONTS ON CHESTERFIELD AIRPORT ROAD.
- FIFTY-FIVE (55) FEET FROM THE NORTHERN BOUNDARY OF THIS PC DISTRICT THAT FRONT 1-64/US 40.
- TEN (10) FEET FROM ALL OTHER BOUNDARY LINES WITHIN THIS PC DISTRICT

## PARKING SETBACKS:

- THIRTY (30) FEET FROM THE SOUTHERN BOUNDARY OF THIS PC DISTRICT THAT FRONTS ON CHESTERFIELD AIRPORT ROAD.
- FIFTY-FIVE (55) FEET FROM THE NORTHERN BOUNDARY OF THIS PC DISTRICT THAT FRONT 1-64/US 40.
- ZERO (0) FEET FROM ALL OTHER BOUNDARY LINES WITHIN THIS PC DISTRICT

## PARKING CALCULATIONS

REQUIRED PARKING [PER SECTION 405.04.040(D)]  
 NUMBER OF EMPLOYEES ON MAX SHIFT = 4 EMPLOYEES  
 MINIMUM CAR WASH: 2 SPACES FOR EVERY 3 EMPLOYEES ON THE MAX SHIFT  
 MIN. REQUIRED: 4 EMPLOYEES x (2 SPACES/3 EMPLOYEES) = 2.67 OR 3 SPACES

## MAXIMUM

CAR WASH: 1.2 SPACES PER EMPLOYEE ON THE MAXIMUM SHIFT  
 MAX. REQUIRED: 4 EMPLOYEES x (1.2 SPACES) = 4.8 OR 5 SPACES  
 TOTAL PROVIDED: 5 EMPLOYEE SPACES

## OPENSACE CALCULATIONS

TOTAL SITE AREA: 60,627 S.F.  
 BUILDING/CANOPY/PAYSTATION: 5,396 S.F.  
 VEHICLE PAVEMENT: 28,048 S.F.  
 (EXCLUDES AREA UNDER CANOPY/PAYSTATION)  
 PERCENT OPENSACE: 60,627-5,396-28,048 = 27,183 OR 44.84%

## ST. LOUIS COUNTY STANDARD NOTES

- ALL PROPOSED IMPROVEMENTS SHALL BE CONSTRUCTED TO ST. LOUIS COUNTY STANDARDS.
- NO SLOPES SHALL EXCEED 3 (HORIZONTAL) TO 1 (VERTICAL) WITHIN ST. LOUIS COUNTY RIGHT-OF-WAY UNLESS JUSTIFIED BY A GEOTECHNICAL REPORT, WHICH HAS BEEN APPROVED BY ST. LOUIS COUNTY, AND DESIGNED IN FULL COMPLIANCE WITH ROADSIDE SAFETY STANDARDS.
- STORM WATER SHALL BE DISCHARGED AT AN ADEQUATE NATURAL DISCHARGE POINT. SINKHOLES ARE NOT ADEQUATE DISCHARGE POINTS.
- ALL PROPOSED ACCESS TO ST. LOUIS COUNTY ROADS SHALL MEET MINIMUM ST. LOUIS COUNTY SIGHT DISTANCE REQUIREMENTS.
- ALL GRADING AND DRAINAGE SHALL BE IN CONFORMANCE WITH ST. LOUIS COUNTY AND MSD STANDARDS.
- ALL ABOVE-GROUND UTILITIES OR OTHER POTENTIAL OBSTRUCTIONS WITHIN THE ST. LOUIS COUNTY ROAD RIGHT-OF-WAY, SHALL HAVE A MINIMUM SETBACK, AS DIRECTED BY THE ST. LOUIS COUNTY DEPARTMENT OF TRANSPORTATION, AS PRESCRIBED IN SECTION 5.10 OF THE ST. LOUIS COUNTY DESIGN CRITERIA MANUAL "ROADSIDE DESIGN REQUIREMENTS"
- ANY ENTITY THAT PERFORMS WORK ON ST. LOUIS COUNTY MAINTAINED PROPERTY SHALL PROVIDE THE COUNTY WITH A CERTIFICATE OF INSURANCE EVIDENCING GENERAL LIABILITY COVERAGE (BODILY INJURY AND PROPERTY DAMAGE) IN THE AMOUNTS SPECIFIED AS THE LIMITS OF LIABILITY SET BY THE STATE FOR PUBLIC ENTITIES. SUCH CERTIFICATE SHALL INCLUDE ST. LOUIS COUNTY AS AN ADDITIONAL INSURED AND SHALL BE PROVIDED PRIOR TO THE ISSUANCE OF ANY PERMIT. CERTIFICATE SHALL PROVIDE FOR A 30 DAY POLICY CANCELLATION NOTICE TO ST. LOUIS COUNTY. UPON REQUEST, THE COUNTY WILL PROVIDE THE SPECIFIC AMOUNTS FOR BOTH PER PERSON AND PER OCCURRENCE LIMITS.
- PRIOR TO SPECIAL USE PERMIT ISSUANCE BY THE ST. LOUIS COUNTY DEPARTMENT OF HIGHWAYS AND TRAFFIC, A SPECIAL CASH ESROW OR A SPECIAL ESROW SUPPORTED BY AN IRREVOCABLE LETTER OF CREDIT, MAY BE REQUIRED TO BE ESTABLISHED WITH THE ST. LOUIS COUNTY DEPARTMENT OF HIGHWAYS AND TRAFFIC TO GUARANTEE COMPLETION OF THE REQUIRED ROADWAY IMPROVEMENTS.
- TRAFFIC GENERATION ASSESSMENT CONTRIBUTIONS FOR ROADWAY IMPROVEMENTS AND STORM WATER SHALL BE ASSESSED WITH EACH SITE DEVELOPMENT SECTION PLAN SUBMITTAL. WATER MAIN CONTRIBUTION SHALL BE ASSESSED AND PAID FOR THE ENTIRE DEVELOPMENT PRIOR TO THE ST. LOUIS COUNTY APPROVAL OF THE SITE DEVELOPMENT CONCEPT PLAN. TGA CONTRIBUTION FOR STORM WATER WILL BE DUE PRIOR TO BUILDING PERMITS ISSUED BY ST. LOUIS COUNTY DEPARTMENT OF PUBLIC WORKS.

## GRAPHIC SCALE



## SCRUBBLES EXPRESS WASH CHESTERFIELD AIRPORT ROAD, LLC

SCRUBBLES EXPRESS WASH CHESTERFIELD AIRPORT ROAD, LLC, the owner of the property shown on this plan for and in consideration of being granted a permit to develop property under the provisions of Chapter "PC" (Present zoning) of the City of Chesterfield Ordinance No. 3206, do hereby agree and declare that said property from the date of recording this plan shall be developed only as shown thereon, unless said plan is amended by the Planning Commission, or voided or vacated by order of ordinance of the City of Chesterfield Council.

## SCRUBBLES EXPRESS WASH CHESTERFIELD AIRPORT ROAD, LLC

By: Justin Wynn, AICP, Director of Planning City of Chesterfield, Missouri  
 By: Vickie McGowan, City Clerk City of Chesterfield, Missouri  
 On this day of \_\_\_\_\_, 2023, before me personally appeared \_\_\_\_\_, who being by me duly sworn, did say he is the \_\_\_\_\_ and that said instrument was signed on behalf of said limited liability company, and that said \_\_\_\_\_ acknowledged said instrument to be the free act and deed of said limited liability company.  
 IN WITNESS WHEREOF, I have signed and sealed the foregoing the day and year first above written.  
 Notary Public  
 My commission expires: \_\_\_\_\_  
 Print Name  
 My commission expires: \_\_\_\_\_

## SURVEYOR'S CERTIFICATION

This is to certify that Stock & Associates Consulting Engineers, Inc. has prepared this Amended Site Development Section Plan from a field survey and does not represent a property boundary survey. The information shown is a correct representation of all existing and proposed land divisions.  
 ST. LOUIS AND ASSOCIATES CONSULTING ENGINEERS, INC.  
 L.S. No. 222-D  
 Walter J Pfeifer, Missouri L.S. No. 2008000728

## WALL PROFILE

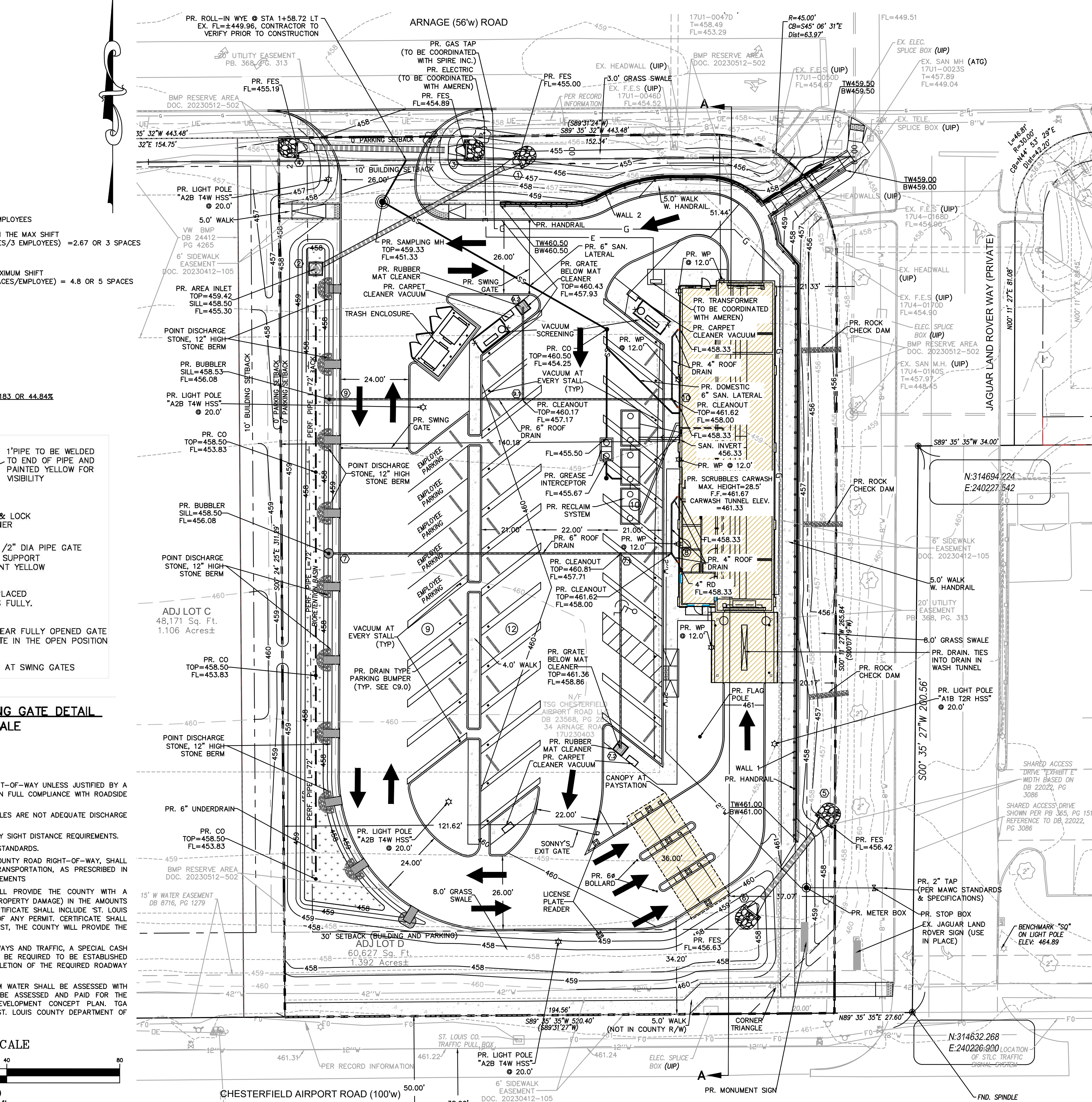
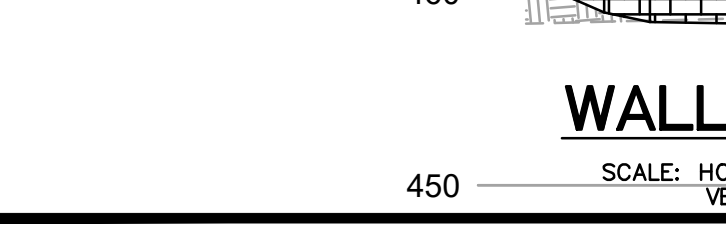

## SKY EXPOSURE PROFILE

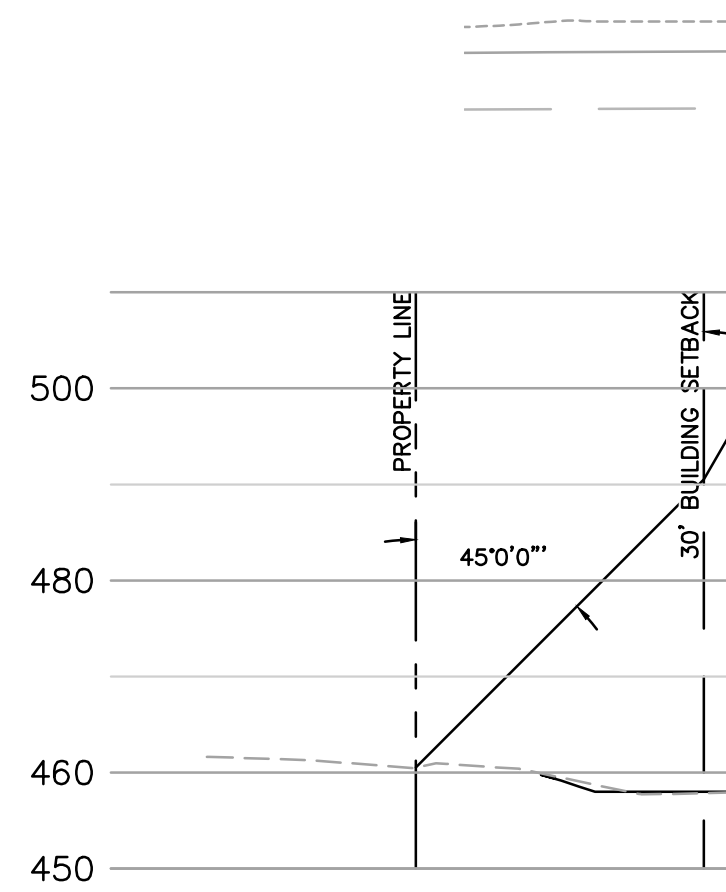

## WALL 1 PROFILE

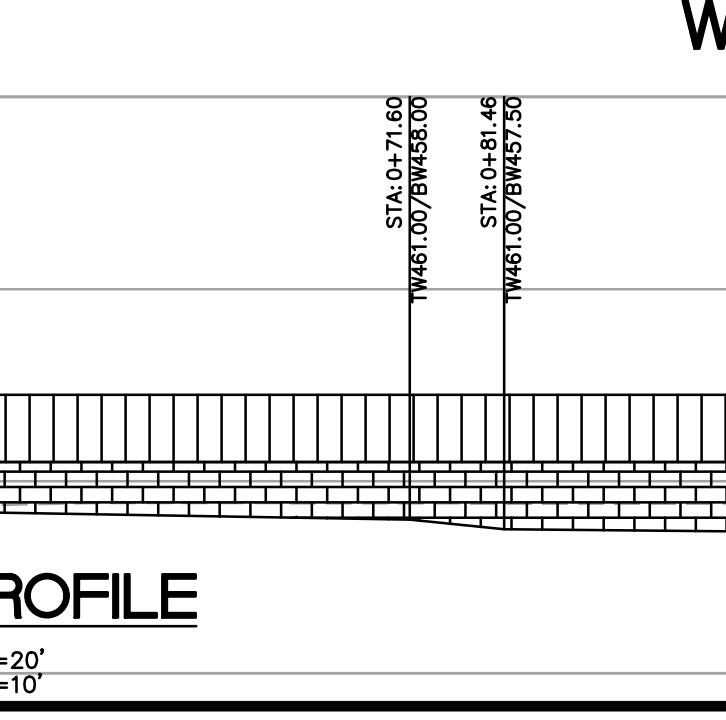

## WALL 2 PROFILE

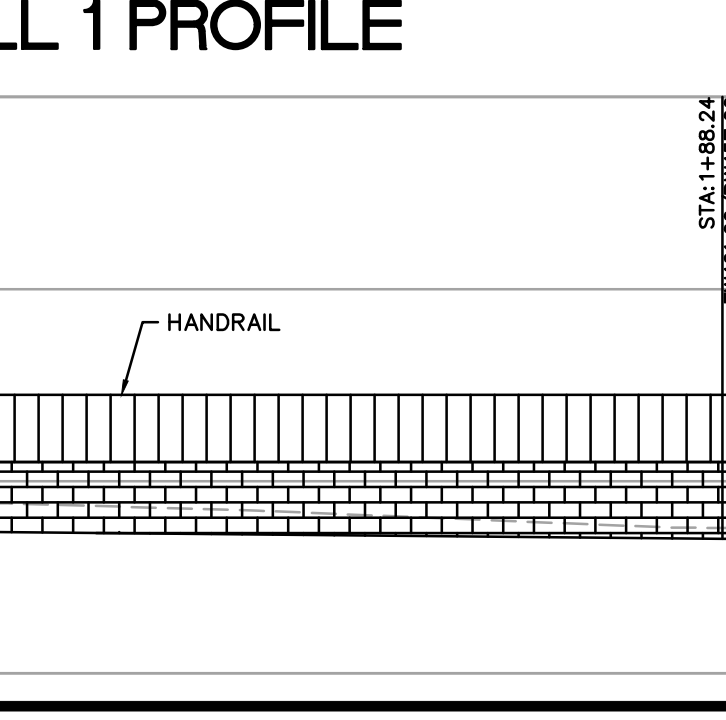

267 Chesterfield Business Parkway  
 St. Louis, MO 63005 PH: (636) 500-9000 FAX: (636) 530-9000  
 e-mail: general@stockandassociates.com  
 Web: www.stockandassociates.com

PREPARED BY: STOCK & ASSOCIATES Consulting Engineers, Inc.

AMENDED SITE DEVELOPMENT SECTION PLAN FOR: SCRUBBLES CARWASH

34 ARNAGE ROAD CHESTERFIELD, MISSOURI

REVISIONS:

1. 2023-06-29 CITY

GEORGE M. STOCK E-2516  
 CIVIL ENGINEER  
 CERTIFICATE OF AUTHORITY  
 NUMBER: 00099

DATE: 6/12/2023

JOB NO.: 2022-7330

S.D.P. # \_\_\_\_\_

DATE: 6/12/2023

S.D.P. # \_\_\_\_\_

DATE: 6/12/2023

S.D.P. # \_\_\_\_\_

DATE: 6/12/2023

S.D.P. # \_\_\_\_\_

DATE: 6/12/2023

S.D.P. # \_\_\_\_\_

DATE: 6/12/2023

S.D.P. # \_\_\_\_\_

DATE: 6/12/2023

S.D.P. # \_\_\_\_\_

DATE: 6/12/2023

S.D.P. # \_\_\_\_\_

DATE: 6/12/2023

S.D.P. # \_\_\_\_\_

DATE: 6/12/2023

S.D.P. # \_\_\_\_\_

DATE: 6/12/2023

S.D.P. # \_\_\_\_\_

DATE: 6/12/2023

S.D.P. # \_\_\_\_\_

DATE: 6/12/2023

S.D.P. # \_\_\_\_\_

DATE: 6/12/2023

S.D.P. # \_\_\_\_\_

DATE: 6/12/2023

S.D.P. # \_\_\_\_\_

DATE: 6/12/2023

S.D.P. # \_\_\_\_\_

DATE: 6/12/2023

S.D.P. # \_\_\_\_\_

DATE: 6/12/2023

S.D.P. # \_\_\_\_\_

DATE: 6/12/2023

S.D.P. # \_\_\_\_\_

DATE: 6/12/2023

S.D.P. # \_\_\_\_\_

DATE: 6/12/2023

S.D.P. # \_\_\_\_\_

DATE: 6/12/2023

S.D.P. # \_\_\_\_\_

DATE: 6/12/2023

S.D.P. # \_\_\_\_\_



### Schedule

Symbol	Label	Quantity	Manufacturer	Catalog Number	Description	Filename	Lumen Multiplier	Light Loss Factor	Total Lamp Lumens	Wattage	Plot
	A1B T2R HSS	1	Lithonia Lighting	RSX2 LED P1 40K R2 MVOLT HS SPA DDBXD	RSX LED Area Luminaire Size 2 P1 Lumen Package 4000K CCT Type R2 Distribution with HS shield	RSX2_LED_P1_40K_R2_HS.ies	1	0.9	8340	72.06	
	A2B T4W HSS	4	Lithonia Lighting	RSX2 LED P3 40K R4 MVOLT HS SPA DDBXD	RSX Area Fixture Size 2 P3 Lumen Package 4000K CCT Type R4 Distribution with HS Shield	RSX2_LED_P3_40K_R4_HS.ies	1	0.9	15334	149.9762	
	B	22	G&G Industrial Lighting	GPX4-SO	Driverless AC LED Luminaire	GPX4-SO.IES	1	0.9	2400	18	
	WP	5	Lithonia Lighting	WDGE1 LED P2 40K 80CRI VF MVOLT SRM DDBXD	WDGE1 LED WITH P2 - PERFORMANCE PACKAGE, 4000K, 80CRI, VISUAL COMFORT FORWARD OPTIC	WDGE1_LED_P2_40K_80CRI_VF.ies	1	0.9	1978	15.0178	

### Statistics

Description	Symbol	Avg	Max	Min	Max/Min	Avg/Min
SITE	+	2.8 fc	8.0 fc	0.1 fc	80.0:1	28.0:1
.PROPERTY LINE	+	0.3 fc	4.9 fc	0.0 fc	N/A	N/A

**Note**  
 - MEASUREMENTS TAKEN @ GROUND LEVEL  
 - MOUNTING HEIGHT NOTED ON EACH FIXTURE

**Plan View**  
 Scale - 1" = 14ft

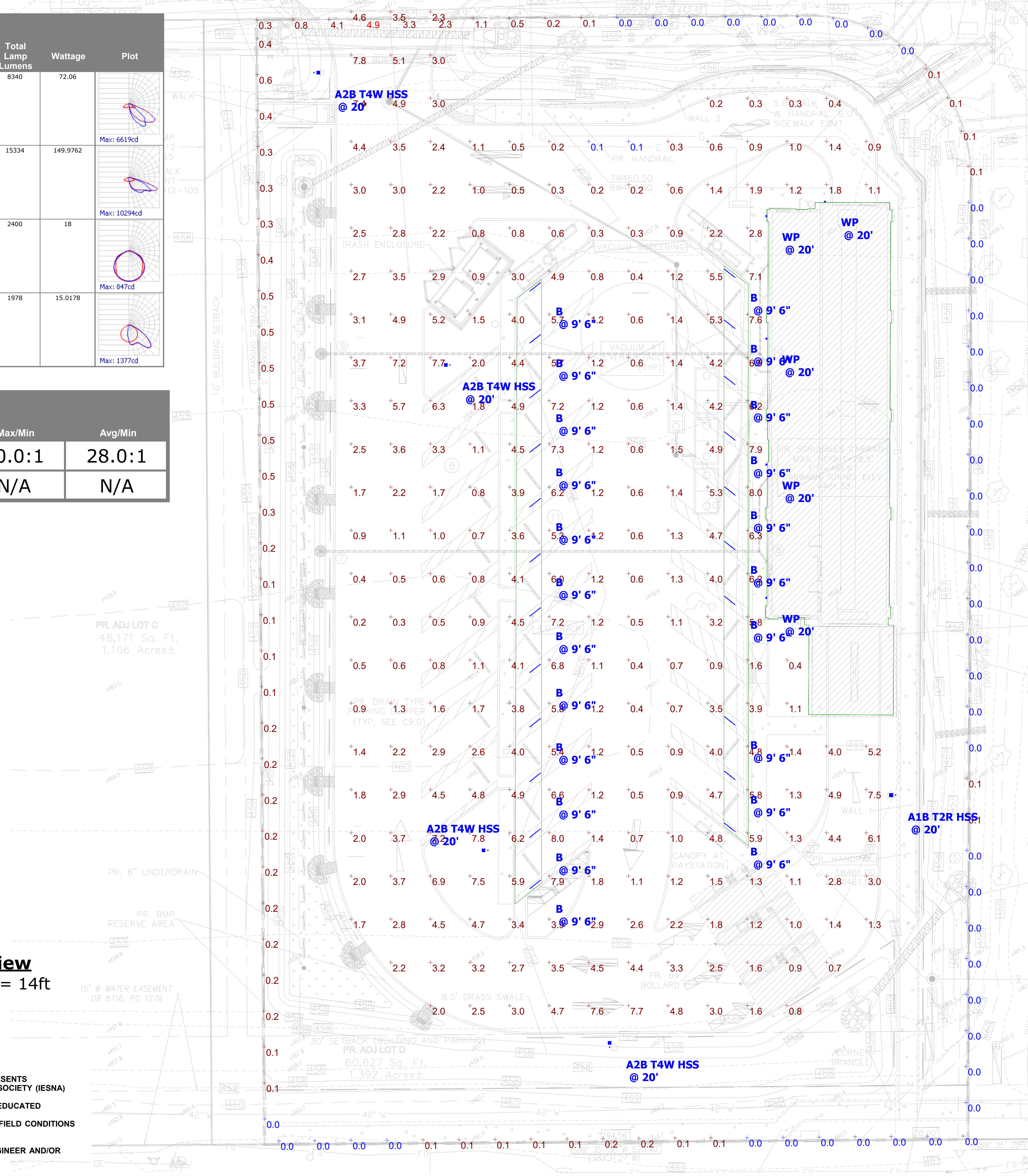

**DESIGNER'S NOTE:**  
 THE ENGINEER AND/OR ARCHITECT MUST DETERMINE APPLICABILITY OF THE LAYOUT TO EXISTING / FUTURE FIELD CONDITIONS. THIS LIGHTING LAYOUT REPRESENTS ILLUMINATION LEVELS CALCULATED FROM LABORATORY DATA TAKEN UNDER CONTROLLED CONDITIONS IN ACCORDANCE WITH ILLUMINATING ENGINEERING SOCIETY (IESNA) APPROVED METHODS. ADDITIONALLY, THE PREPARER USED INFORMATION PROVIDED BY THE CUSTOMER. IF/WHEN SUFFICIENT INFORMATION WAS NOT PROVIDED, PREPARER USED EDUCATED ASSUMPTIONS. ACTUAL PERFORMANCE OF ANY MANUFACTURER'S LUMINAIRE(S) MAY VARY DUE TO VARIATION IN ELECTRICAL VOLTAGE, TOLERANCE IN LAMPS, AND OTHER FIELD CONDITIONS NOT ACCOUNTED FOR IN THIS PHOTOMETRIC ANALYSIS.  
 THESE LIGHTING CALCULATIONS ARE NOT A SUBSTITUTE FOR INDEPENDENT ENGINEERING ANALYSIS OF LIGHTING SYSTEM SUITABILITY AND SAFETY. THE ENGINEER AND/OR ARCHITECT IS RESPONSIBLE TO REVIEW FOR ENERGY CODE AND RELEVANT LIGHTING QUALITY COMPLIANCE.

**SCRUBBLES CHESTERFIELD**



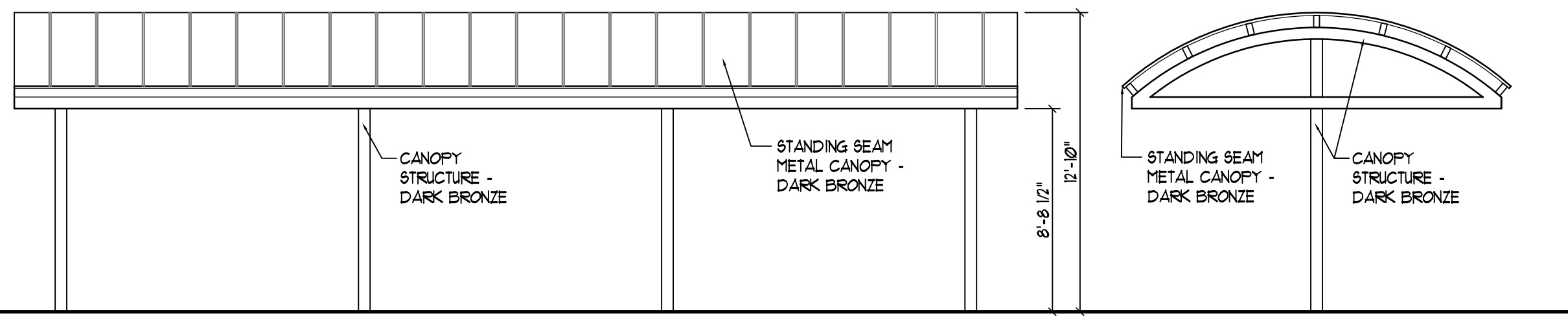

**PAY STATION CANOPY ELEVATIONS**  
SCALE: 3/16" = 1'-0"

**ELEVATION NOTES:**

- IF INTEGRAL BLOCK AND MORTAR SEALER IS NOT FURNISHED PROVIDE ALTERNATE BID TO SEAL THE EXTERIOR MASONRY WALLS W/ SILICONE CLEAR SEALER OR EQUAL.

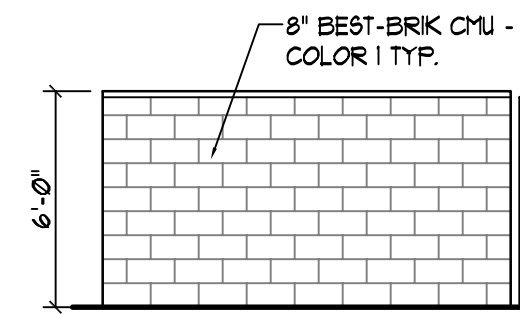
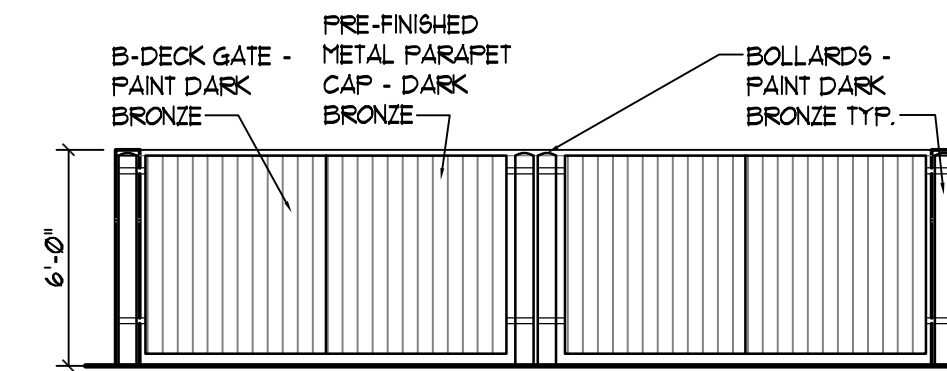

**TRASH ENCLOSURE ELEVATIONS**  
SCALE: 3/16" = 1'-0" (23'-4" X 11'-4" ENCLOSURE)

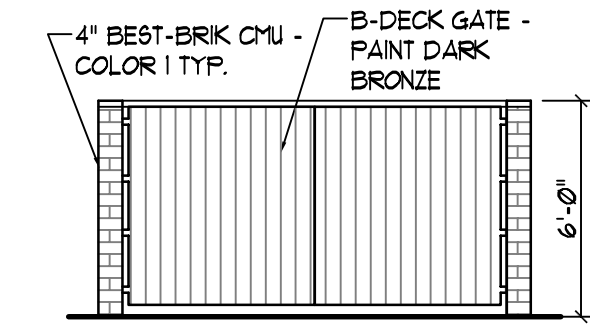

**VACUUM SCREENING**  
SCALE: 3/16" = 1'-0" (12'-0" X 6'-4" ENCLOSURE)

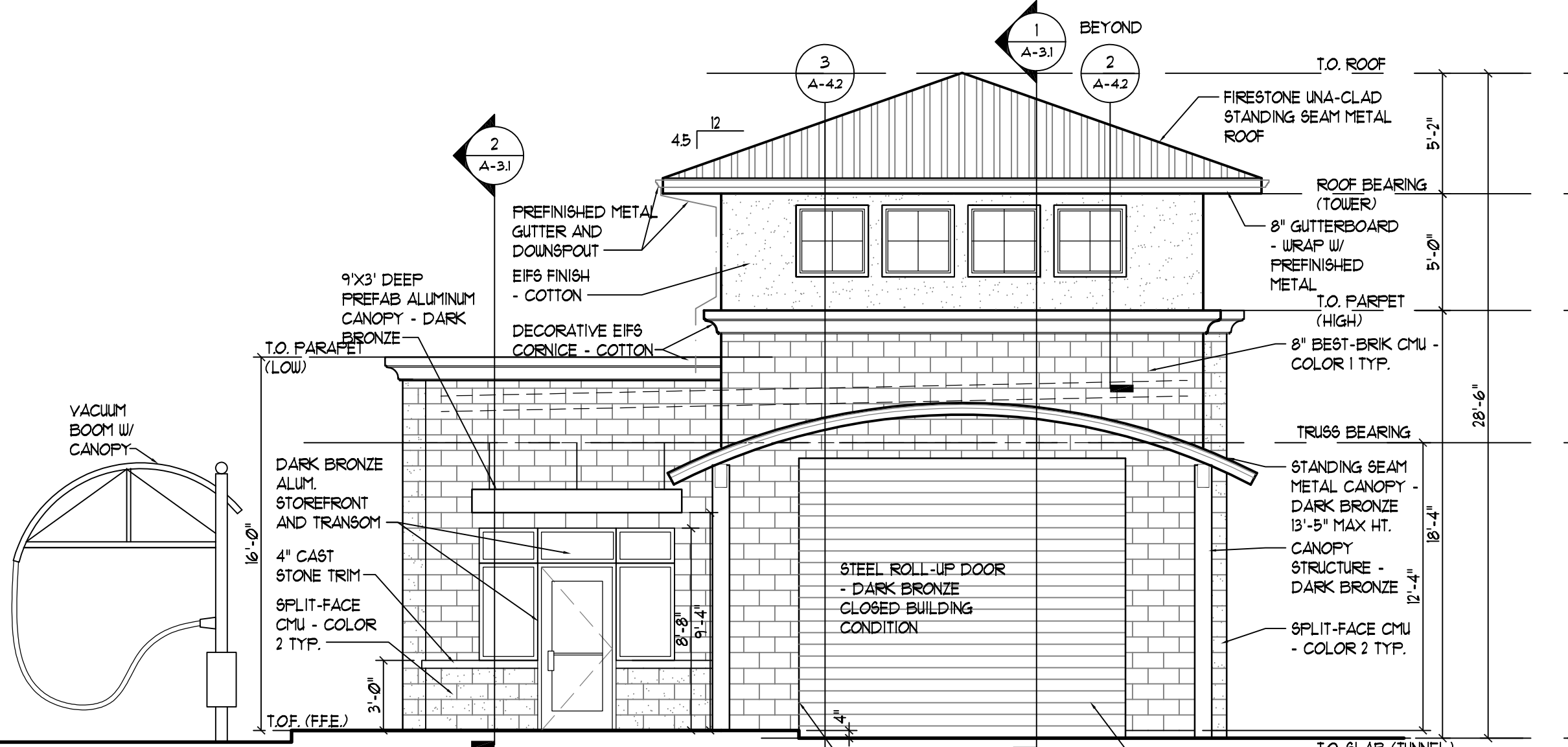

**SOUTH ELEVATION**  
SCALE: 3/16" = 1'-0"

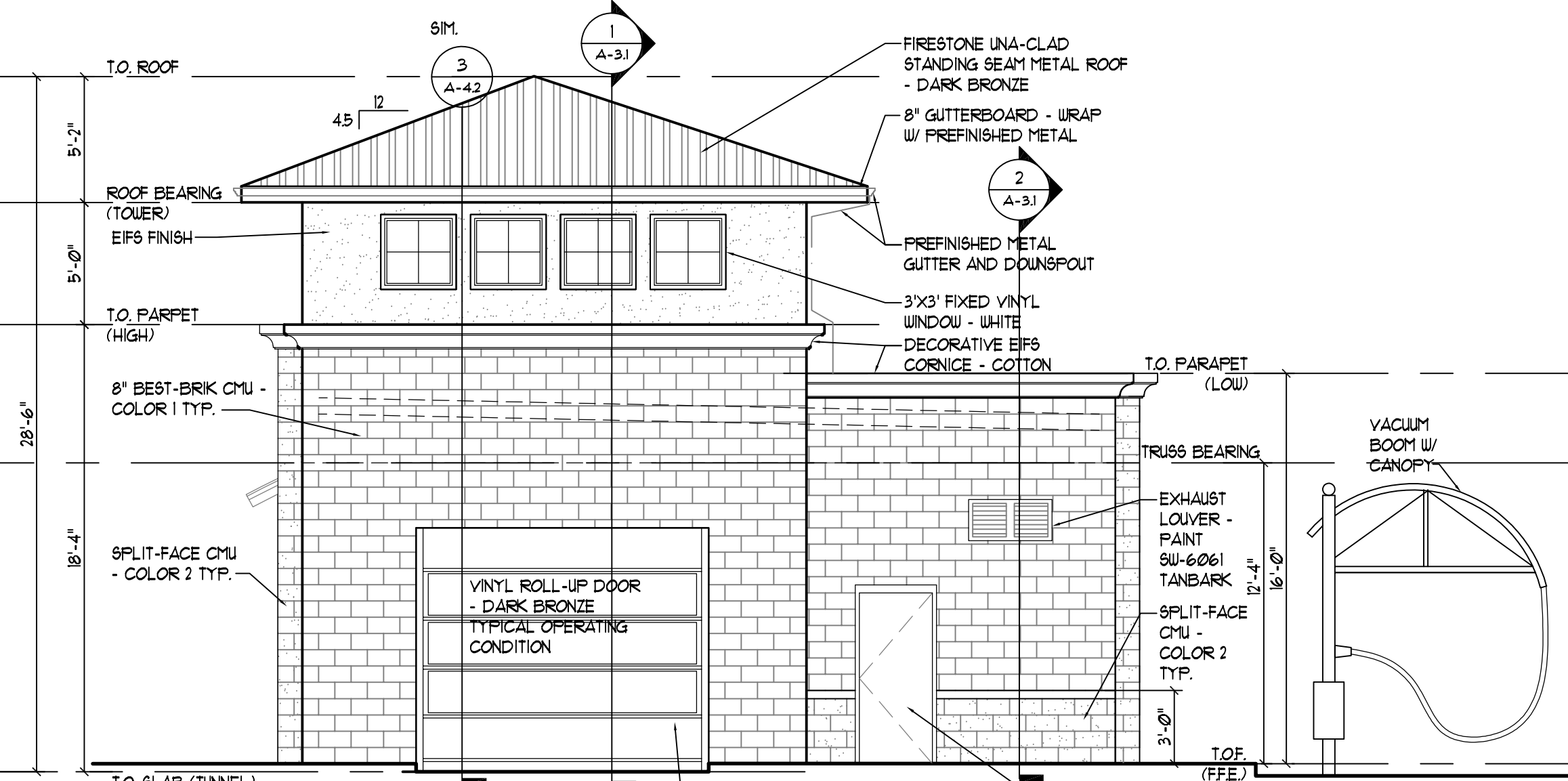

**NORTH ELEVATION**  
SCALE: 3/16" = 1'-0"

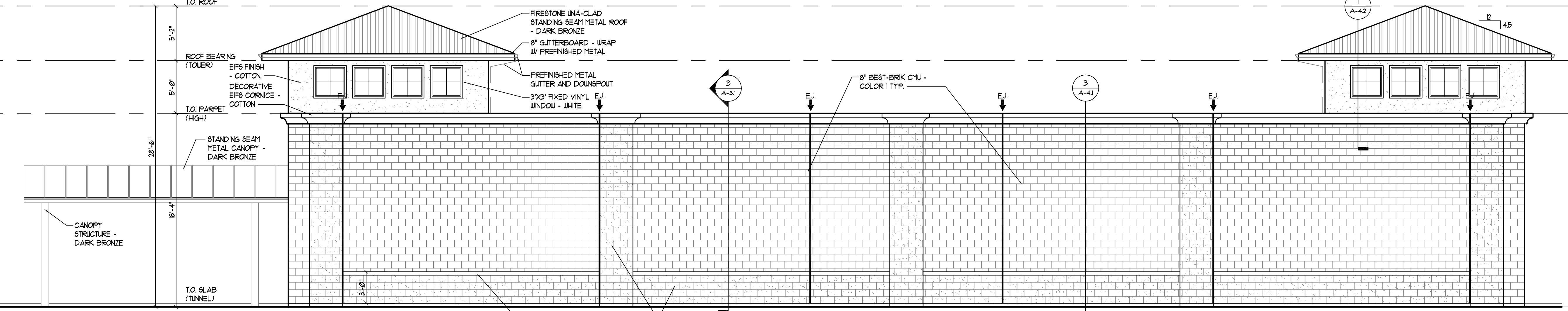

**EAST ELEVATION**  
SCALE: 3/16" = 1'-0"

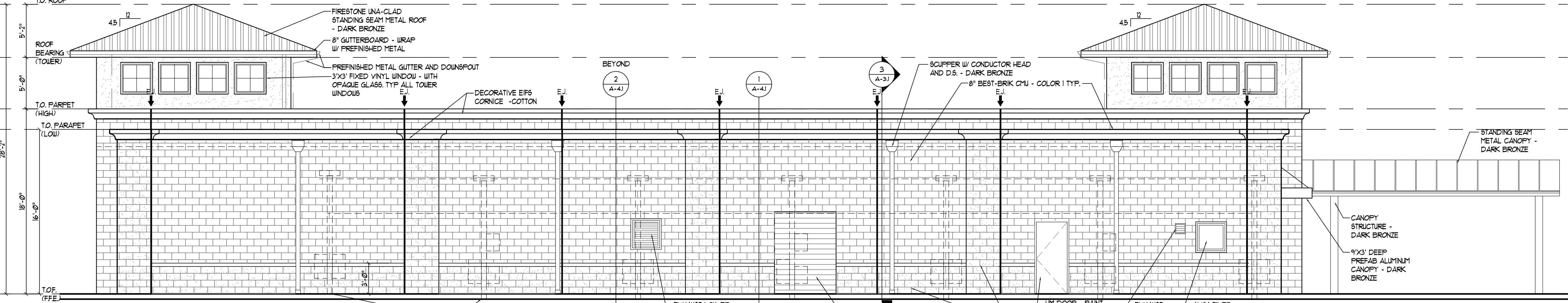

**WEST ELEVATION**  
SCALE: 3/16" = 1'-0"

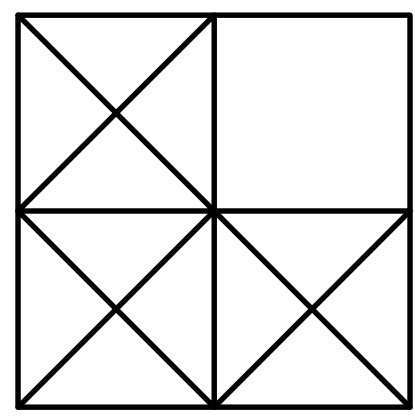

**LEVINE**  
*associates*  
architecture · interiors · planning  
2025 South Brentwood Boulevard, Suite 101  
Saint Louis, Missouri 63144  
Phone 314-991-6500

ARCHITECT: ALYAH M. LEVINE  
NO. LICENSE A-4249  
ALYAH M. LEVINE, INC.  
DBA LEVINE ASSOCIATES  
CERTIFICATE OF AUTHORITY  
LICENSE NUMBER A-2018040328

**elevations**  
NEW BUILDING FOR: SCRUBBLES CAR WASH  
34 ARNAGE ROAD  
CHESTERFIELD, MISSOURI 63005  
CONTRACTOR: CISELL MUELLER CONSTRUCTION, INC.

**REVISIONS**

NO.	DATE	ITEM
1	6-21-23	ARB
2	7-25-23	PERRIT SET

SHEET NO.  
**A-21**

ISSUE DATE: 6-5-23  
PROJECT #: 2293.02  
DRN, CMC, CHK, AML