



---

690 Chesterfield Pkwy W • Chesterfield MO 63017-0760  
Phone: 636-537-4000 • Fax 636-537-4798 • [www.chesterfield.mo.us](http://www.chesterfield.mo.us)

---

## Planning Commission Staff Report

**Meeting Date:** June 14, 2021

**From:** Mike Knight, Assistant City Planner

**Location:** City of Chesterfield

**Petition:** **P.Z. 01-2021 City of Chesterfield (Unified Development Code—Article 4 and Article 10):** An ordinance amending Article 4 and Article 10 of the Unified Development Code to revise regulations pertaining to window signs.

### **SUMMARY**

The Unified Development Code (UDC) was approved and adopted by the City of Chesterfield City Council in June of 2014. The purpose of this petition is to discuss and potentially revise these regulations where they pertain to window signs in Article 4, Section 405.04.050 *Sign Requirements* and the associated definition of a window sign in Article 10, Section 405.10.040 *Signage Terms*.

This petition is the result of a request, received by the Planning and Public Works Committee at the February 18, 2021 meeting, to review window signage. The Committee formally directed staff to review the current regulations of window signage. The Committee identified potential concerns and directed staff to research the current regulations, as well as bring forward potential updates to the window sign requirements within the City's Unified Development Code.

The Unified Development Code defines a purpose for sign requirements within the City of Chesterfield. This is an opportunity for the Planning Commission to review the current and potential future regulations for window signs and identify whether this language is in line with the purpose of the overall sign requirements for the city.

A Public Hearing was held on March 22, 2021. At that meeting a few items were brought up by the Commission for staff to research, clarify and bring back before the Planning Commission.

On April 26<sup>th</sup>, staff brought forward the information and clarification the Commission requested. After dialogue over the potential revisions, the Commission directed staff to move towards a

calculation of allowable window signage based on window area vs a finite amount of signs within individual windows.

The following report focuses on new language brought forward by staff from the direction at the April Planning Commission meeting. Attached to this report is the April Staff report which details items such as the history of window signage, research performed, and Public Hearing input. After a vote is taken by the Planning Commission, this project will be presented before the Planning and Public Works Committee for a recommendation to the City Council.

### **REQUEST**

At the February 18<sup>th</sup>, 2021 Planning and Public Works Committee meeting, a Window Sign discussion was included in new business. Following the discussion, the Committee formally directed staff to review the current regulations of window signage and address concerns from City Council. There are two primary concerns. The first concern is that window signs are currently permitted on multiple floors of buildings, in which some office buildings consist mostly of glass windows. The second concern is that unlike monument and wall signs, there is no maximum allowed amount of window signs, and thus every window of a building could be covered under the current allowable percentage.

### **PURPOSE**

Section 405.04.050 of the City of Chesterfield Unified Development Code identifies the purpose of sign regulations for the City. The purpose is separated into two parts and transcribed below.

- 1. The purpose of the sign regulations provided herein is to encourage excellence in design of signs, fostering economic viability of the community, and provide safe and concise directional information designed to facilitate traffic flow. Signs shall be designed so as to protect motorists, bicyclists, and pedestrians from distractions that may cause crashes or other detrimental impacts.*
- 2. Signs shall not overload the public's capacity to receive information or cause visual confusion by interfering with pedestrian or vehicular traffic. Signs shall conform to the character of the community, enhance the visual harmony of development, and preserve the public health, convenience, welfare and/or safety within the City of Chesterfield by maintaining the high aesthetic quality of the community.*

### **RECOMMENDATION**

The first concern of the Planning and Public Works Committee is that window signs are currently permitted on multiple floors of buildings. The Unified Development Code states that window

signs may be placed on any window in addition to other permitted signs. The outline area of said signs, whether temporary or permanent, shall occupy no more than (40%) of the outline area of any window on the ground or first floor level of the building and no more (20%) of any window on any other level of the building.

Currently there are very few window signs above the first floor of buildings. Although it may be unlikely in the current environment of Chesterfield, if a building did utilize window signs on a high floor, it could easily conflict with the Purpose delineated in our code, specifically conforming to the character of the community and not overloading the public's capacity to receive information.

A minor adjustment to the code could be made to alleviate the concern. Staff proposes to remove the language referencing other levels, solely permitting window signs on the first floor and second floor of a building. Currently there are not many, if any, businesses that have window signs above the first floor and none known above the second. Although this may have minimal impact on the current conditions, it will prevent a full glass office building from having numerous signs on numerous tenant floors above the first and second level. This alleviates one of the primary concerns of the Planning and Public Works Committee.

The second concern is that there is no maximum on the total number of window signs. A few alternatives to abate this concern were proposed by staff within the March and April 2021 Planning Commission meetings. Ultimately the Planning Commission expressed the desire to move forward with calculating Window Signage by a defined window area vs a single window. Staff researched other municipalities using this metric for window signage and found that a common percentage when utilizing this metric is 20% of a window area. This form of sign allocation guarantees each ground floor or second floor tenant an opportunity to have a window sign, assuming they have a window.

Below is a red-line version of the Unified Development Code incorporating the recommendations above.

Section 405.04.050 G.2.f.

#### Window Signs.

1) Window Signs shall not occupy more than twenty percent (20%) of any single window area. The window area may include multiple panes of glass separated only by supporting framing materials but not separated by architectural elements. Further, glass located within a door, whether or not it is used as an entrance/exit, is not an eligible location for a window sign.

2) Window Signs are solely permitted on the first and second floor of a building.

**3) A sign permit shall not be required for any window sign.**

It is important to note that when considering the regulations of window signs, items such as hours of operation, open/closed, and other messages that cannot be understood from a position off-site are considered “incidental” and are exempt signs in the City’s Unified Development Code.

It is also important to note that the City of Chesterfield approved Ordinance 3124. This Ordinance acknowledges the economic impact on business due to the COVID 19 pandemic and allows the reasonable temporary suspension for various development criteria including regulation on temporary signs. The potential updates to code would in no way prohibit or retract from the intent of Ordinance 3124.

Staff also recommends a minor change to the definition of a window sign in Article 10 of the City’s Unified Development Code for clarification purposes. The draft red-line change is shown below.

Section 405.10.040 Signage Terms.

**SIGN, WINDOW**

**A sign placed on the surface of a window or other transparent surface and is visible from the exterior of the window or surface.**

The changes herein are recommended by Staff in order to effectively administer the UDC as originally intended and to implement revised language as directed by the Planning and Public Works Committee. A Public Hearing was held on March 22<sup>nd</sup>, 2021 as an opportunity for Staff to communicate the current regulations on Window Signs, give an opportunity for the public to provide input, and for the Planning Commission to review the current and potentially future regulations and identify whether this language is in line with the purpose of the overall sign requirements for the city. After a vote is taken by the Planning Commission, this project will be presented before the Planning and Public Works Committee for a recommendation to the City Council.

**Staff is requesting that the Planning Commission vote on these amendments in order for them to move forward to the Planning and Public Works Committee.**

Attachments:

1. April 26, 2021 Planning Commission Staff Report
2. Proposed Red-Line Changes



---

690 Chesterfield Pkwy W • Chesterfield MO 63017-0760  
Phone: 636-537-4000 • Fax 636-537-4798 • [www.chesterfield.mo.us](http://www.chesterfield.mo.us)

---

## Planning Commission Staff Report

**Meeting Date:** April 26, 2021

**From:** Mike Knight, Assistant City Planner

**Location:** City of Chesterfield

**Petition:** **P.Z. 01-2021 City of Chesterfield (Unified Development Code—Article 4 and Article 10):** An ordinance amending Article 4 and Article 10 of the Unified Development Code to revise regulations pertaining to window signs.

### **SUMMARY**

The Unified Development Code (UDC) was approved and adopted by the City of Chesterfield City Council in June of 2014. The purpose of this petition is to discuss and potentially revise these regulations where they pertain to window signs in Article 4, Section 405.04.050 *Sign Requirements* and the associated definition of a window sign in Article 10, Section 405.10.040 *Signage Terms*.

This petition is the result of a request, received by the Planning and Public Works Committee at the February 18, 2021 meeting, to review window signage. The Committee formally directed staff to review the current regulation of window signage. The Committee identified potential concerns and directed staff to research the current regulations, as well as bring forward potential updates to the window sign requirements within the City's Unified Development Code.

The Unified Development Code defines a purpose for sign requirements within the City of Chesterfield. This is an opportunity for the Planning Commission to review the current and potential future regulations for window signs and identify whether this language is in line with the purpose of the overall sign requirements for the city.

A Public Hearing was held on March 22, 2021. At that meeting a few items were brought up by the Commission for staff to research, clarify and bring back before the Planning Commission. The following report details those items brought forward at the Public Hearing. After a vote is taken by the Planning Commission, this project will be presented before the Planning and Public Works Committee for a recommendation to the City Council.

## **HISTORY**

Window signs are currently permitted and have been permitted since before the City was incorporated. The table below outlines a history of window sign regulations in the City of Chesterfield. The window sign regulation has been largely consistent, with minor amendments, most notably a 10% decrease in signage outline area allowed per window in 1997. It is important to note the dates outlined within the “Historical Reference” column below are not a singular point in time, but an estimated time period based on research of both previous zoning ordinance and the City’s Unified Development Code.

Historical Reference	Window Sign Regulation
Pre-1988 -1997 Zoning Ordinance	Signs may be placed on any window in addition to other permitted signs. However, the outline area of the signs shall occupy no more than 50% of the outline area of any window on the ground floor and no more than 20% of any window on any other level of the building.
1997 Zoning Ordinance - Present Unified Development Code	Window signs may be placed on any window in addition to other permitted signs. However, the outline area of said signs, whether temporary or permanent, shall occupy no more than (40%) of the outline area of any window on the ground or first floor level of the building and no more (20%) of any window on any other level of the building. A sign permit shall not be required for any window sign.

*Table 1: Historical Regulation*

## **REQUEST**

At the February 18<sup>th</sup>, 2021 Planning and Public Works Committee meeting, a Window Sign discussion was included in new business. Following the discussion, the Committee formally directed staff to review the current regulation of window signage and address concerns from City Council. There are two primary concerns. The first concern is that window signs are currently permitted on multiple floors of buildings, in which some office buildings consist mostly of glass windows. The second concern is that unlike monument and wall signs, there is no maximum allowed amount of window signs, and thus every window of a building could be covered under the current allowable percentage (Table 1).

## **PURPOSE**

Section 405.04.050 of the City of Chesterfield Unified Development Code identifies the purpose of sign regulations for the City. The purpose is separated into two parts and transcribed below.

- 1. The purpose of the sign regulations provided herein is to encourage excellence in design of signs, fostering economic viability of the community, and provide safe and concise directional information designed to facilitate traffic flow. Signs shall be designed so as to protect motorists, bicyclists, and pedestrians from distractions that may cause crashes or other detrimental impacts.*
- 2. Signs shall not overload the public's capacity to receive information or cause visual confusion by interfering with pedestrian or vehicular traffic. Signs shall conform to the character of the community, enhance the visual harmony of development, and preserve the public health, convenience, welfare and/or safety within the City of Chesterfield by maintaining the high aesthetic quality of the community.*

## **RESEARCH**

In accordance with the request by the Planning and Public Works Committee, staff reviewed the window signage regulations of a number of surrounding municipalities. Additionally, staff spoke to Planners in surrounding municipalities about review and enforcement of window signage, and also discussed the topic of window signage with nearby sign companies. After this thorough review, it was determined that window sign regulation varies widely between each municipality. In some cases, no additional signage is allocated for windows, while some are only approved for a temporary length in time, and in other cases, it is a percentage of the total window area of a façade vs. an individual window. The City of Chesterfield regulations were not unique, but there is a definite lack of consistency about window signage regulation between municipalities.

In anticipation of the Public Hearing scheduled for March 22<sup>nd</sup>, 2021, staff brought the items/concerns forward to Planning Commission on March 8<sup>th</sup>, 2021 for discussion purposes. During discussion, the Commission asked how the current window signage regulations are being upheld around town. It was acknowledged that the City has been intentionally relaxed on items such as temporary signage to promote business during the COVID 19 pandemic.

Staff visited multiple commercial corridors between the March 8<sup>th</sup> and the March 22<sup>nd</sup> meeting. The result of the site inspections were there is an abundance of additional site signage across the City including temporary signs and attention getting devices. Although there were businesses currently operating with more window signage than what currently is allowed by code, each individual shopping center or commercial building is quite unique in how they use window signage. A small percentage of the business community had no window signs, a small percentage

were near the top or exceeding what the City’s code allows, and many developments had window signs but not near the maximum allowable amount.

## **PUBLIC HEARING**

A Public Hearing was held on March 22, 2021. At that meeting a few items were brought up by the Commission for staff to research, clarify and bring forward.

### **Summary Table:**

The Commission requested staff bring forward a table that made for an easy/generalized comparison between the current regulations in code and the proposed language brought forward by Staff. Below is a table reflecting a general comparison between the current and proposed language for window signs. Be advised this is not the specific language in code or to be added, but for a general comparison between the two.

Window Sign Criteria	Current Regulation	Proposed Regulation
Number of signs	Unlimited	2 per tenant unless the tenant is the sole occupant of a building located with double frontage then 3 are permitted
Location	Every window on all floors	2 per tenant on the first 2 floors
Size	40% of any window	40% of any window
Permit Required	No	No

*Table 2: Comparison between current and proposed regulation*

### **Interior Signs:**

The Planning Commission discussed the potential regulation of signs inside the building. The question was brought forward to see if there is a certain distance from a window in which the City has the ability to regulate. Although some municipalities do regulate interior signs seen through windows, there does not appear to be a consistent distance or threshold to be applied. Furthermore, the ability to regulate by a certain distance may be difficult in practice. One item to note is that the new technology of window signs allows for light to penetrate the sign but be seen from the exterior. If an applicant were to place a sign on a structure a certain distance back from the window (barring this structure was made from another transparent material like glass), the applicant would most likely not be able to still retain the visibility that makes the adhered to signs so attractive.



**Implementation of the new window sign language:**

There was discussion at the Public Hearing on the implementation of new window sign language if approved. As stated previously in the report, the City has been intentionally relaxed on items such as temporary signage to promote business during the COVID 19 pandemic. This has corresponded to an abundance of additional site signage across the City including temporary signs and attention getting devices. Communication would most likely be needed to inform the City when the suspension of temporary sign regulations that is currently permitted during the pandemic is concluded. One approach to an awareness of updated sign language in code would be to implement a mass communication to businesses of any changes to the window sign regulations in conjunction with the temporary signage communication.

**Input from the City of Chesterfield Police Department:**

Staff was asked to contact the Police Department for any safety guidelines pertaining to how much of a window should not be covered by signage. In response, the police department does not regulate the amount of windows that a particular business has. From a crime prevention standpoint, the more signs on a window, the more difficult it is to see inside the business. The police department provides these tips to businesses within the community to help improve the security of their facility, but they do not see a direct need to regulate it.

**RECOMMENDATION**

The first concern of the Planning and Public Works Committee is that window signs are currently permitted on multiple floors of buildings. The Unified Development Code reads that outline area of window signs, whether temporary or permanent, shall occupy no more than twenty percent (20%) of any window on any other level of the building.

Currently there are very few window signs above the first floor of buildings. Although it may be unlikely in the current environment of Chesterfield, if a building did utilize window signs on a high floor, it could easily conflict with the Purpose delineated in our code, specifically conforming to the character of the community and not overloading the public's capacity to receive information.

A minor adjustment to the code could be made to alleviate the concern. Staff proposes to remove the language referencing other levels, solely permitting window signs on the first floor and second floor of a building. Currently there are not many, if any, businesses that have window signs above the first floor and none known above the second. Although this may have minimal impact on the current conditions, it will prevent a full glass office building from having numerous signs on numerous tenant floors above the first and second level. This alleviates one of the primary concerns of the Planning and Public Works Committee.

The second concern is that there is no maximum on the total number of window signs. An adjustment could be made to alleviate the concern. One solution is to draft similar regulation as

the permitted quantity of wall signs within code. Each tenant will be allowed one window sign on any two windows of a building or particular tenant space, unless the tenant business is the sole occupant of a building located on a corner lot or double frontage, then the business may have one window sign on any three windows. This proposed change allows for consistency within the sign code and guarantees each ground floor or second floor tenant of a building the opportunity to have a window sign, assuming they have a window.

Below is a red-line version of the Unified Development Code incorporating the recommendations above.

Section 405.04.050 F.8.c.

#### Window Signs.

- 1) Subject to the specific regulations set out below, each business occupying a tenant space or being the sole occupant of a freestanding building shall have no more than one (1) window sign on any two (2) windows of a building that are exterior windows of the particular building or tenant space solely on the ground/ first floor or second floor of the building. Window signs may be in addition to other permitted signs.
- 2) For a business being the sole occupant of a building located on a corner lot or a lot with double frontage, said business may have one (1) window sign on any three (3) windows of a building.
- 3) The outline area of said signs, whether temporary or permanent, shall occupy no more than forty percent (40%) of the outline area of any window on the ground/ first or second floor level of the building.
- 4) A sign permit shall not be required for any window sign.

If the Commission felt 2-3 window signs per tenant space on the first and second floor was too restrictive and additional signs may be appropriate, establishing a maximum on the number of signs could be a solution to maintaining the high aesthetic quality of the community.

It is important to note that when considering the regulations of widow signs, items such as hours of operation, open/closed, and other messages that cannot be understood from a position off-site are considered “incidental” and are exempt signs in the City’s Unified Development Code.

It is also important to note that the City of Chesterfield approved Ordinance 3124. This Ordinance acknowledges the economic impact on business due to the COVID 19 pandemic and allows the reasonable temporary suspension for various development criteria including regulation on

temporary signs. The potential updates to code would in no way prohibit or retract from the intent of Ordinance 3124.

Staff also recommends a minor change to the definition of a window sign in Article 10 of the City's Unified Development Code for clarification purposes. The draft red-line change is shown below.

Section 405.10.040 Signage Terms.

#### SIGN, WINDOW

Any sign, including paint, placed ~~inside a window or~~ upon ~~the window~~ a single pane~~s~~ or of glass that is visible from the exterior of the window.

The changes herein are recommended by Staff in order to effectively administer the UDC as originally intended and to implement revised language as directed by the Planning and Public Works Committee. A Public Hearing was held on March 22<sup>nd</sup>, 2021 as an opportunity for Staff to communicate the current regulation on Window Signs, give an opportunity for the public to provide input, and for the Planning Commission to review the current and potentially future regulation and identify whether this language is in line with the purpose of the overall sign requirements for the city. After a vote is taken by the Planning Commission, this project will be presented before the Planning and Public Works Committee for a recommendation to the City Council.

**Staff is requesting that the Planning Commission vote on these amendments in order for them to move forward to the Planning and Public Works Committee.**

Links:

1. [UDC Article 04-05 Sign Requirements](#)
2. [UDC Article 10-04 Signage Terms](#)

Article 04  
**Development Requirements And Design Standards**

**Section 405.04.050 Sign Requirements.**

**[CC 1990 § 31-04-05; Ord. No. 2801 § 3 (Exh. A), 6-16-2014]**

**A. Purpose.**

1. The purpose of the sign regulations provided herein is to encourage excellence in design of signs, fostering economic viability of the community, and provide safe and concise directional information designed to facilitate traffic flow. Signs shall be designed so as to protect motorists, bicyclists, and pedestrians from distractions that may cause accidents or other detrimental impacts.
2. Signs shall not overload the public's capacity to receive information, or cause visual confusion by interfering with pedestrian or vehicular traffic. Signs shall conform to the character of the community, enhance the visual harmony of development, and preserve the public health, convenience, welfare and/or safety within the City of Chesterfield by maintaining the high aesthetic quality of the community.

**B. Scope Of Provisions.**

1. These regulations are supplemented and qualified by the regulations of the particular zoning district in which a sign may be located and by additional general regulations appearing elsewhere in this UDC which are incorporated as part of this Section by reference. This Section contains regulations applicable to all signs in all zoning districts.
2. Regulations for any signs may be made more restrictive in the conditions of the ordinance governing a particular planned district or special procedure. Regulations may also be modified when a sign package is submitted and approved by the City of Chesterfield.
3. On the effective date of this UDC, no sign, except a sign presently so lighted, shall be illuminated by intermittent light sources. This prohibition shall not apply to signs displaying time and temperature, stock market quotes or the manual changeable copy on a sign.
4. When sign illumination is desired, it shall be arranged so as not to cast light directly from any source of illumination on any public right-of-way or on adjoining properties in the

NU Non-Urban, PS Park and Scenic, AG Agricultural or any residential district.

### **C. Permits And Municipal Zoning Approvals (MZAs) For Signs.**

1. Unless excepted by these regulations or the City of Chesterfield Building Code, no sign shall be erected, constructed, posted, altered, enlarged, maintained, or relocated until an MZA has been issued by the Department and a sign permit issued by St. Louis County Department of Public Works. Before any MZA is issued, an application, provided by the Department, shall be filed, together with drawings and specifications as may be necessary to fully advise and acquaint the Department and St. Louis County Department of Public Works with the location, construction, materials, manner of illuminating, and securing or fastening, and the wording or delineation to be carried on the sign. All signs that are to be illuminated by one (1) or more sources of artificial light shall require a separate electrical permit and inspection conducted by St. Louis County Department of Public Works.
2. Structural and safety features and electrical systems shall be in accordance with the requirements of the City of Chesterfield Building Code or any applicable building codes being enforced by the City of Chesterfield. No sign shall be approved for use unless it has been inspected by the Department issuing the permit and is found to be in compliance with all the requirements of this UDC and applicable technical codes. Signs found to be in violation of the requirements of this UDC and/or applicable technical codes and which are determined to be a danger to public health and safety may, after fifteen (15) days of an inspection determining said violation and after notification to the property owner, be dismantled and removed by the City of Chesterfield. The expense for such action shall be charged to the owner of the property on which the sign is erected and shall be filed as a special lien thereon.
3. Planning Commission Approval. The proponent of a sign subject to Planning Commission approval as set out in subsequent sections shall file with the Department, in addition to those document requirements specified in Section 405.04.050(C) of this Article, a written statement addressing the following information:
  - a. The underlying business, directional, or informational purpose of such a sign.
  - b. Why such a sign should exceed the maximum height and/or outline area specification for a particular sign in order to accomplish the underlying purpose as stated in Subsection **(C)(3)(a)** above.

- c. What the proponent of such a sign believes the adverse impact may be upon the underlying business, directional, or informational purpose of such a sign if the proponent is compelled to reduce the height and/or outline area of such a sign to within the maximum height and/or outline area specification for any one (1) sign and the factual basis supporting such belief.
- d. The approximate distance the proposed sign will be from other existing or planned structures visible or planned to be visible within a radius of one thousand (1,000) feet from said sign, identifying such structures with sufficient particularity to enable the Planning Commission to determine whether there is a reasonable likelihood of an adverse public health, convenience, welfare and/or safety impact within the one-thousand-foot radius area while maintaining the high aesthetic quality of said area.
- e. What steps, if any, the proponent has taken to integrate the design with the surrounding environment, including, but not limited to, use of colors and materials, size and character of typeface(s), regularity of overall shape, type of illumination, orientation and situation of such a sign in order to minimize the amount of visual clutter, and to avoid the distraction to pedestrians and motorists beyond that necessary to convey the underlying business, information, or directional purpose of said sign.
- f. If no steps [referred in Subsection **(C)(3)(e)** above] have been taken, provide information as to why such steps should not be required of the applicant.
- g. Any other information, such as length of frontage, special speed limit or topographic considerations, that the proponent deems pertinent to the approval of such a sign request.

**D. Sign Package Submittals. [Ord. No. 3060, 8-19-2019]**

1. The purpose of a sign package is to provide comprehensive, complementary and unified signage throughout a single development or contiguous lots under common ownership. If a sign package exists for a multi-lot development or subdivision, then individual lots within that subdivision or development may not submit their own, separate sign package. In addition, developments of a certain size, quality, or mix of uses may require special signage consideration. Therefore, in order to encourage superior design, quality and character, comprehensive sign packages allow for specialized review of signs and

flexibility from standard signage requirements.

2. When a sign package is requested for a proposed or existing development, the criteria for signs, as provided for in this Article, may no longer be applicable in its entirety or portions thereof. The reason for the requested modification is to provide for flexible sign criteria that promotes superior design and is tailored to a specific development which may vary from general ordinance provisions.
3. Consideration of flexibility in sign criteria is based on a number of review factors, including, but not limited to, the physical impact of the proposed comprehensive sign package, the quality of the proposed comprehensive sign package, and mitigation of unfavorable conditions such as excessive signs, light spillover from signs, height, and other related conditions and potentially negative impacts.
4. When a sign package is requested for a development, the following shall be submitted to the Department:
  - a. A narrative detailing the reasoning for the sign package request and why it will enhance the proposed development above what would be permitted through the City of Chesterfield UDC.
  - b. The maximum number of proposed signs.
  - c. Location, size, height, construction material, and placement of all proposed signs.
  - d. General elevations of all proposed freestanding, monument, wall, and any other sign that requires City of Chesterfield approval.
  - e. Illumination level, color and type. Illumination shall conform to Section 405.04.030, Lighting Standards, of this Article.
  - f. Dimensions, height, square footage of all existing signs or note that none exist for both freestanding and attached signs (submit picture of all existing signage).
  - g. Material specifications for proposed signs, including sign materials and colors.
  - h. Landscaping of any freestanding or monument signs.
5. Electronic Message Centers.

- a. In addition to submittal requirements noted in Subsection (D)(4), any request for an electronic message center shall comply with the following:
- 1) Distance. Electronic message centers that exceed the size requirements eligible for administrative approval per the Unified Development Code (UDC) for permanent freestanding signs shall not be permitted within two thousand (2,000) feet of any property with a land use designation that permits residential uses as determined by the Comprehensive Land Use Plan.
  - 2) Distance. Electronic message centers that exceed the size requirements eligible for administrative approval per the Unified Development Code (UDC) for permanent freestanding signs shall not be permitted within one thousand (1,000) feet from the center point of two intersecting arterial roadways as designated within the City of Chesterfield Street Classification Map.
  - 3) Duration Of Image Display. Each image displayed shall have a minimum duration of ten (10) seconds.
  - 4) Presentation. The image shall be a static display. No portion of the image shall flash, scintillate, fade in or fade out, scroll, twirl, change color, or in any manner imitate movement. No motion imagery, special effect to imitate movement, or presentation of graphics displayed in a progression of frames that give the illusion of motion shall be permitted.
  - 5) Transition. When the image or any portion thereof changes, the change sequence shall only be accomplished by means of instantaneous repixelization.
  - 6) Dimmer Control. The electronic message center shall be equipped with an automatic dimmer control to automatically produce a distinct illumination change from a higher illumination level to a lower level according to ambient light conditions and for the time period between sundown and sunrise.
  - 7) Brightness. The electronic message center shall not exceed a maximum of seven thousand (7,000) nits (candelas per square meter) during daylight hours and a maximum illumination of six hundred (600) nits (candelas per square meter) between sundown and sunrise measured from the sign's face at maximum brightness.



- 8) Fluctuating Or Flashing Illumination. No portion of the electronic message center may fluctuate in light intensity or use intermittent, strobe or moving light or light that changes in intensity in sudden transitory bursts, streams, zooms, twinkles, sparkles or that in any manner creates the illusion of movement.
  - 9) Malfunction And Non-Compliance. In the case of malfunction, digitally-illuminated signs are required to contain a default design to freeze the sign message in one position.
  - 10) Resolution And Pixel Spacing. The electronic message center shall not have a pixel pitch larger than sixteen (16) millimeters (mm).
  - 11) Angle. When the interior angle formed by the faces of a V-shaped sign is less than one hundred eighty degrees ( $180^\circ$ ), both faces of the sign must display the same image.
- b. In considering a sign package that includes an electronic message center, the Planning Commission shall consider the following additional items in their review:
- 1) Proximity of the proposed electronic message center to other similar signs;
  - 2) Proximity and impact on adjacent land uses with particular consideration given to residential properties and uses;
  - 3) Impact of the total amount of signage on the site in conjunction with the use of the electronic message center;
  - 4) Nature and character of the roadway on which the project is located;
  - 5) Nature and character of the proposed use and area within which the project is located;
  - 6) Size of the project and roadway frontage; and
  - 7) Resolution of proposed sign accounting for size of sign, roadway characteristics, and other relevant features.
- c. Any of the standards in Subsection (D)(5)(b) of this Section may be modified by a

separate two-thirds (2/3) vote of the Planning Commission.

- d. Sign packages, including electronic message centers shall only apply to on-site signage. Advertising signs (billboards) are prohibited.
6. Planning Commission Action. The Planning Commission may approve, approve with modifications, or deny the proposed sign package based on its conformance with this Subsection, findings of the submittals furtherance of the purpose in Subsection (A) of this Section, and consistency with the Comprehensive Plan.
7. Appeals. Appeals from any portion of this Subsection, including the Planning Commission's decision on the electronic message center, shall be made to the City Council in accordance with the process and requirements in Section 405.02.190.

**E. Sign Regulations: Area And Height Computations. The following regulations shall govern the computation of sign area and height computations:**

1. Freestanding Sign: Outline Area.
  - a. The outline area of a freestanding sign shall include the area within a continuous perimeter of a plane enclosing the limits of writing, graphic representation, logo, or any figure or similar character, together with the outer extremities of any frame, or other material or color forming an integral part of the display which is used as a background for this sign. The area of a freestanding sign of individually cut out writing, graphic representation, logo, or any figure or similar character which is not enclosed by framing, and which projects from a sign support or main body of a sign, is the sum of the areas of all of the triangles or parallelograms necessary to enclose each writing, graphic representation, logo, or any figure or similar character, including the space between individual letters comprising a word, but not including the space between individual words.
  - b. The outline area of a freestanding sign shall not include the necessary supports for the sign when such supports do not extend above the sign and are not a part of the overall design of a sign. The outline area of a freestanding sign shall also not include the area between separate cabinets or modules of such sign or any pole covers, lighting fixtures, or landscaping, provided that they contain no writing, graphic representation, logo, or any figure or similar character.
2. Freestanding Signs: Height.

- a. Except as may be specifically noted in these regulations, setbacks for all signs shall be governed by the minimum setback yard requirements in each particular zoning district.
  - b. Freestanding business signs shall not exceed the maximum allowed height above the ground elevation. The ground elevation of freestanding signs shall be measured at the elevation of the adjacent street or the average existing finished ground elevation at the base of the sign, whichever is higher.
  - c. The height of all signs on corner lots shall not exceed three (3) feet above the elevation of the adjacent street pavement when located within the sight distance triangle.
3. Attached Sign: Outline Area. The size of attached wall signs shall be measured in the following manner:
- a. The outline area of an attached sign shall include all lettering, graphic representation, logo, design or any figures, together with the background, whether open or enclosed, upon which they are displayed.
  - b. A sign consisting of individually cut out writing is measured as the total area of a rectangle or square enclosing all words. This includes any negative space.

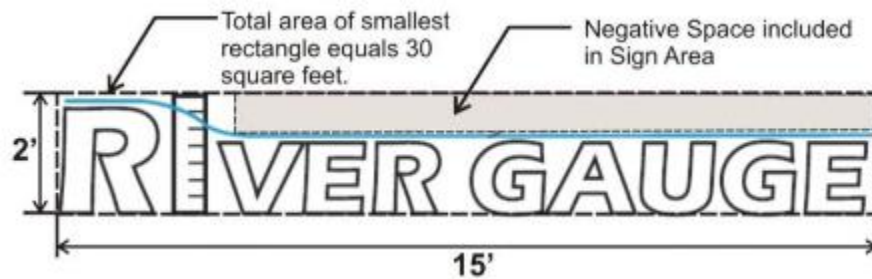

- c. A sign with multiple lines of wording, where the lines are one (1) foot or less apart from each other, shall be measured as the area enclosing the wording on the first line plus the area enclosing the wording on subsequent lines.

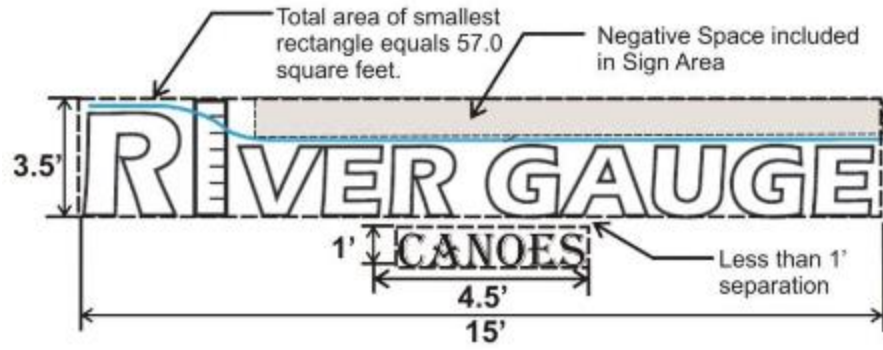

- d. A sign with multiple lines of wording where the lines are greater than one (1) foot apart shall be measured as the total area of the smallest rectangle or square enclosing all words.

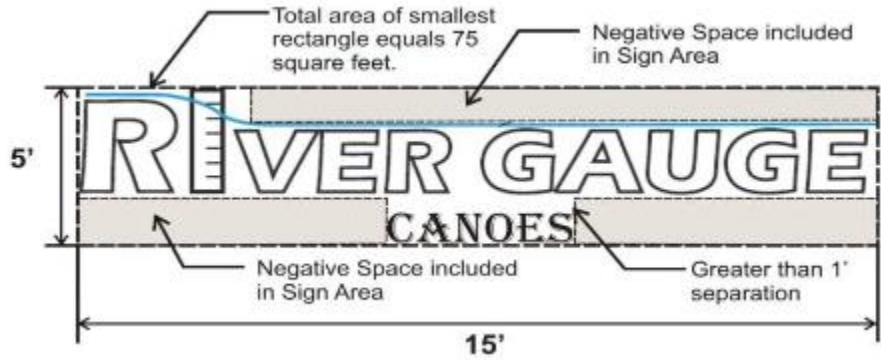

- e. Logos or other graphic representation:
  - 1) When an attached wall sign includes a graphic representation or logo located one (1) foot or less directly above individually cut out writing, the outline area shall be calculated as the sum of the area within the limits of writing plus the area within a rectangle or square enclosing the graphic representation or logo.

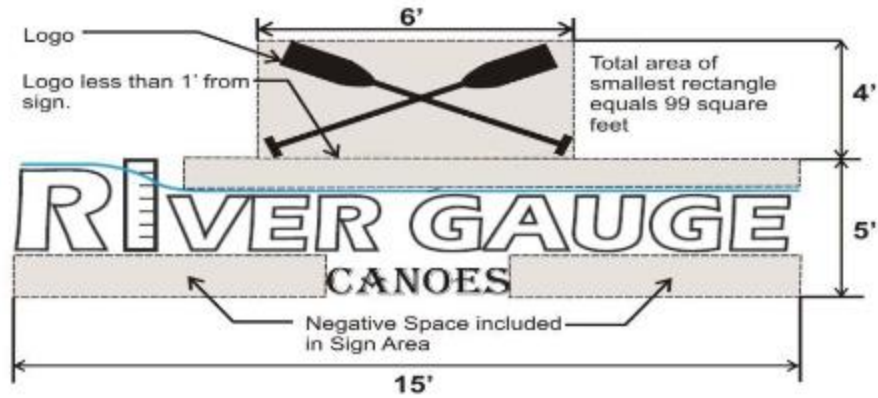

- 2) When an attached wall sign includes a graphic representation or logo located more than one (1) foot directly above individually cut out writing or when a logo or graphic representation is located on either side of individually cut out writing, the outline area shall include the area within a rectangle or square, which completely contains all the sign's letters, logos, figures, designs, graphic representations or symbols.

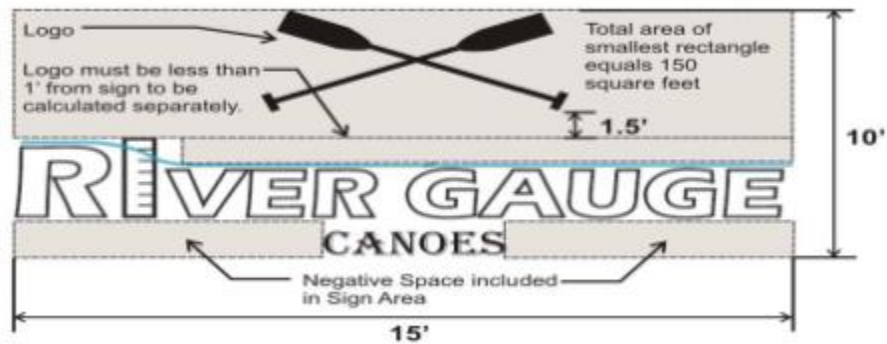

4. Outline Area: Double-Faced Signs. Only one (1) side of a double-faced sign shall be included in the sign area. Double-faced signs shall include those signs where the sign face is parallel or where the interior angle formed by the faces of a V-shaped sign is sixty degrees (60°) or less. If the two (2) faces of a double-faced sign are of unequal area, the area of the sign shall be the area of the larger face.
5. Sign Area On Walls Of Circular Buildings And Other Buildings With Curved Wall Surfaces.
- a. The area constituting a single wall of a circular building shall be designated by the owner on a portion of the wall, but shall be limited to be determined by multiplying three-fourths (3/4) of the diameter of an area of the building by the average height of the exterior walls of the building at the finished ground

elevation of the building.

- b. The area contained on a single wall of a non-circular building with continuous curved wall surfaces shall be designated by the owner on a portion of the wall but shall be limited to an area determined by multiplying three-fourths (3/4) of the average diameter of the building by the average height of the exterior walls of the building at the finished ground elevation of the building.
  - c. The area contained on any single curved wall of a building that is not totally circular or is not composed of a continuous curved wall surface shall be determined by multiplying the shortest distance between the two (2) ends of the arc forming the curved wall surface by the average height of the exterior walls of the curved wall surface at the finished ground elevation of that surface.
  - d. The horizontal length of any single wall of a building that is characterized by the multiple curved wall surfaces or other irregular wall surfaces shall be measured as a straight line extending between both edges of the wall.
6. Outline Area: Exceptions. The total outline area for any freestanding signs shall be exclusive of any decorative trim. Said trim shall not exceed thirty percent (30%) of the outline area as determined in accordance with Section 405.04.050(F)(1) of this Article.

**F. Sign Regulations: Permanent Signs. The following provisions shall govern the erection of all permanent signs, together with their appurtenant and auxiliary devices, with respect to size, number, height, location and construction.**

1. General Provisions.

- a. Permitted business, information, and directional signs may either be a flat sign permanently affixed to the face of a building, awning or canopy or be freestanding. Business information and directional signs affixed to buildings shall not project above the eave line of the roof, except as an integral roof sign.
- b. Permitted information or directional signs may be flat signs permanently affixed to a boundary wall or fence. However, other than a horizontal projection of not more than six (6) inches, such signs shall not project beyond the surface of the boundary wall or fence.

- c. All freestanding signs shall be located so as not to impair the visibility of any official highway sign or marker, and no business sign shall be so placed as to unnecessarily obstruct the visibility of any other business sign.

2. Business And Identification Signs: Freestanding.

a. General.

- 1) Subject to other provisions of this Section, each developed lot may have no more than one (1) freestanding business sign facing each roadway on which the lot has frontage, regardless of the number of buildings upon the lot. Furthermore, each building, regardless of the number of lots upon which it may be located, shall have no more than one (1) freestanding business sign facing each roadway on which its lot or lots has frontage. For the purpose of these regulations, an aggregation of two (2) or more structures connected by a wall, firewall, facade or other structural element, except for a sidewalk, shall constitute a single building.
- 2) The height of all business and identification signs shall not exceed six (6) feet when located within the minimum front yard setback of a particular zoning district.

b. Specific Regulations And Exceptions.

- 1) A freestanding business sign shall not exceed six (6) feet in height above the average existing finished grade at the base of the sign, or the elevation of the adjacent street, whichever is higher. The total outline area per face shall not exceed fifty (50) square feet or twenty-five one hundredths (0.25) square foot of signage per linear foot of street frontage up to one hundred (100) feet of street frontage and one-tenth (0.1) square foot of signage per linear foot of street frontage thereafter, whichever is less. (See exceptions below.)
- 2) Said sign face shall be attached to a proportionate enclosed base, integrated planter or structural frame, the width of which shall be a minimum of one-half (1/2) the width of the widest part of the sign face. The bottom of the sign face shall not exceed a height of three (3) feet above the average existing finished grade at the base of the sign, or elevation of the adjacent street, whichever is higher. An enclosed sign base or integrated planter shall not be required if the sign face is within one (1) foot of the average finish grade at

the base of the sign.

a. Exceptions:

1. For each additional four-foot setback from the minimum yard requirement, one (1) additional foot may be added to the sign height to a maximum of ten (10) feet above the average existing finished grade at the base of the sign or elevation of the adjacent street, whichever is higher. However, at no time shall the bottom of the sign face exceed a height of three (3) feet above the average existing finished grade at the base of the sign or the elevation of the adjacent street, whichever is higher; or
  2. The maximum outline area and/or height of any freestanding business sign may be increased to a maximum of one hundred (100) square feet in outline area and/or twenty (20) feet in height above the average existing finished grade elevation at the base of the sign or elevation of the adjacent street, whichever is higher, with no height restriction for the bottom of the sign face subject to Planning Commission approval as outlined in Section 405.04.050(C) of this Article.
- 3) An individual lot having a minimum of eight hundred fifty (850) feet of frontage on any roadway, and a minimum size lot of twenty (20) acres or more, shall be allowed two (2) freestanding business signs on each roadway frontage exceeding seven hundred fifty (750) feet of frontage. However, a minimum of four hundred (400) feet shall separate the two (2) permitted signs. In lieu of the two (2) permitted freestanding signs, one (1) freestanding business sign may be permitted, the maximum outline area of which may be increased to one hundred fifty (150) square feet, subject to Planning Commission approval as outlined in Section 405.04.050(C)(3), Planning Commission approval, of this Article.
- 4) A single commercial or industrial development or subdivision which is in excess of twenty (20) acres in size shall be permitted a project identification sign at each main entrance to the subdivision or development identifying the name of the project and/or containing a directory of tenants. The sign may include the name and/or logo of the development or subdivision. Such sign



may be located on any platted lot or common ground of a development or subdivision or any unplatted portion of the development or subdivision identified as part of a particular development on an approved preliminary plat, site development concept plan, site development section plan, or site development plan.

- 5) A project identification sign shall not exceed six (6) feet in height above the average existing finished grade at the base of the sign or elevation of the adjacent street, whichever is higher, with the total outline area per face not to exceed fifty (50) square feet or twenty-five one hundredths (0.25) square foot of signage per linear foot of street frontage up to one hundred (100) feet of street frontage and one tenth (0.1) square foot of signage per linear foot of street frontage thereafter, whichever is less.

a. Exceptions:

- 1) For each additional four-foot setback from the minimum yard requirement, one (1) additional foot may be added to the sign height of a project identification sign to a maximum of ten (10) feet above the average existing finished grade at the base of the sign or elevation of the adjacent street, whichever is higher. However, at no time shall the bottom of the sign face exceed a height of three (3) feet above the average existing finished grade at the base of the sign or the elevation of the adjacent street, whichever is higher; or
  - 2) The minimum outline area and/or height of any project identification sign may be increased to a maximum of one hundred (100) square feet in outline area and/or twenty (20) feet in height above the average existing finished grade elevation at the base of the sign or elevation of the adjacent street, whichever is higher, with no height restriction for the bottom of the sign face subject to Planning Commission approval as outlined in Section 405.04.050(C)(3), Planning Commission Approval, of this Article.
- 6) Commercial, industrial or mixed use subdivisions of ten (10) lots/units or more that are less than twenty (20) acres shall be permitted a subdivision identification sign at each main entrance to the subdivision and may include the name, logo and/or the directory of tenants of the subdivisions. Such sign shall not exceed fifty (50) square feet in outline area per face, nor extend

more than six (6) feet above the average existing finished grade at the base of the sign or elevation of the adjacent street, whichever is higher. Commercial, industrial or mixed use subdivision identification signs shall be located within an easement on any platted lot or on common ground of subdivision. Such sign may also be located on any unplatted portion of the subdivision identified as part of a particular development on an approved preliminary subdivision plat, site development concept plan, site development section plan, or site development plan. No subdivision identification sign shall be permitted for a development permitted a project identification sign.

7) Developments over twenty (20) acres located adjacent to major arterials may increase the height and the size of the project identification sign by decreasing the number of permitted project identification signs with approval of the Department. The maximum size of one (1) sign utilizing this Section shall be thirty (30) feet in height and one hundred fifty (150) square feet of outline area per face. Total square footage is not to exceed the original allowed by the Planning Commission.

8) Landscaping. All permanent freestanding signs shall have landscaping, which may include, but not be limited to, shrubs, annuals, and other materials, adjacent to the sign base or structural supports. If the outline area and/or a height increase for any permanent freestanding sign is requested, the required landscaping for such a sign will be subject to Planning Commission approval.

c. A service station shall be permitted one (1) separate price sign attached to the same structure of any one (1) permitted freestanding business sign on the lot or lots on which the use may be located. The outline area of a separate price sign shall not exceed twenty (20) square feet per face.

d. A movie theater shall be permitted one (1) additional freestanding business sign, with manual changeable copy only, facing each roadway on which the lot containing the movie theater has frontage. All size requirements as provided for in Section 405.04.050(F) of this Article shall apply.

### 3. Business Signs: Attached To Wall.

a. General Provisions.

- 1) Subject to the specific regulations set out below, each business occupying a tenant space or being the sole occupant of a freestanding building shall have no more than one (1) attached business sign on any two (2) walls of a building that are exterior walls of the particular building or tenant space. In addition to identifying a particular business, such signs may be used for the name and logo of the building or development project.
- 2) The outline area of each sign shall not exceed five percent (5%) of the wall area of the business on which said sign is attached. No business sign shall exceed three hundred (300) square feet in outline area.
- 3) Countable wall area shall include the entire surface of a wall, such as gable and similar areas, and the vertical face of a mansard roof, whether real or artificial, which extends above the wall of the business on which the sign is attached. However, the countable area of mansard roofs shall be limited to the area not greater than six (6) feet above the eave line of the roof times the length of associated wall.

Example: Where "Z" equals the maximum square footage of a wall sign. The height of a building "Y" is multiplied the width of a building "X" to provide the total square footage of the facade. This value is then multiplied by five hundredths (0.05) or five percent (5%) to provide "Z" the maximum signage square footage. See Illustration A:



b. Specific Regulations And Exceptions.

- 1) For a business being the sole occupant of a building located on a corner lot or a lot with double frontage, said business may have one (1) attached business sign on any three (3) walls of a building that are exterior walls.

- 2) Where a lot or parcel of land is developed with more than one (1) building, interior buildings shall be permitted the same type and number of wall signs on the interior buildings as are allowed on peripheral buildings. The mounting requirements of the permitted signs shall be the same as any attached business sign.
- 3) In buildings containing single or multiple tenants where public access to individual tenant space(s) is gained via interior entrances, said building shall be allowed no more than one (1) attached business sign on any two (2) walls having roadway frontage. Said attached business signs shall be the same, each identifying either the building or major tenant.
- 4) Individual letters (exclusive of words), a symbol or graphic logo pertaining to a business on premises, may be painted or otherwise permanently affixed to the surface of an awning or canopy. The outline area of the message shall not exceed fifteen percent (15%) of the horizontal projection in elevation of the exterior surface of the awning or canopy. Said message outline area, when utilized as a design accent only as described above, shall not be counted toward the allowable outline area for a business sign.
- 5) Where a multitenant building contains both public access to individual tenant space(s) via interior entrances and an additional exterior access point(s) that services only one (1) tenant, signage may be permitted above said exterior access point of the tenant. This signage is in addition to the exterior signage permitted in Subsection (F)(3)(b)(3) above. The outline area of each sign shall not exceed five percent (5%) of the wall area of the business on which said sign is attached. No business sign shall exceed three hundred (300) square feet in outline area.

#### 4. Directional Signs.

- a. Directional signs shall not exceed ten (10) square feet in outline area per facing. Freestanding directional signs shall not extend more than six (6) feet above the elevation of the adjacent street or elevation of the average existing finished grade at the base of the sign, whichever is higher.
- b. The height of all directional signs shall not exceed three (3) feet when located within the minimum front yard setback of each particular zoning district.

- c. No directional sign shall be located on or over a public right-of-way without approval of the City of Chesterfield, and/or St. Louis County Department of Highways and Traffic, and/or the Missouri Department of Highway and Transportation as applicable.

5. Advertising Signs (Billboards).

- a. Advertising signs [Subsection (F)(5) refers to billboards only] are permitted in the Planned Commercial District, Planned Industrial District, and MXD Mixed Use Development District if permitted in the conditions of the ordinance governing the particular planned district.
- b. Advertising signs shall not exceed eight hundred (800) square feet in outline area, nor extend more than thirty-five (35) feet above the elevation of the adjacent street. Subject to more restrictive regulations of the zoning district in which it is located, an advertising sign shall not be located closer than one hundred (100) feet to any other advertising sign or building, nor within fifty (50) feet of any PS Park and Scenic or any residentially zoned property or any property line of any NU Non-Urban zoned property, nor within ten (10) feet of any side or rear property line. Not more than one (1) advertising sign shall be permitted on one (1) structure, except that where a structure is located perpendicular to the street right-of-way, two (2) sign facings shall be permitted in each direction.
- c. No outdoor advertising sign shall be located within fifty (50) feet of any roadway right-of-way line, except that where existing buildings on immediately adjacent tracts (on both sides) are located closer to the roadway right-of-way than fifty (50) feet, an advertising sign may be placed within the average setback of the existing buildings on each side of the advertising sign. Where a building on an adjacent tract exists on one (1) side only, located closer to the roadway right-of-way than fifty (50) feet, an advertising sign may be placed within the average setback of the existing building and the fifty-foot setback required by these regulations.
- d. Notwithstanding the regulations as set out above, all advertising signs (billboards) must be in conformance with Sections 226.500 through 226.600 RSMo., as amended.
- e. Separation From Other Zoning Districts. No advertising sign shall be located within one thousand (1,000) feet of any NU Non-Urban District, AG Agricultural,

residential districts, or PS Park and Scenic District zoned tract, or any tract subject to the landmark and preservation area special procedure.

- f. Separation From Other Advertising Signs. No advertising sign shall be erected within five (5) miles of any existing sign on the same side of the highway. No sign shall be located in such a manner as to obstruct or otherwise physically interfere with the effectiveness of any official traffic sign, signal, or device, or obstruct or physically interfere with motor vehicle operators' view of approaching, merging, or intersecting traffic. The separation requirements between advertising signs outlined in this Subsection shall be measured perpendicular to the center line off the subject highway. The separation distance shall apply only to advertising sign structures located on the same side of the subject highway.
- g. Lighting. No revolving or rotating beam or beacon of light that simulates any emergency light or device shall be permitted as part of any advertising sign. No flashing, intermittent, or moving light or lights shall be allowed. External lighting, such as floodlights, thin line and gooseneck reflectors may be permitted in the conditions of the ordinance governing a particular planned or mixed use district, provided that the light source is directed upon the face of the sign and is effectively shielded so as to prevent beams or rays of light from being directed into any portion of the public right-of-way. Lights shall not be of such intensity so as to cause glare, impair the vision of the driver of a motor vehicle, or otherwise interfere with a driver's operation of a motor vehicle. No sign shall be so illuminated that it interferes with the effectiveness of, or obscures, an official traffic sign, device, or signal, nor shall any sign illumination cast light on adjacent properties.
- h. In accordance with the authority granted to the City pursuant to H.B. 831, 89th General Assembly (1997), the following regulations shall apply to all billboards and outdoor advertising structures, within the meaning of H.B. 831 and Sections 226.500 to 226.600, RSMo., which are placed or proposed to be placed at any location within the view of any federal, State, interstate, primary or other highway within the City:
  - 1) No outdoor advertising structure or billboard shall be erected or maintained which exceeds fifteen (15) feet in height above ground level.
  - 2) No outdoor advertising structure or billboard shall be erected or maintained within the view of any federal, State, interstate or primary highway at a

distance of less than five (5) miles from any other outdoor advertising structure or billboard within the City which is visible to persons traveling in the same direction on such highway.

- 3) No outdoor advertising structure or billboard, other than on-premises signage specifically regulated pursuant to other provisions of the UDC of the City of Chesterfield, shall be lighted or artificially illuminated after dark in any manner visible from any location outside the right-of-way of the highway from which the outdoor advertising structure or billboard is visible.

6. Informational Signs.

- a. Informational signs shall not exceed sixteen (16) square feet in outline area per facing. Freestanding informational signs shall not extend more than six (6) feet above the elevation of the adjacent street or elevation of the average existing finished grade at the base of the sign, whichever is higher.
- b. No informational sign shall be located on or over a public right-of-way without approval of the City of Chesterfield, and/or St. Louis County Department of Highways and Traffic, and/or the Missouri Department of Highway and Transportation as applicable.
- c. The height of all informational signs shall not exceed six (6) feet when located within the minimum front yard setback of each particular zoning district.
- d. Outdoor public artwork or public art displays are permitted one (1) information sign. Signage shall not exceed three (3) feet in height, from grade to top of sign, and the sign face shall not exceed ten (10) inches by ten (10) inches or five (5) inches by twenty (20) inches in outline area. Requests for modification to the size limitation shall be reviewed by the City of Chesterfield City Council. Said modification shall require a two-thirds-vote of the City Council.

7. Residential Subdivision Identification Signs. Residential subdivisions of ten (10) lots/units or more shall be permitted a subdivision identification sign at each main entrance to the subdivision and may include the name or logo or both of the subdivision. Such sign shall not exceed fifty (50) square feet in outline area per face, nor extend more than six (6) feet above the average existing finished grade at the base of the sign or elevation of the adjacent street, whichever is higher. Residential subdivision identification signs shall be located within an easement on any platted lot or on common ground of a subdivision.

Such sign may also be located on any unplatted portion of the subdivision identified as part of a particular development on an approved preliminary subdivision plat or site development concept plan, site development section plan, or site development plan.

8. Supplementary Regulations.

a. Church Or House Of Worship.

- 1) A church or house of worship located in any district shall be permitted one (1) freestanding identification sign. However, a church or house of worship which has a minimum frontage of four hundred (400) feet on each of two (2) or more roadways shall be permitted one (1) freestanding identification sign on each of two (2) such roadways. Said identification sign height shall be in accordance with Section 405.04.050(F), Sign Regulations: Permanent Signs, of this Article. The copy portion of such sign shall not exceed fifty (50) square feet in area, exclusive of one (1) separate religious symbol without lettering which may have an additional outline area not exceeding twenty (20) square feet.
- 2) A church or house of worship shall have no more than one (1) attached identification sign with the size requirements in accordance with Section 405.04.050(F), Sign Regulations: Permanent Signs, of this Article.
- 3) A church or house of worship within the City of Chesterfield is permitted to have two (2) off-site directional signs, not to exceed six (6) square feet. The sign message shall be limited to church name and location/direction. A permit is required for all church signs. If the sign is not maintained, the City will require its repair or removal.

- b. Hospitals, public park and recreation facilities, schools, libraries, auditoriums, and similar institutions for public assembly having a minimum frontage of two hundred fifty (250) feet on a roadway shall be permitted one (1) freestanding identification sign not to exceed fifty (50) square feet in outline area per face on each roadway meeting the above minimum frontage requirements. Said identification sign height shall be in accordance with Section 405.04.050(F), Sign Regulations: Permanent Signs, of this Article. Each hospital, public park and recreation facility, school, library, auditorium, or other similar institutional use shall have no more than one (1) attached identification sign with the size requirements in accordance with Section 405.04.050(F), Sign Regulations:



Permanent Signs, of this Article.

- ~~c. Window signs may be placed on any window in addition to other permitted signs. However, the outline area of said signs, whether temporary or permanent, shall occupy no more than forty percent (40%) of the outline area of any window on the ground or first floor level of the building and no more than twenty percent (20%) of any window on any other level of the building. A sign permit shall not be required for any window sign.~~
- d. Signs placed on vending machines, express mailboxes, or service station pumps advertising products sold or services offered from the particular machine, mailbox, or pump are permitted. However, no vertical or horizontal projection greater than six (6) inches from the surface of the machine, mailbox, or pump is permitted. Any other sign placed on the machine shall be considered as an advertising, business, directional, or information sign, subject to the regulations of the zoning district in which such sign is located.
- e. A restaurant with a drive-up or drive-through food pickup facility may have either one (1) freestanding or one (1) wall menu sign not to exceed thirty-two (32) square feet in area associated with the order station. No freestanding menu sign shall exceed eight (8) feet in height or width or be illuminated in any manner other than from an internal source.
- f. A financial institution with an outdoor automatic teller or similar facility may have either one (1) freestanding or one (1) wall sign not to exceed sixteen (16) square feet in outline area associated with the facility. No freestanding sign for such a facility shall exceed eight (8) feet in height or width or be illuminated in any manner other than from an internal source.
- g. A service station with a canopy may have no more than one (1) sign which may include the name and logo of the business and one (1) sign which may include the words "self-service" and "full service" attached on each of any two (2) sides of the vertical face of the canopy, excluding canopy supports. The outline area of each sign shall not exceed ten (10) square feet in outline area. Each sign shall be a flat sign permanently affixed to the vertical face of the canopy and shall not project above or below the vertical face of the canopy more than one (1) foot. No projection shall be permitted from any other side of the vertical face of the canopy. Such signs shall only be illuminated by internal and non-intermittent light sources. For service stations located on corner lots, such signs may be

located on each of any three (3) sides of the vertical face of the canopy, excluding canopy supports.

- h. In addition to other freestanding or attached wall signs in this Section, an individual lot or project may have a sign displaying time and temperature, and/or stock market activity not to exceed twenty-four (24) square feet in outline area per face. Such sign may be attached to the same structure of any permitted freestanding business sign, or may be a flat sign permanently affixed to the face of a building. When affixed to a building, such sign shall not project above the eave line of the roof.

**G. Sign Regulations: Temporary Signs And Attention-Getting Devices. The provisions of this Section shall govern the erection of all temporary signs and attention-getting devices, together with their appurtenances, with respect to size, height, location, and construction.**

1. General.

- a. A sign not permanently affixed to a vehicle or trailer which is parked or located such that the primary purpose is to display such sign is prohibited. This prohibition shall not apply to signs or lettering on buses, trucks, or other vehicles while in use in the normal course of business.
- b. For the purpose of these regulations, a temporary sign shall be considered any sign permitted for a duration not to exceed one (1) year.

2. Advertising Or Informational Signs (On-Premises). The following provisions shall govern the erection of all temporary advertising/informational signs and appurtenances with respect to size, height, location and construction.

- a. Banners. Commercial banners, except those used for real estate leasing, affixed to a fence or wall or similar structure are allowed in conjunction with a special promotion or grand opening with a temporary sign authorization. The use of a banner in conjunction with a grand opening shall be limited to a fifteen-day period. Banners used for special promotions shall be limited to thirty (30) days per calendar year for each business. Said banner shall not exceed fifty (50) square feet in outline area.
- b. Flags. One (1) commercial flag incorporating a business name and/or logo may

be flown in conjunction with a flag display in all commercial, industrial and mixed use development districts. One (1) commercial flag incorporating a business name and/or logo used in conjunction with a flag display may be flown in the NU Non-Urban District, AG Agricultural and all residential districts operating under a conditional use permit. A minimum of three (3) flags, including a local, State or national flag in addition to one (1) permitted commercial flag shall constitute a flag display. All flag lengths, excepting the national flag, shall not exceed ten (10) feet, with a pole height not to exceed forty (40) feet. An MZA and building permit is required prior to erecting any flagpole.

- c. Garage Sale. Garage sale signs may be erected on premises in the NU Non-Urban District, AG Agricultural and all residential districts only. A temporary sign authorization is not required for garage sale signs.
- d. Public Information Signs. Freestanding public information signs are allowed in any zoning district with a temporary sign authorization. Said signs shall not exceed thirty-two (32) square feet nor extend more than ten (10) feet above the elevation of the street adjacent, or the average existing finished grade at the base of the sign, whichever is higher. The height of any public information sign shall not exceed six (6) feet when located in the minimum front yard setback of a particular zoning district.
- e. Sandwich Boards. Sandwich boards, not to exceed eight (8) square feet per face, may be used to convey commercial messages in all commercial districts, Industrial districts and MXD Mixed Use Development Districts. A sandwich board shall be considered as an incidental sign and therefore should not be visible from off site. At no time shall a sandwich board block a public walkway. An MZA is not required for a sandwich board.
- f. Window Signs. ~~Window signs may be placed on any window in addition to other permitted signs. However, the outline area of the signs, whether temporary or permanent, shall not exceed forty percent (40%) of the window in which it is placed on the first floor and shall not exceed twenty percent (20%) of any window for which it is placed on any other level of the building. The method for calculating area shall be as provided for in Section 405.04.050(F)(3) of this Article. An MZA shall not be required for window signs.~~

- 1) Window Signs shall not occupy more than twenty percent (20%) of any single window area. The window area may include multiple panes of glass

separated only by supporting framing materials but not separated by architectural elements. Further, glass located within a door, whether or not it is used as an entrance/exit, is not an eligible location for a window sign.

2) Window Signs are solely permitted on the first and second floor of a building.

3) A sign permit shall not be required for any window sign.

g. Living or human signs associated with a commercial or retail business or activity are permitted on the premises of the business for which the advertising is for. The maximum size of a sign that may be held by an individual is three (3) square feet. These signs do not require an MZA and are not permitted off-site or within the right-of-way.

3. Advertising Or Informational Signs (Off-Premises).

a. General. Temporary off-premises advertising/informational signs, such as portable signs attached to vehicles, are prohibited by the provisions of these regulations.

b. Specific Regulations And Exemptions. Banners and freestanding public information signs which convey public, not-for-profit, or civic information are permitted with a temporary sign authorization. Street banners shall not exceed thirty (30) inches by eighty-four (84) inches per face. Freestanding public information signs shall not exceed thirty-two (32) square feet in outline area or ten (10) feet in height above the elevation of the adjacent street, or average existing finished grade at the base of the sign, whichever is higher. Signs that are accessory to signage for a civic, non-commercial event shall be subject to Department approval.

4. Political Signs: political campaign signs announcing the candidates seeking public political office and other pertinent data. The maximum area for any one (1) sign shall be eight (8) square feet, with a total area of sixteen (16) square feet permitted for each lot or unit. These signs shall be erected only on private property and shall be removed within seven (7) days after the election for which they were made.

5. Temporary Off-Premises Directional Signs.

a. Temporary off-premises directional sign(s) shall be allowed for businesses where recent changes in traffic patterns adversely affect access to said businesses, as

determined by the Department. Said temporary direction sign(s) may be erected for a period not to exceed six (6) months following completion of construction.

- b. Said temporary directional sign(s) shall not exceed ten (10) square feet in outline area per face, nor extend more than six (6) feet above the elevation of the adjacent street or elevation of the average existing finished grade at the base of the sign, whichever is higher.
- c. The height of a temporary directional sign shall not exceed three (3) feet when located within the minimum front yard setback of each particular zoning district.
- d. No temporary directional sign shall be located on or over a public right-of-way without approval of the City of Chesterfield, and/or St. Louis County Department of Highways and Traffic, and/or the Missouri Department of Highway and Transportation, as applicable.

6. Temporary Signs: Development Related.

- a. General. Only one (1) construction, future use of site, or subdivision promotion sign may be erected per roadway frontage at any one time after first obtaining the required zoning approval and sign permit. At no time shall guy wires or auxiliary support posts be used to anchor a temporary development related sign.
- b. Banners, Subdivision Identification. Subdivision identification banners are allowed in any zoning district with a temporary sign authorization. Said banners shall not exceed thirty (30) inches by eighty-four (84) inches in sign area and shall be erected, internal to a subdivision, for a period not to exceed one (1) year.
- c. Flags, Subdivision Promotion. Within developing subdivisions, subdivision promotion flags are allowed without securing a temporary sign authorization; however, an MZA and building permit are required prior to erecting a flagpole. Said flags shall not be flown on poles exceeding sixteen (16) feet in height with a flag length not to exceed two and one-half (2 1/2) feet.
- d. Temporary Construction Signs.
  - 1) Construction signs which identify the architects, engineers, contractors or other individuals or firms involved with construction on a site may be erected during the construction period. Each construction site may have no more than one (1) such sign facing each roadway on which the site has frontage.

No construction sign shall exceed thirty-two (32) feet in outline area, nor exceed ten (10) feet in height above the average existing finished grade.

- 2) The signs shall be confined to the site of the construction and shall be removed no later than fourteen (14) days after completion of all construction on the site or after ninety (90) days of suspension of work. The message on a construction sign shall not include any advertisement of a product but may include information announcing the character of the business enterprise or the purpose for which the business is intended.
  - 3) The maximum outline area of a temporary construction sign may be increased to sixty-four (64) square feet subject to Planning Commission approval as outlined in Section 405.04.050(C)(3) of this Article.
- e. Temporary Signs Announcing Future Use Of Site.
- 1) Signs announcing the future use of a site, by a use permitted by the regulations of the particular zoning district in which the lot or development is located or by an approved special procedure permit, may be erected immediately following the approval of said use but not more than six (6) months prior to construction or development of the site. If after six (6) months construction has not commenced, the sign(s) must be removed. Signs announcing future use of a site shall be erected only on the lot or development in question and shall be removed within fourteen (14) days after the completion of construction of a building on the site in the case of a previously undeveloped site, or the occupancy of an existing building, or the beginning of the intended use of the site where no building is to be constructed.
  - 2) Each site may have no more than one (1) such sign facing each roadway on which the site has frontage. No such sign shall exceed thirty-two (32) square feet in outline area per facing, nor exceed ten (10) feet in height above the average existing finished grade elevation of the sign or elevation of the adjacent street, whichever is higher.
  - 3) The maximum outline area of temporary signs announcing future use of a site may be increased to sixty-four (64) square feet, subject to Planning Commission approval, as in Section 405.04.050(C)(3) of this Article.

f. Subdivision Direction Signs.

- 1) For the purpose of these regulations, a subdivision direction sign is a sign placed at some location outside the limits of a residential subdivision intended to inform and direct the general public to an approved or pending development. Subdivision direction signs may not be erected until a site plan or preliminary plat has been approved for the subject development. The message upon the sign shall be limited to the name of the subdivision, the name of the developer, insignia, price range, a directional arrow, and written directions.
- 2) Signs may have one (1) face, a face on each side of the sign board, or be V-shaped [not to exceed an interior angle of sixty degrees (60°)] and contain two (2) faces.
- 3) Subdivision direction signs may be erected on properties at any of the corners of intersecting streets, highways or roads, subject to the following criteria. See Illustration B.

a. Location:

- 1) Within the area bounded by the street right-of-way lines, a line connecting two (2) points from the street right-of-way lines one hundred thirty (130) feet from the point of intersection of the street right-of-way lines, but not including the area within the sight distance triangle; or
- 2) Subdivision direction signs may be erected beyond a point located not closer than one hundred thirty (130) feet, but not farther than two hundred thirty (230) feet from the point of intersection of the street right-of-way lines, as measured along the right-of-way line.
- 3) In the case of non-symmetrical intersections, the limits established for sign placement shall be measured from the prolongation of the right-of-way lines on the opposite side of the street.
- 4) No subdivision direction sign shall be erected within the sight distance triangle or otherwise be placed to obstruct vehicular sight distance.

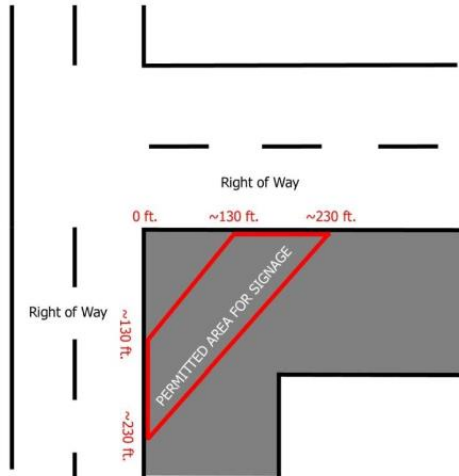

- b. Subdivision direction signs shall be located no closer to the street right-of-way line than permitted under the requirements for structure setbacks of the applicable zoning district.
- c. Guy wires shall not be utilized to anchor the sign.
- d. Subdivision direction signs shall not be located closer than twenty (20) feet to any other sign.
- e. Not more than four (4) subdivision direction signs, each authorizing the placement of a single subdivision direction sign at a location, will be authorized for each development at any given time. Each development is allowed not more than four (4) sign locations concurrently. For the purposes of this Section, multiple plats or phases of contiguous development shall be considered a single development without regard to ownership.
- f. All subdivision direction signs shall be removed within one (1) year of the date the authorization was issued for said sign.
- g. A limit of one (1) sign per development shall be allowed at an intersection.
- h. A residential subdivision located outside the City limits of the City of Chesterfield shall be permitted one (1) subdivision directional sign to



be located within the City of Chesterfield.

- i. A limit of four (4) subdivision direction signs shall be allowed per intersection. Only one (1) of the four (4) subdivision direction signs per intersection shall be permitted for a residential development located outside the City limits of the City of Chesterfield.
- j. Each sign face shall have a decorative border of a minimum width of one and one-half (1 1/2) inches.
- k. No single sign shall exceed thirty-two (32) square feet or be less than sixteen (16) square feet in outline area. The total permitted sign area allocated for an individual development shall not exceed ninety-six (96) square feet.

4) An MZA shall be obtained from the Department for the placement of all subdivision direction signs. Applicant must provide a written consent authorizing the removal of said sign upon permit expiration. Any existing subdivision directional sign erected prior to the establishment of this UDC shall be permitted until expiration of the municipal zoning approval.

5) Sign Maintenance. The permittee of any approved subdivision direction sign is required to maintain such signage in a safe and satisfactory manner. A sign is considered to be unsafe and in unsatisfactory condition if the sign contains peeling paint, and/or the sign surface or support structures are rotted, warped, damaged, faded, sun-baked or deteriorated. If the Department determines repair is needed and the owner fails to repair said sign within thirty (30) days of receiving notification of the disrepair, the City will remove such signs at the permittee's expense.

g. Subdivision Promotion Signs.

1) For the purpose of these regulations, a "subdivision promotion sign" is a sign which may be erected within a subdivision in progress and which is intended to inform the general public about the project. Subdivision promotion signs may not be erected until a site plan or preliminary plat has been approved for the subject development. The message upon the sign shall be relevant to the subdivision, including the name of the subdivision, the name of the developer, insignia, price range, and related information.

- 2) Subdivision promotion signs shall not exceed thirty-two (32) square feet. The maximum outline area of a subdivision promotion sign may be increased to sixty-four (64) square feet subject to approval by the Planning Commission as outlined in Section 405.04.050(C)(3) of this Article.
- 3) Subdivision promotion signs shall not exceed ten (10) feet in height above the average existing finished grade at the base of the sign or above the elevation of the adjacent street.
- 4) Location.
  - a. Subdivision promotion sign(s) may be erected at each main entrance to a subdivision or at the entry to each individual plat of a subdivision.
  - b. No subdivision promotion sign shall be erected within the sight distance triangle or otherwise be placed to obstruct vehicular sight distance.
  - c. No subdivision promotion sign shall be located within a street right-of-way, access easement or designated emergency accessway.
- 5) Guy wires shall not be utilized to anchor the sign.
- 6) An MZA shall be obtained from the Department for the placement of all subdivision promotion signs. The applicant must provide a written consent authorizing the removal of said sign upon permit expiration.
- 7) Sign maintenance. The permittee of any approved subdivision promotion sign is required to maintain such signage in a safe and satisfactory manner. A sign is considered to be unsafe and in unsatisfactory condition if the sign contains peeling paint, and/or the sign surface or support structures are rotted, warped, damaged, faded, sun-baked or deteriorated. If the City of Chesterfield determines repair is needed and the owner fails to repair said sign within thirty (30) days of receiving notification of the disrepair, the City will remove such signs at the permittee's expense.
- h. Display House Signs.
  - 1) For the purpose of these regulations a "display house sign" is a sign placed on a subdivision lot where a display house has been properly permitted by

the City. The display house sign is intended to provide information to the general public related to the display home. In those instances where lots have not yet been permitted, display house signs shall only be permitted in those locations where construction has been authorized by an approved display house plat.

- 2) A single display house promotion sign may be erected on each lot on which a display house has been erected.
  - i. Attention-Getting Devices (On-Premises). Attention-getting devices, which shall include, but are not limited to, inflatables, beacons, festoons, pennants and streamers, shall be allowed in conjunction with a grand opening for each business. Said devices shall be in use for a period not to exceed fifteen (15) consecutive days and only upon the initial opening of each business. Attention-getting devices, with the exception of balloons, may be used in conjunction with a special promotion for a period not to exceed forty-five (45) days per calendar year. A temporary zoning approval is not required for an attention-getting device.

#### **H. Sign Regulations: Exempt, Prohibited, And Real Estate Signs.**

1. Exempt Signs. The following signs shall be exempt from the provisions of this UDC. However, setback and height requirements for all structures, where applicable, shall be in accord with the regulations of the particular zoning district in which the structure is located.
  - a. Official traffic or government signs, including memorial plaques and signs of historical interest.
  - b. Flags of any nation, government, or non-commercial organization.
  - c. Scoreboards on athletic fields.
  - d. Display window signs, not attached to a window, incorporated and related in content to such a display.
  - e. Temporary signs indicating a potential danger.
  - f. Public notices and legal notices required by law.

~~g. Window signs.~~

- h. Signs mandated by the federal, State, local or City government.
- i. "Now Hiring" banners under twenty-five (25) square feet and attached to a permanent structure.
- j. Holiday or seasonal displays. Property owners and tenants shall be permitted to put up and display decorations and displays celebrating or denoting religious holidays or events, the seasons of the year, State and national holidays, and similar occasions; provided, however, that this shall not allow balloons or similar devices prohibited herein; nor shall such seasonal displays be in place for a period longer than thirty (30) days. Should any seasonal display fail to meet these criteria, it shall be considered a sign under this Section. If any seasonal display conveys a commercial advertising message or bears the name of the business, it shall be considered a sign.
- k. Gravestones.
- l. Statues.
- m. Commemorative tablets and monument citations of less than ten (10) square feet that are an integral part of a permanent structure.
- n. Incidental signs, such as signs placed on vending machines, mailboxes, or service station pumps. Any sign such as a sandwich board with a commercial message that cannot be understood from a position off-site shall be considered incidental.
- o. Accessory signs not exceeding four (4) square feet in outline area, which have an accessory use with respect to the lot on which the sign is located.
- p. Identification signs which shall consist of lettering permanently attached to a wall or building, not exceeding four (4) square feet in outline area, which announce the name, and/or occupation of the building occupant and are absent of any illumination.
- q. Post Office Address.
  - 1) All buildings and structures having a post office address shall list the street number of such post office address on the front of the building or structure

in a type of sufficient size as to be clearly visible from any street adjacent to the property. In any case where the building or structure is not visible from the street that is adjacent to the property, or if the building is more than one hundred fifty (150) feet from the street adjacent to the property, the street number must be placed at some location on said property within fifty (50) feet of the adjacent street. This number need not always be on a mailbox, but a number on the mailbox on said property will satisfy the requirements of this statute. In the case of buildings or structures which are adjacent to more than one (1) street, the number shall be visible from the street to which the post office address corresponds.

- 2) All buildings or structures which are used for business, commercial, industrial, manufacturing or public purposes which have post office addresses shall list the street number of such post office address on the front of the building in a type of sufficient size [minimum three (3) inches, maximum twelve (12) inches] as to be clearly visible from a street adjacent to the property and on the rear of the building on the right edge of the building when facing the rear of the building and not less than six (6) feet nor more than eight (8) feet above the ground level.

2. Prohibited Signs. All signs not expressly permitted under this UDC or expressly exempt from regulation hereunder in accordance with the above Section are prohibited within the City of Chesterfield. Such signs shall include:

- a. Abandoned signs.
- b. Inflatables.
- c. Electronic message centers.
- d. Neon Prohibited. The use of visible neon tubing as a sign or for an architectural element, whether located on the exterior or interior of a wall or window, if visible from the street, is prohibited.

- 1) Exceptions. Neon window "OPEN" signs are permitted and are not subject to review by the Planning Commission. Said signs shall not exceed in aggregate an area equal to more than twenty percent (20%) of the window glass area on which it is located. Said signs may not utilize an intermittent light source or flash and/or blink.

- 2) Request For Exception. Requests for the allowance of a neon sign shall be made to the Planning Commission, which shall review the same in accordance with the following criteria:
  - a. (A written statement from an architect explaining the intended use of the neon lighting and its relationship to the project and surrounding environment shall be submitted to the Planning Commission demonstrating that the neon will encourage, promote, or reward good architecture and/or urban planning.
  - b. The light plan, including neon, shall be submitted for review to the Department and shall adhere to all conditions set forth in this Section of the UDC.
  - c. (In reviewing a request for such an exception, the Planning Commission shall consider safety, design and other factors deemed appropriate and shall verbally make a record relative to its specific determination.
  - e. Off-premises signs, other than those specified previously in this Section of the UDC.
  - f. Portable signs, unless used to convey public, not-for-profit, or civic information.
  - g. Projecting signs.
  - h. Rooftop signs.
  - i. Signs attached or painted on vehicles parked and visible from the public right-of-way, unless said vehicle is used in the normal day-to-day operations of a business.
  - j. Signs affixed to bus stop shelters or other similar structures.
3. Real Estate Signs. Real estate signs advertising the sale, rental or lease of a property or portion thereof may be erected on the property being offered. Each property may have no more than one (1) such sign facing each roadway on which the property has frontage. These signs may be either freestanding or attached wall signs or banners. Such signs shall be confined to the property in question and shall be removed within fourteen (14) days after the sale, rental or lease being advertised. A sign permit and MZA shall not be required for freestanding real estate signs which are not greater than twenty-five (25)

square feet in outline area.

- a. Total area of real estate signs in the "FP Flood Plain District, PS Park and Scenic District, NU Non-Urban District, AG Agricultural" or any residential district on vacant, undeveloped property containing five (5) or more acres in area shall not exceed thirty-two (32) square feet in outline area per frontage or eight (8) feet in height.
- b. Total area of other real estate signs located in the FP Flood Plain District, PS Park and Scenic District, NU Non-Urban District, AG Agricultural, and all residential districts shall not exceed sixteen (16) square feet in outline area per frontage or three (3) feet in height.
- c. Total area of real estate signs located in any commercial, industrial, or mixed use zoning district shall not exceed thirty-two (32) square feet in outline area per frontage or five (5) feet in height.

**I. Sign Regulations: Non-Conforming Signs. Information on non-conforming signs may be found in Article 07 of this UDC.**

**J. Sign Regulations: Real Estate Signs. The following provisions shall govern the erection of all real estate signs, together with their appurtenant and auxiliary devices with respect to size, number, height, location and construction.**

1. Real Estate Signs. Real estate signs advertising the sale, rental or lease of a property other than single-family residential property or portion thereof may be erected on the property being offered.
  - a. Signs Erected Prior To Occupancy Of A Building.
    - 1) Each property may have no more than one (1) such sign facing each roadway on which the property has frontage. These signs may be either freestanding, attached wall sign, or banner attached to the unoccupied building.
    - 2) Such signs shall be confined to the property in question and shall be removed within fourteen (14) days after the closing of the sale, rental or lease being advertised.

- 3) A sign permit shall not be required for freestanding real estate signs which are not greater than nine (9) square feet in outline area; however, an MZA is required for all real estate signs.
- 4) Real estate signs in the FP Flood Plain District, PS Park and Scenic District, NU Non-Urban District, or any residence district on vacant, undeveloped property containing five (5) or more acres in area shall not exceed thirty-two (32) square feet in outline area per facing. Signage for parcels less than five (5) acres shall not exceed nine (9) square feet in outline area per facing.
- 5) Real estate signs located in any commercial, industrial district, or mixed use zoning district shall not exceed thirty-two (32) square feet in outline area per facing.

b. Signs Erected After Occupancy Of A Building.

- 1) Each property may have no more than one (1) such sign facing each roadway on which the property has frontage. These signs shall be freestanding.
- 2) Such signs shall be confined to the property in question and shall be removed within fourteen (14) days after the closing of the sale, rental or lease being advertised.
- 3) Signs shall not exceed sixteen (16) square feet in outline area per facing.
- 4) Approval shall be required by the City of Chesterfield for all signage with the exception of those in the FP Flood Plain District, PS Park and Scenic District, NU Non-Urban District, or any residence district.

2. Application shall include:

- a. Information on how such sign coordinates with the overall sign package for the development.
- b. For real estate signs indicating property for rent or lease, a report shall accompany the application indicating the available lease space. Such reports shall be updated on a yearly basis (January 1) for as long as the sign is being requested.

3. Residential Real Estate Open House Sign On Public Streets. Residential real estate open



house directional signs may be placed in accordance with the restrictions on signs set forth in this Section. All residential real estate open house directional signs are subject to the following conditions:

- a. Size. The total face area of the signs shall not exceed three (3) square feet in size. No attention-getting devices shall be attached to any residential real estate open house directional sign.
- b. Height. The vertical distance measured from ground level to the highest point of such sign or sign structure or other support shall not exceed three (3) feet.
- c. Local Address. The sign shall only advertise a residence in the City of Chesterfield or for a property which can only be accessed through the City of Chesterfield.
- d. Limit. No more than six (6) signs per property for sale or lease shall be posted, and not more than one (1) sign at each required change of travel direction.
- e. Type. Signs shall be mounted either on stakes placed in the ground or with an A-frame support of sufficient weight so that the sign remains upright when mounted. Signs and any supporting structures shall be maintained in good condition at all times and shall be constructed out of quality materials normally used in professional signage.
- f. Location. No sign shall be placed, used or maintained in the following manners:
  - 1) On trees, traffic signs or utility poles, nor be placed in such a manner as to obstruct the view of any official public sign.
  - 2) In any location that obstructs the safe and convenient use by the public of any street, sidewalk, or curbside parkway area as determined by the City of Chesterfield.
  - 3) In any roadway area or center median area.
  - 4) At any location whereby the clear space for the passageway of pedestrians is reduced to a width that violates the Americans with Disabilities Act.
  - 5) On streets undergoing construction, nor on streets with special events.
  - 6) Within five (5) feet of any of the following: traffic signal; traffic sign;

designated bus stop sign; bus bench; or any other bench on the sidewalk.

- g. Residential real estate open house directional signs shall only be displayed between 9:00 A.M. and 3:00 P.M. on Tuesdays and from 12:00 P.M. to 6:00 P.M. on Sundays, and only on days of an open house.
- h. Identification Required. Every person who places or maintains a residential real estate open house sign on the streets of the City of Chesterfield shall have his/her name, address, and telephone number affixed to the signs.
- i. Any sign installed, placed, or deposited in violation of the provisions of this UDC may be summarily removed by the City.