



III.A.

690 Chesterfield Pkwy W • Chesterfield MO 63017-0760
Phone: 636-537-4000 • Fax 636-537-4798 • www.chesterfield.mo.us

Architectural Review Board Staff Report

Project Type: Site Development Section Plan

Meeting Date: September 10, 2015

From: Jonathan Raiche, AICP
Senior Planner

Cc: Aimee Nassif, Planning & Development Services Director

Location: 18350 Wings Corporate Drive

Applicant: Dial Architects, on behalf of D.F. Adams and Associates

Description: **Wings Corporate Estates, Lot 14:** A Site Development Section Plan, Landscape Plan, Lighting Plan, Architectural Elevations and an Architect's Statement of Design for a 1.61 acre tract of land zoned "PI" Planned Industrial District located on the east side of Eatherton Road, south of Wings Corporate Drive.

PROPOSAL SUMMARY

The request is for a 16,640 square foot office/warehouse building located at the corner of Wings Corporate Drive and Buzz Westfall Drive in the interior of the Wings Corporate Estates development. The subject site is zoned "PI" Planned Industrial District and is governed under the terms and conditions of City of Chesterfield Ordinance 2237. The exterior building materials will be comprised primarily of tilt-up concrete and glass with a prominent sloped roof.

HISTORY OF SUBJECT SITE

On February 6, 2006, the City of Chesterfield approved Ordinance 2237, which zoned the subject site from a "NU" Non-Urban District to a "PI" Planned Industrial District. Following the change of zoning, the City of Chesterfield approved the Site Development Concept Plan for Wings Corporate Estates on September 11, 2006. The Record Plat for the development was approved on February 4, 2008 to subdivide the development into twenty one (21) lots. Of the twenty-one (21) lots in the Wings Corporate Estates development, three (3) lots have been developed with an additional lot near completion as seen in Figure 1 on the next page.

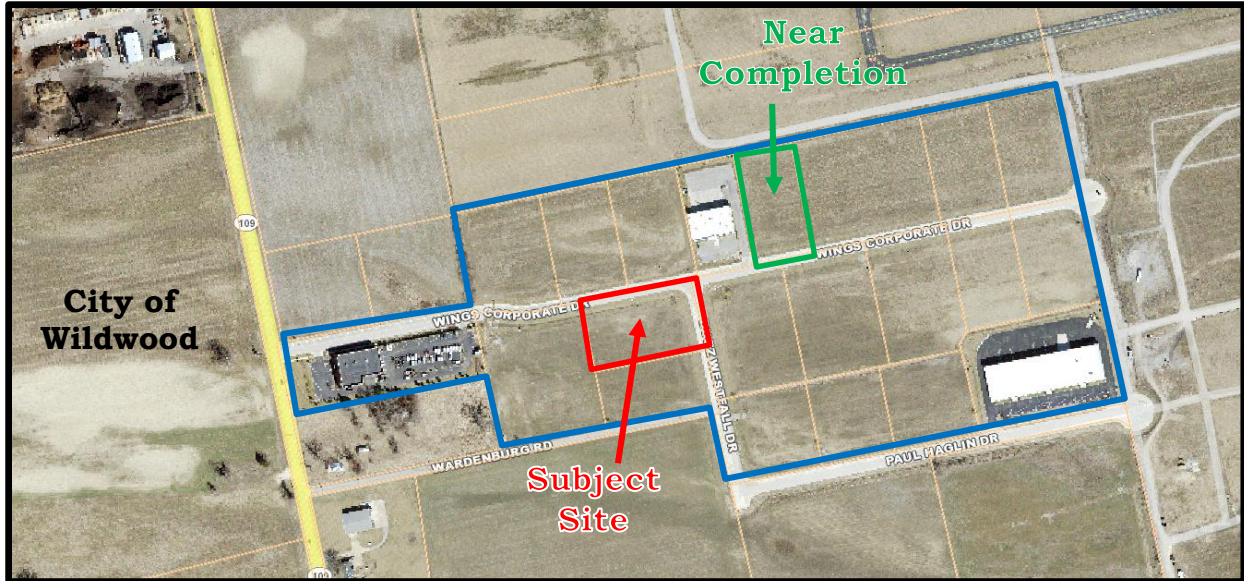

Figure 1

STAFF ANALYSIS

General Requirements for Site Design:

A. Site Relationships

The subject site is adjacent to and completely surrounded by other vacant lots in the Wings Corporate Estates development. While proposing a unique design, the proposed building uses similar materials as other buildings constructed in the area. The developer has indicated that his desire is to use the proposed train depot inspired design to match the transportation history of the site which will be discussed in more depth later in this report. The previously approved Lot 5 was the first to begin this transportation inspired design through the use of an airport hangar inspired design.

B. Circulation System and Access

The site proposes a total of two (2) access points which are both proposed as shared access drives. The first is located along the western property line off Wings Corporate Drive and the second is located along the southern property line off Buzz Westfall Drive. The proposal also provides a five (5) foot sidewalk on the south side of Wings Corporate Drive to provide pedestrian circulation which is consistent with the approved Concept Plan for this development.

C. Topography

The existing grade of the property is flat. Minimal changes to the existing topography are planned to accommodate for proposed improvements and proper stormwater drainage. Due to the flat topography of the site, the only retaining wall proposed is in the northeast corner around the drainage inlet.

General Requirements for Building Design:

A. Scale

The applicant is proposing a building of similar height and size as the other structures in the office park which meet the maximum forty (40) foot building height requirement. The design includes a single-story office / warehouse building similar to adjacent properties. The main façade of the proposed structure utilizes a large sloped roof and covered porch along the entire façade that provide a sense of human scale. The large porch extends to the west and wraps around the east façade to help continue this scale around three (3) sides of the building. The south elevation has a larger expanse of tilt-up concrete; however, the applicant has proposed small windows and dormers in the roof to help bring some sense of scale to this minor façade as well.

B. Design

As previously mentioned, the proposed development of Lot 14 is similar to other nearby buildings in both materials and design theme. There are two proposed entrances in the corners of the property with parking located along the north and east portions of the site. The parking will include porous pavement and there are also two (2) small bio-retention areas to the west of the proposed building for stormwater purposes. The loading area for this site is proposed on the western façade along with the dumpster enclosure. The applicant has proposed plantings along the building and dumpster enclosure as well as along the street that will provide screening for this area. In addition to the plantings, the proposed front porch will extend toward the west from the corner of the building and will also assist in providing a visual element to screen the loading area.

As previously mentioned, the applicant has designed this building with a train depot as the inspiration. The low sloped roof with significant dormers, in conjunction with the wrap-around covered porch, are strong architectural elements used along the north, east, and west facades as seen in Figure 2 on the next page. These elements provide articulation along the façade which provides visual interest. The proposal also indicates ground-mounted HVAC equipment on the south side of the building that will be screened on all sides by proposed landscaping.

C. Materials and Color

As mentioned previously, the building will be comprised of tilt-up concrete and glass with a prominent sloped roof. The developer has chosen a neutral color palette with bronze and taupe paint utilized on the concrete and bronze utilized for the various window and wood trim elements located on the porch. This color palette is consistent with the existing building in the development. The wood trim brackets and posts, along with the scale of the porch, help create the train depot inspired design.



Figure 2

D. Landscape Design and Screening

The proposal includes landscaping required by the City of Chesterfield Tree Preservation and Landscape Requirements Ordinance. The plantings include street trees along Wings Corporate Drive and Buzz Westfall Drive, as well as plantings dispersed throughout the site along each side of the building which includes screening for two different ground mounted equipment locations. The proposed plantings also enhance the proposed covered porch and parking island areas to create an aesthetically pleasant area for pedestrians utilizing these areas. The dumpster will be screened by a six (6) foot tall concrete panel enclosure. The concrete panels will be painted to match the building and will be screened by proposed plantings on two sides.

E. Signage

Signage is not part of the proposal before Architectural Review Board and will be reviewed by Staff.

F. Lighting

The plan proposes four (4) light standards in the parking areas and one (1) street light standard in the northeast corner of the site as required by the approved Improvement Plans for this development. The street light proposed is the same fixture that has been utilized on adjacent sites. Additionally, there are seven (7) wall-mounted, shoebox type fixtures located on three (3) of the building facades. Four (4) of these wall-mounted fixtures are to illuminate the building entrances with three (3) provided on the south elevation. All of the light standards and wall-mounted fixtures

are LED area lights which are fully shielded, full cut off optics and adhere to the City of Chesterfield Lighting Standards.

DEPARTMENTAL INPUT

Staff has reviewed the Site Development Section Plan, Landscape Plan, Lighting Plan, Architectural Elevations and Architect's Statement of Design and finds that the plans are in compliance with City Code. Staff requests action on the Site Development Section Plan, Landscape Plan, Lighting Plan, Architectural Elevations and Architect's Statement of Design for Wings Corporate Estates, Lot 14.

MOTION

The following options are provided to the Architectural Review Board for consideration relative to this application:

- 1) "I move to forward the Site Development Section Plan, Landscape Plan, Lighting Plan, Architectural Elevations and Architect's Statement of Design for Wings Corporate Estates, Lot 14, as presented, with a recommendation for approval (or denial) to the Planning Commission."
- 2) "I move to forward the Site Development Section Plan, Landscape Plan, Lighting Plan, Architectural Elevations and Architect's Statement of Design for Wings Corporate Estates, Lot 14, to the Planning Commission with the following recommendations..."

Attachments

1. Architectural Review Packet Submittal

Lot-14

*Wings Corporate Estates
18350 Wings Corporate Drive
Chesterfield, Missouri*

September 1, 2015



Owner:
D.F. Adams & Associates, Inc.

Architect:
David W. Dial Architects, P.C.

Civil Engineer:
**The Clayton Engineering
Company**



ARCHITECTURAL REVIEW BOARD
Project Statistics and Checklist

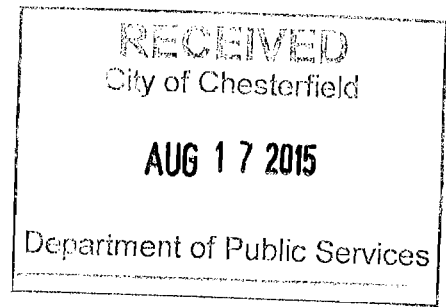

Date of First Comment Letter Received from the City of Chesterfield _____

Project Title: Wings Lot-5 Location: 18350 Wings Corporate Drive

Developer: D.F. Adams & Assoc., Inc. Architect: David W. Dial Architects, P.C. Engineer: The Clayton Engineering Co.

PROJECT STATISTICS:

Size of site (in acres): 1.61 acres Total Square Footage: 16,640 S.F. Building Height: +/-33'-0"

Proposed Usage: Speculative Office/Warehouse

Exterior Building Materials: Tilt-up Concrete

Roof Material & Design: Asphalt Shingles over sloped roof

Screening Material & Design: Trash Enclosure si titlt-up concrete panels

Description of art or architecturally significant features (if any): _____
Historic Train Station design; Extended canopy with decorative brackets

ADDITIONAL PROJECT INFORMATION:

Checklist: Items to be provided in an 11" x 17" format

- Color Site Plan with contours, site location map, and identification of adjacent uses.
- Color elevations for all building faces.
- Color rendering or model reflecting proposed topography.
- Photos reflecting all views of adjacent uses and sites.
- Details of screening, retaining walls, etc.
- Section plans highlighting any building off-sets, etc. (as applicable)
- Architect's Statement of Design which clearly identifies how each section in the Standards has been addressed and the intent of the project.
- Landscape Plan.
- Lighting cut sheets for any proposed building lighting fixtures. (as applicable)
- Large exterior material samples. (to be brought to the ARB meeting)
- Any other exhibits which would aid understanding of the design proposal. (as applicable)
- Pdf files of each document required.

dial architects

14364 Manchester Road
Manchester Missouri 63011
636 230 0400

August 31, 2015

City of Chesterfield
Department of Planning
690 Chesterfield Parkway West
Chesterfield, Missouri 63017-0760

Members of the Architectural Review Board

Re: Architectural Statement
 Submittal for Approval of New Facility on Lot 14.
 Wings Corporate Estates, Lot 14 – 18350 Wings Corporate Drive

General Requirements for Site Design

This project consists of a single-story speculative office/warehouse building designed for a single tenant. The site is located at the corner of Wings Corporate Drive and Buzz Westfall Drive near Eatherton Road on the far west side of Chesterfield Valley in the Wings Development. The owner of this development is also the owner of this building. It is his intent to create an upscale business park by creating ‘specialty design’ buildings. This building is the second building of its kind in the park, but the fourth building in the park as a whole.

As you can see from the photos in this packet, the rectangular site is treeless and generally flat other than the drainage ditch and is otherwise featureless. The building is strategically located on the site to be compatible with the existing drainage system for the development.

The approved concept plan for the entire development shows a 5’ wide side walk on the south side of Wings Corporate Drive to provide pedestrian circulation. While we cannot control future development of neighboring sites, this specific site design forces shared entrances with future neighbors on each side. This concept is key to the park owners desires for this overall development.

We are not proposing the use of fencing nor retaining walls at this time.

Landscaping is designed per city ordinance in a similar fashion to the adjacent developments. Please see attached landscape plan.

General Requirements for Building Design

The owner of this facility, being a long time and current resident of the City of Chesterfield, places a high priority on the appearance of his facility and has played a major role in the design of this facility.

The intent of the design is to represent the spirit of transportation with the nearby airport and the old Centaur train station. The front (north) elevation is articulated with a large overhanging canopy with decorative posts and exposed brackets, glass, reveals and large dormers with operable windows. The canopy brackets and windows create rhythmically pleasing patterns accented with colors and opposing shapes to add depth and a sense of place. The full length canopy and railway platform extending around the street corner elevations addresses the intersection and encourages one to explore the building further.

The building will utilize an earth tone color, single hung operable windows and earth tone colored asphalt shingle sloped roof with dormers. The colors, glass and metal items are juxtaposed on the façades of the building to create a very nice overall building design. These include a main building color of a warm taupe and darker accent color of similar nature. In addition, the large railway platform canopy is designed to cover the northern and eastern facing walk to prevent the buildup of ice and snow in inclement weather. So the intended office area will receive the strong morning eastern light and the diffuse northern light provided by the compass orientation.

All sides of this building are treated in a historically accurate fashion. We have not only 'designed' the street elevations. The building materials are the same as all of the other buildings in this park, but are being used in more design appropriate ways to deliver an aesthetically pleasing solution. A special elastomeric coating designed specifically for concrete will protect the concrete panels. The sloped roof is covered with dark architectural asphalt shingles.

The windows for this project, in keeping with its strong design theme, are operable single-hung energy compliant windows. We have used the glass as an effective design element in the elevational articulation.

The design is respectful of the surrounding development in general and is harmonious in scale, material, and color. Nearby buildings are also constructed of tilt-up concrete and/or earth tone colors and materials similar to ours. Signage will be applied to the building in a similar fashion as adjacent buildings.

Site lighting is planned to be two light standards in the front of the building along Wings Corporate Drive, two light standards at the side of the building along Buzz Westfall Drive with wall-mounted, shoebox type fixtures on the west and south elevations of the building that will not shine off of the property in an unnecessary fashion and lighting on either side of the main building entry.

Please see the site development section plan for drainage information.

The proposed HVAC system is planned to be ground mounted.

Specific Requirements for the Chesterfield Valley

As stated above we encompass the building with reveals and colors for continuity while highlighting the visible front with glass. The trash receptacle will be screened from public view with tilt-up concrete to coordinate with the building.

The electrical service will be provided by a new transformer located along the south/east side of the property south of the building and will receive vegetation to screen the units. All utilities to this building are underground.

I-64/US-40 is to the north of this property and is not readily visible from the property. Automobile parking is north and east of the building and the service/loading area is on the west side of the building.

Street lighting is included in this project to match the existing industrial park street lighting and is located to the east of the building along Buzz Westfall Drive.

It remains our intention to provide a design that will enhance the local environment while blending with the building types already in Wings Corporate Estates. The owner is excited about providing a new quality designed facility for the City of Chesterfield.

Thank you for your assistance.

As required, building materials will be brought to the ARB meeting and will include:

- Glass and frame sample
- Color samples of the concrete coatings
- Asphalt Shingle Roof

End of Architects Statement

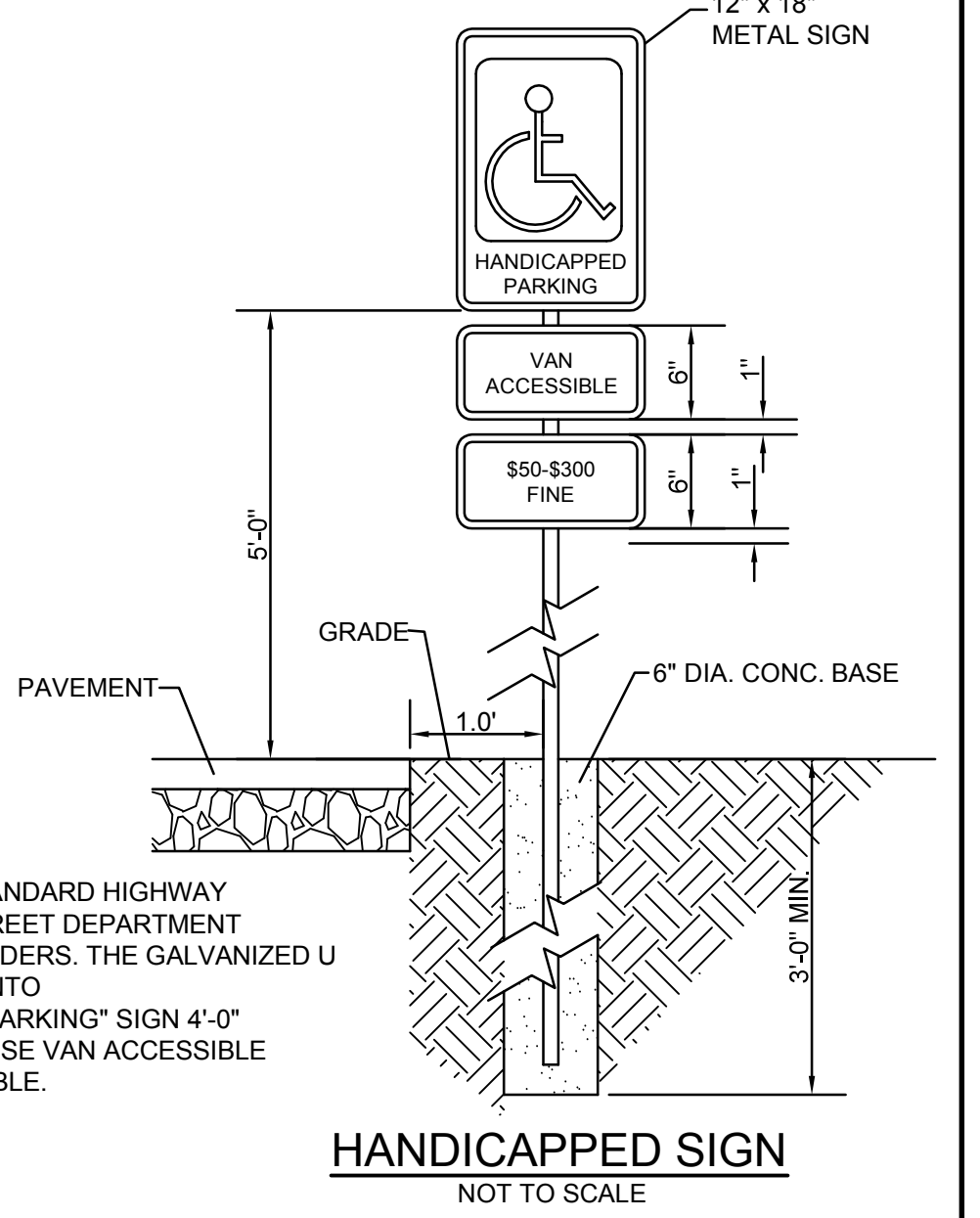
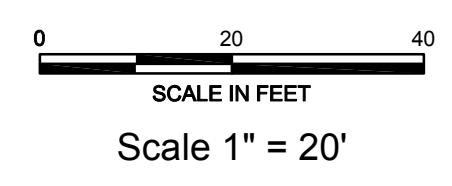
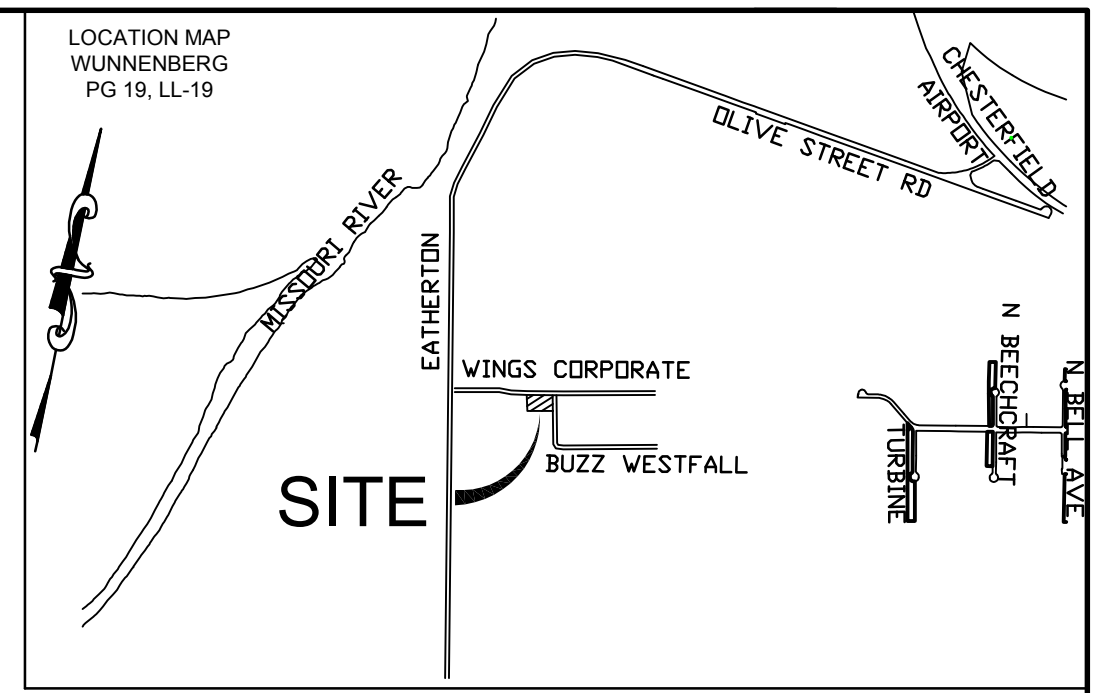
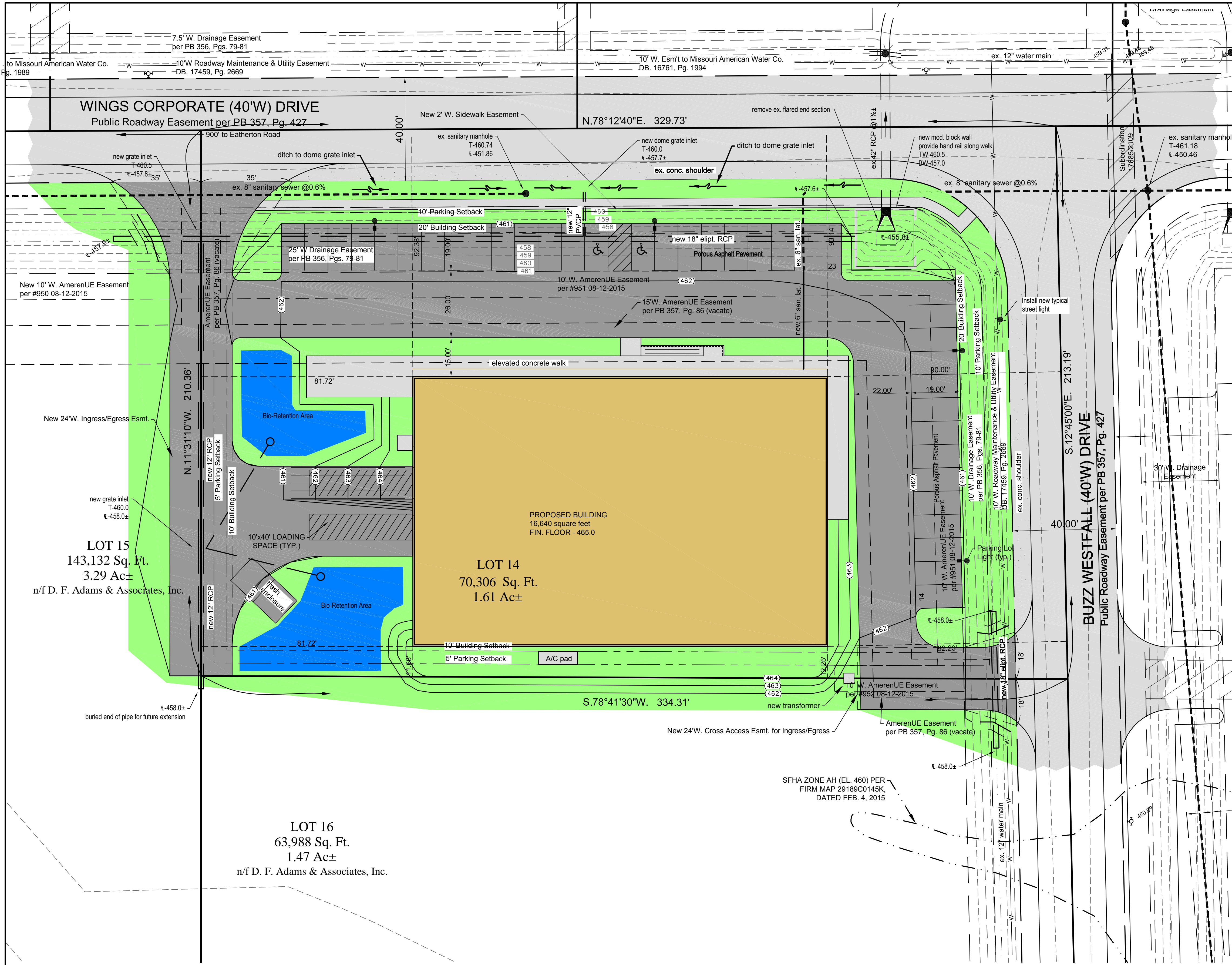

STANDARD SIGN FACE, STANDARD HIGHWAY DEPARTMENT, OR CITY STREET DEPARTMENT GAUGE. LETTERS AND BORDERS: THE GALVANIZED U CHANNEL POST, SET 3'-0" INTO GRADE. SET BOTTOM OF "PARKING" SIGN 4'-0" ABOVE FINISHED GRADE. USE VAN ACCESSIBLE SIGN ONLY WHEN APPLICABLE.

NOTES:

1. Permission to grade on adjacent property will be acquired in the form of a letter statement from the adjoining property owner stating their permission to grade. New cross access easements for ingress and egress within the area of the shared driveways and approach aprons shall be signed by the respective property owners and recorded in the St. Louis County records.
2. AmerenUE has not installed underground electric service to the development site. The easement granted to AmerenUE for the installation of underground electric service may be relocated prior to installation. The owner will coordinate with AmerenUE for installation of the underground electric service and relocation of easements, as needed.
3. A Floodplain Development Permit will be required as part of the improvement plan submittal and an elevation certificate will be required prior to occupancy. The required new subdivision street light shall be incorporated as part of the existing subdivision street light agreement.
4. Storm water runoff from the pavement of Wings Corporate Drive shall be collected in some manner prior to running over the proposed concrete sidewalk and discharged to an appropriate drainage facility to prevent the possibility of runoff collecting on the walk and creating a slip possibility.

Underground facilities, structures & utilities have been plotted from available surveys, records & information, and therefore, do not necessarily reflect the actual existence, nonexistence, size, type, number of, or location of these facilities, structures, & utilities.

The Contractor shall be responsible for verifying the actual location of all underground facilities, structures, & utilities, either shown or not shown on these plans. The underground facilities, structures, & utilities shall be located in the field prior to any grading, excavation or construction of improvements. These provisions shall in no way absolve any party from complying with the Underground Facility Safety and Damage Prevention Act, Chapter 319, RSMO.

The signed and sealed original of this drawing is on file at the offices of The Clayton Engineering Company, Inc. The signed and sealed original is the official document and shall take precedence over any digital version.

Call Before you DIG
TOLL FREE
1-800-344-7483
MISSOURI ONE-CALL SYSTEM INC.

SLC H&T No.
MSD P-
BASE MAP 18W

Copyright 2015
Clayton Engineering Co.
All Rights Reserved

1	06-19-15	erd	revisions per Chesterfield comments
---	----------	-----	-------------------------------------

REVISIONS

SITE DEVELOPMENT SECTION PLAN
SITE PLAN

18350 Wings Corporate Drive
Prepared for:
D. F. ADAMS & ASSOCIATES, INC.
16441 Walnut Rail Road
Chesterfield, MO 63005
(314) 434-2888

the clayton engineering company, inc.
ENGINEERS • SURVEYORS • PLANNERS
11920 WESTLINE INDUSTRIAL DRIVE
ST. LOUIS, MISSOURI 63146
(314) 892-8888 FAX: (314) 892-8888 claytoneng.com
Mo. Cert. of Authority - Prof. Engineering #000067 & Prof. Surveying #000014

Designed _____
Drawn _____
Checked _____
Date _____
Project Number **15006**
Sheet Number **2** of _____

PLOTTED: 03/27/15 11:29 BY: ERD



LOOKING NORTH



LOOKING EAST



LOOKING SOUTH



LOOKING WEST

Structural Engineer:
 Civil Engineer:
 Mechanical/Electrical/Plumbing & Fire Protection Engineers:

New Building for:
Wings Corporate Estates - Lot 14
 Chesterfield, MO 63005

ISSUE DATES:

PRELIMINARY DESIGN:	03-06-2015
PRELIMINARY DESIGN:	03-13-2015
CITY SUBMITTAL:	04-29-2015
CITY COMMENTS:	06-08-2015
CITY COMMENTS:	06-13-2015



STATE OF MISSOURI REGISTERED ARCHITECT:
 DAVID W. DIAL - LICENSE NUMBER A-7331
 DAVID W. DIAL ARCHITECTS, P.C.
 ARCHITECTURAL CORPORATION #200049091

THE ARCHITECT'S SEAL AFFIXED TO THIS SHEET INDICATES THAT THE NAMED ARCHITECT HAS PREPARED OR DIRECTED THE PREPARATION OF THE MATERIAL SHOWN ONLY ON THIS SHEET. OTHER DRAWINGS AND DOCUMENTS, NOT EXHIBITING THIS SEAL, SHALL NOT BE CONSIDERED PREPARED BY OR THE RESPONSIBILITY OF THE UNDERSIGNED.

dial architects
 14364 Manchester Road • Manchester, Missouri 63011
 636 230 0400 www.dialarchitects.com

SHEET NUMBER:
ELEVATIONS
 PROJECT NUMBER: 15020 DATE: 04-29-2015

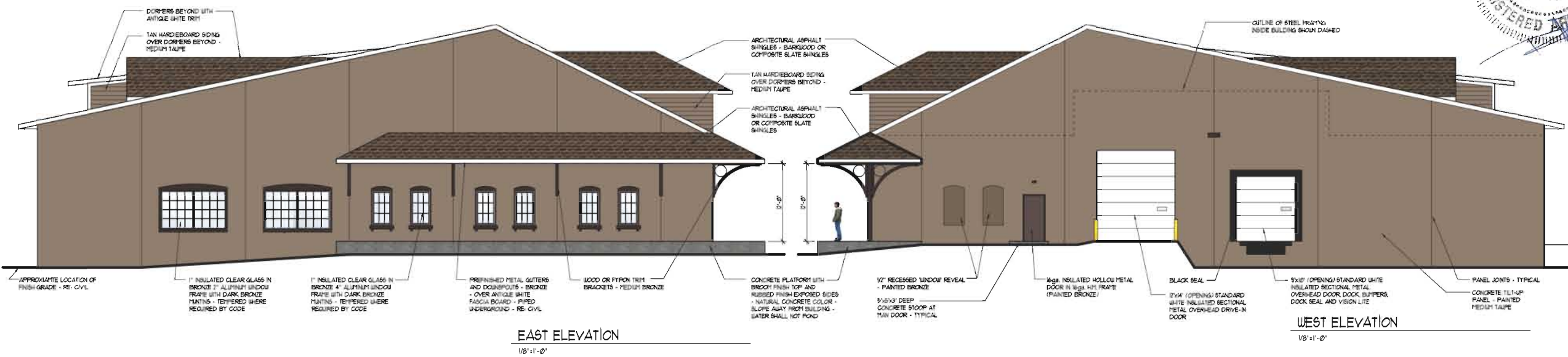
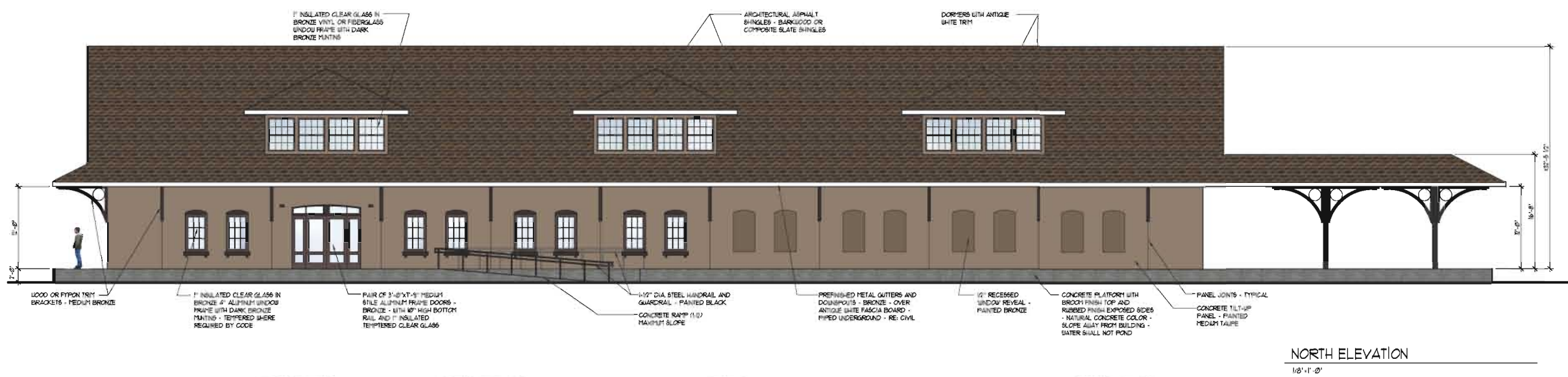



DIAL
ARCHITECTS

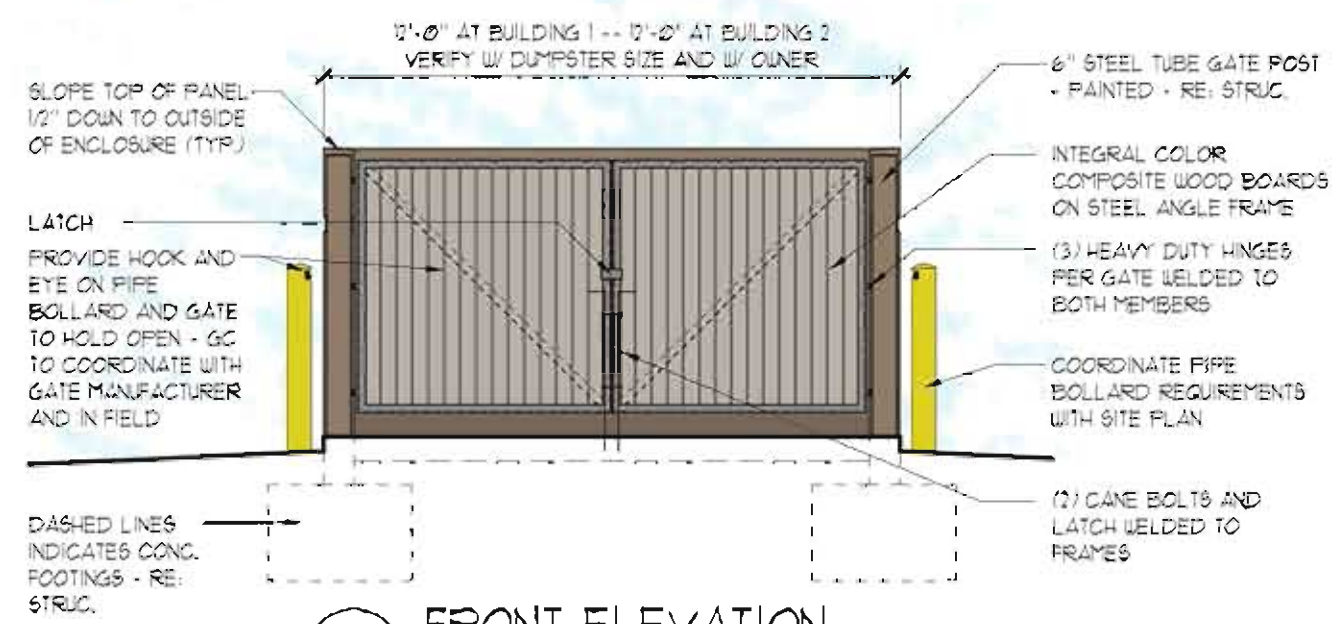
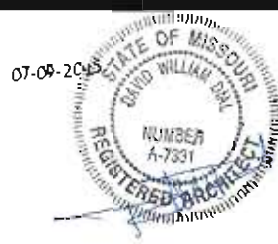

3 FRONT ELEVATION
1/4" = 1'-0"

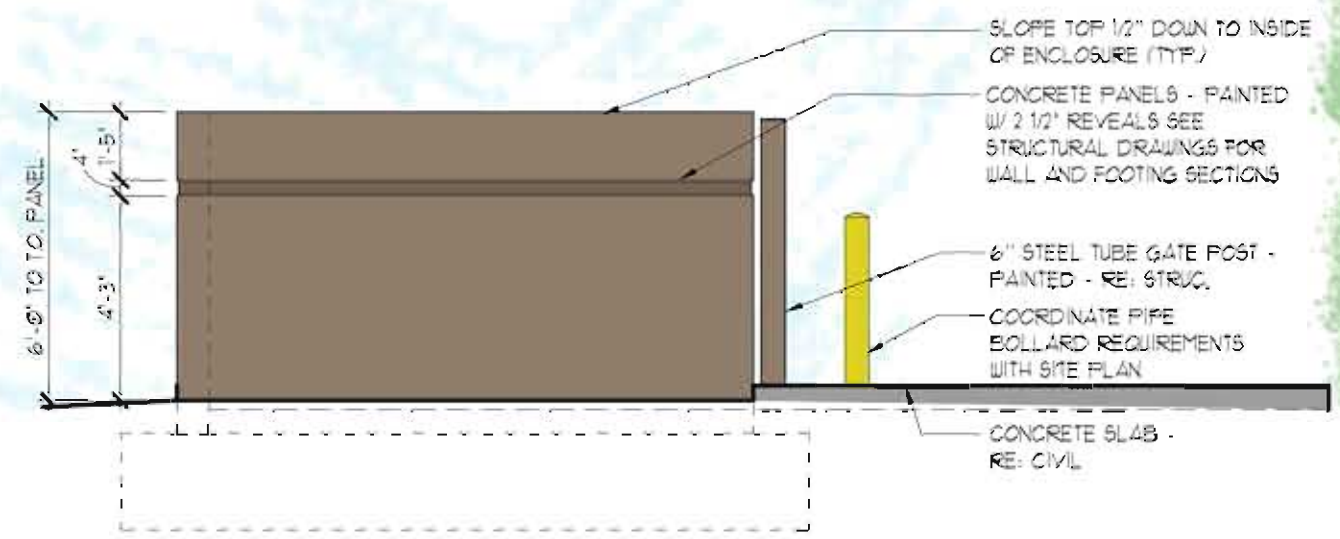

2 SIDE ELEVATION
1/4" = 1'-0"

NOTE:
DUE TO VARYING DUMPSTER SIZES, THE G.C. MUST VERIFY THE SIZE OF THIS ENCLOSURE WITH THE OWNER AND/OR THE DUMPSTER SIZES INTENDED TO BE USED TO INSURE PROPER FIT.

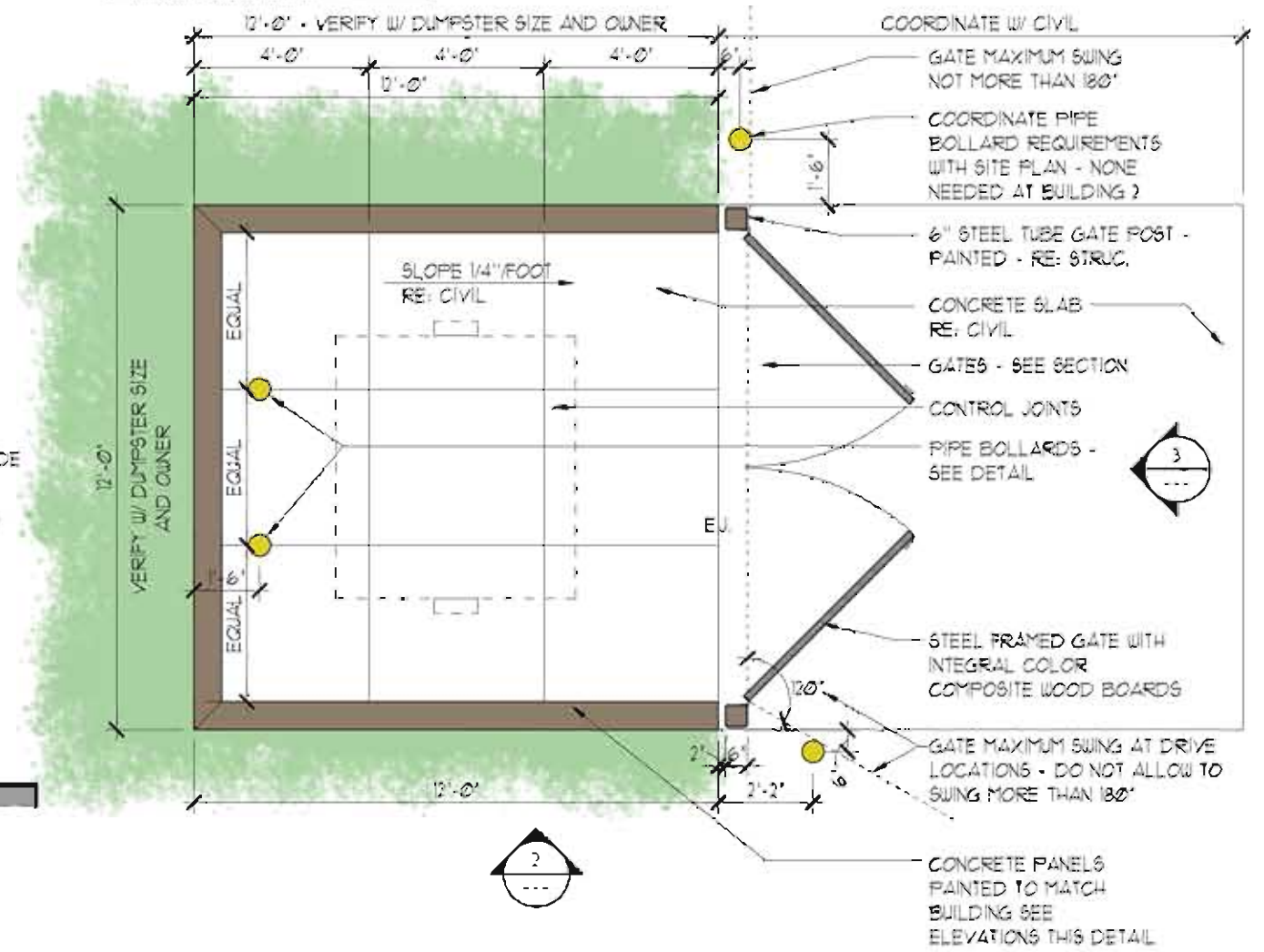

1 DUMPSTER PLAN
1/2" = 1'-0"

New Building for:

Wings Corporate Estates - Lot 14

Chesterfield, MO 63005

DATE: 07-09-15
DDA PROJECT NUMBER: 15020
DUMPSTER DETAILS

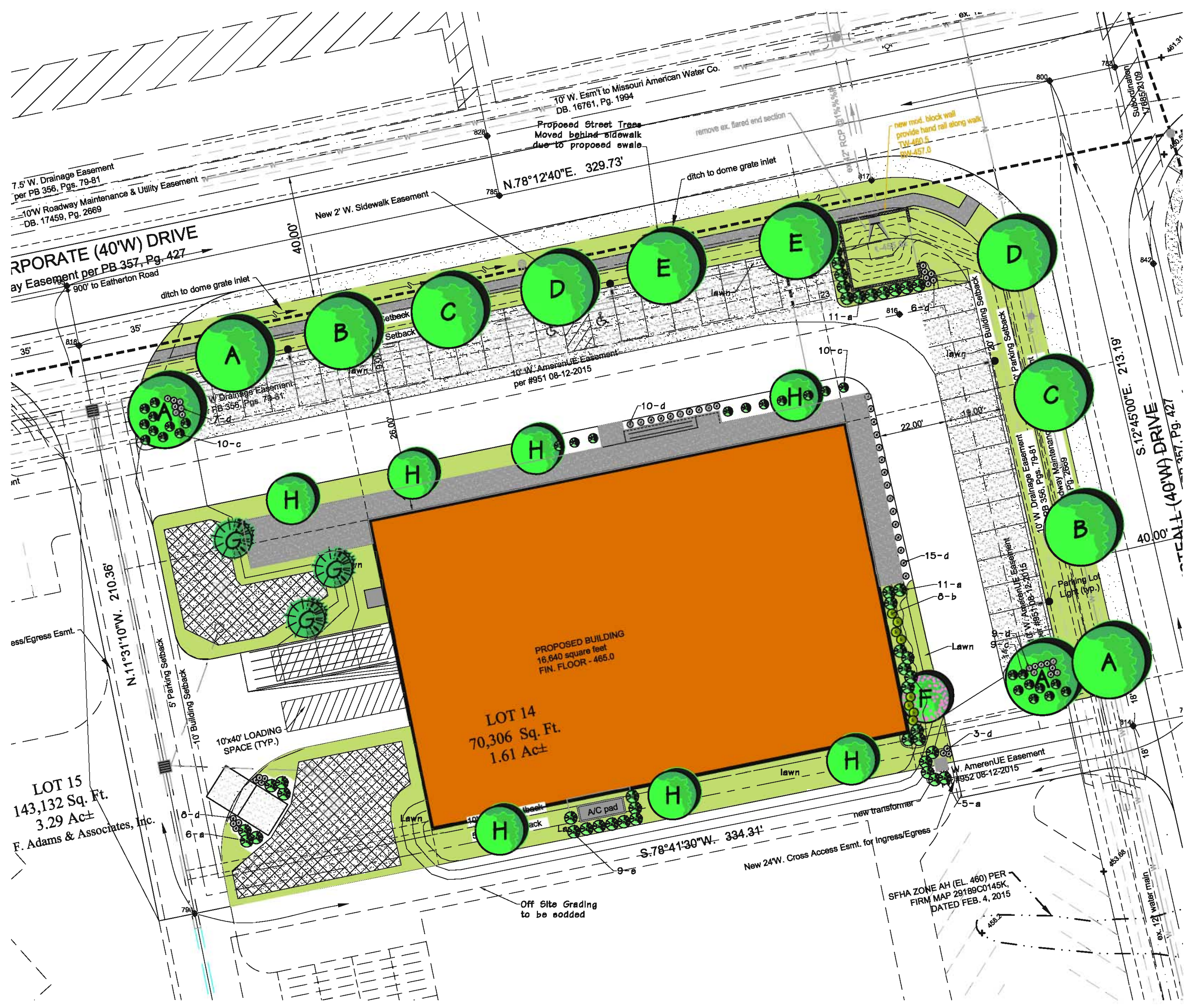

Landscape Plan
SCALE 1"=20'

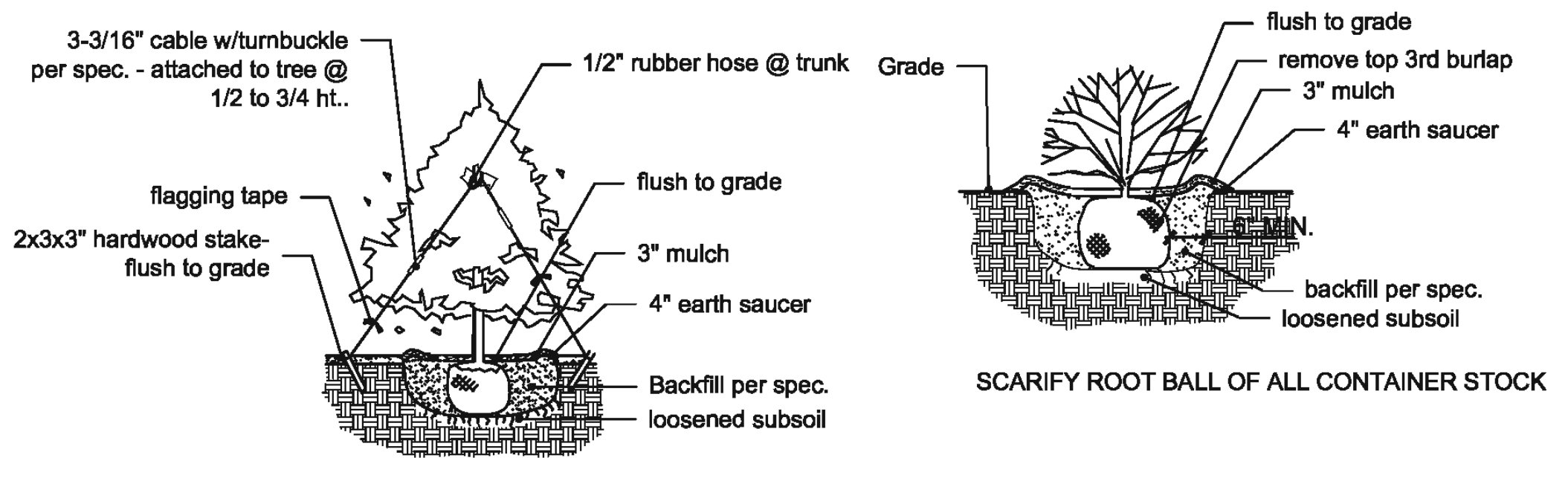

TYPICAL EVERGREEN PLANTING

TYPICAL SHRUB PLANTING

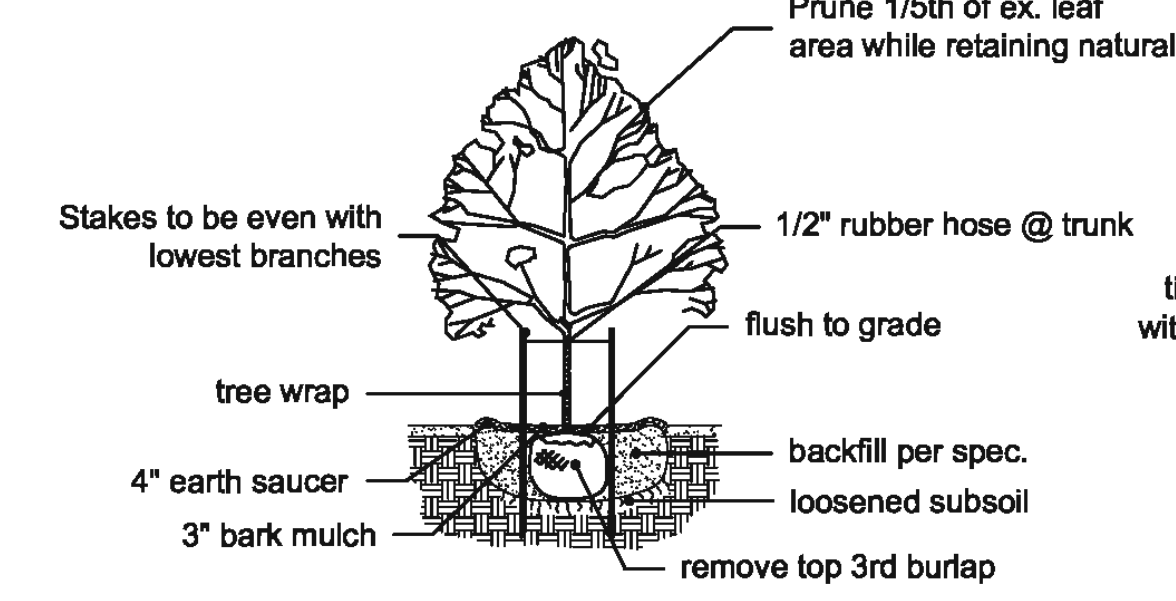

CANOPY TREE PLANTING

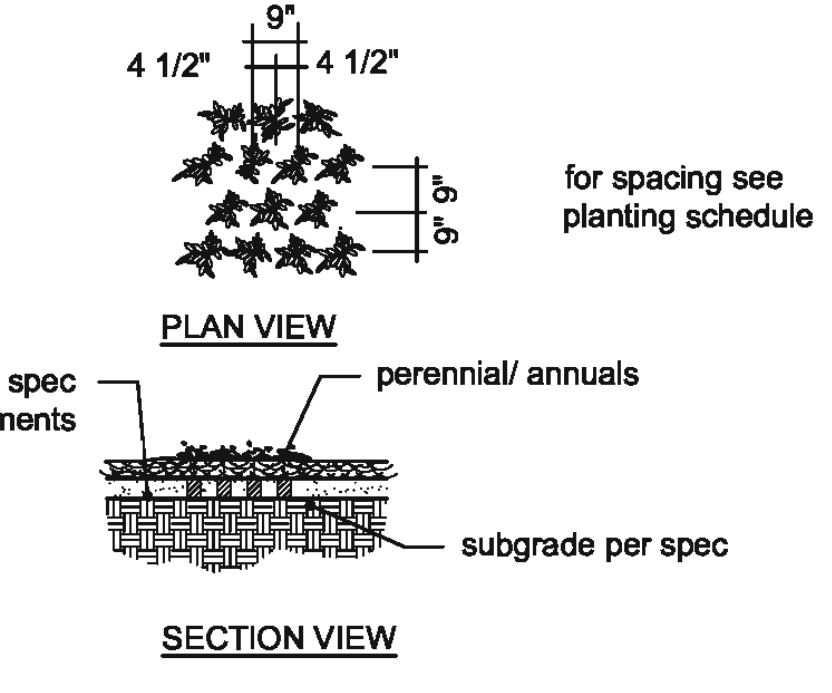

TYPICAL PERENNIAL PLANTING

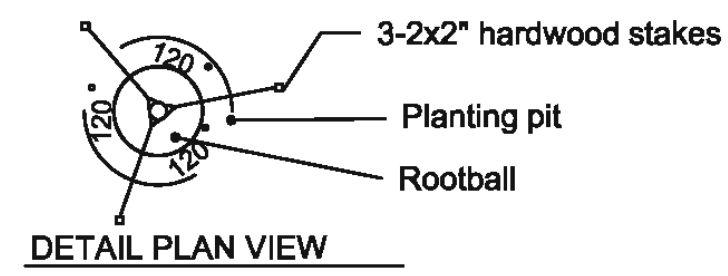

DETAIL PLAN VIEW

PLANTING SCHEDULE						
SYMBOL	QUANTITY	BOTANICAL NAME	COMMON NAME	SIZE	MATURE HEIGHT	TYPE
A	4	Platanus x acerifolia	London Planetree	2 1/2"	45'+	Fast Growing
B	2	Tilia americana	American Linden	2 1/2"	45'+	Medium Growing
C	2	Quercus bicolor	Swamp White Oak	2 1/2"	45'+	Medium Growing
D	2	Quercus imbricaria	Shingle Oak	2 1/2"	45'+	Medium Growing
E	2	Acer rubrum 'Red Sunset'	Red Sunset Red Maple	2 1/2"	45'+	Fast Growing
F	1	Cercis canadensis	Red Bud	2 1/2"	25'+	Fast Growing
G	3	Taxodium distichum	Bald Cypress	6'	45'+	Medium Growing
H	7	Carpinus betulus 'Fastigiata'	Upright European Hornbeam	2 1/2"	35'+	Slow Growing
a	33	Ilex glabra 'Shamrock'	Shamrock Inkberry	2-3'		3' O.C.
b	8	Itea virginica	Sweetpire	18-24"		2.5' O.C.
c	29	Juniperus horizontalis 'Plumosa'	Compact Andorra Juniper	18-24"		3' O.C.
d	64	Calamagrostis a. 'Karl Foerster'	Karl Foerster Grass	1 gal		2' O.C.
e	9	Thuja occidentalis 'Emerald'	Emerald Arborvitae	4-6'		4' O.C.
Water quality plantings to be selected						

GENERAL NOTES:

- 1) Openpace ratio is 31.6%. Total Site 70,306 SF/Open Space 22,243 SF
- 2) Street trees Req. - 465 lf/50 ft = 9.7 or 10 street trees
- 3) All street trees will be located at least 3' from proposed curb.
- 4) All street trees will be located at least 10' from all storm sewer structures.
- 5) All street trees will be located at least 25' from all street lights, signs, and intersections.
- 6) Street Trees along Wings Coporate Drive moved behind sidewalk due to proposed swale.
- 7) All turf areas will be sodded.
- 8) An in-ground irrigation system will be provided.

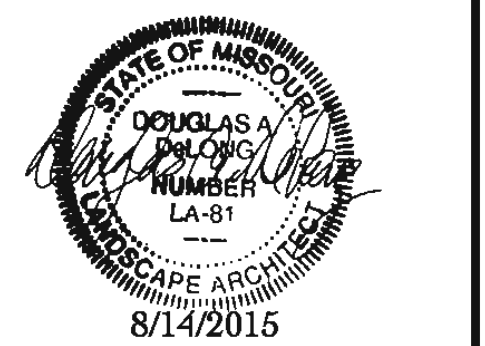

Douglas A. DeLong, Landscape Architect LA-81
Consultants:

Wings Corporate Estates-Lot 14
Chesterfield, Mo

Dial Architects

Revisions:

Date	Description	No.
6/18/15	City Comments	1
7/24/15	Site Revisions	2
8/14/15	Site Revisions	3

Drawn: BAD
Checked: DAD

Douglas A. DeLong
Landscape Architecture, LLC
7620 West Bruno Ave
St. Louis, MO. 63117
(314) 346-4856
delong.la@gmail.com
Missouri State Certificate of Authority: 0015001046

Sheet Title: Landscape Plan
Sheet No: L-1
Date: 4/27/2015
Job #: 105.014



Site & Area
EcoForm



Project _____
 Location _____
 Cat No _____
 Type _____
 Qty. _____
 Notes _____

EcoForm combines economy with performance in an LED area luminaire. Capable of delivering up to 20,000 lumens or more in a compact, low profile housing, EcoForm offers a new level of customer value. EcoForm features an innovative retrofit arm kit, simplifying site conversions to LED by eliminating the need to drill additional holes in most existing poles. Integral control systems, including motion response and wireless controls are available for further energy savings during off peak hours.

Ordering guide

example: ECF-APD-MRO-1-4-75LA-NW-120-NP-LF

Prefix	Controls	Mounting	Optics	LED Wattage	Color Temp	Voltage	Finish	Options
ECF								
ECF EcoForm	— Standard luminaire (leave blank) DIM 0-10V Dimming APD ¹ Auto Profile Dimming APD-MRO ² Auto Profile Dimming and Motion Response Override pole mounted motion sensor APD-MRI ^{2,3} APD with Motion Response Override luminaire sensor MRI ^{2,3} Motion Response at 50% low luminaire sensor MR50 ² Motion Response at 50% low, pole mounted sensor LimeLight Wireless Controls LLC2 ^{1,5} #2 lens for 8-15' mounted heights LLC3 ^{1,5} #3 lens for 15-25' mounted heights LLC4 ^{1,5} #4 lens for 25-40' mounted heights	1 Standard 2 2@180 2@90 2@90 3 3@90 3@120 3@120 4 4@90 WS Wall mount including surface conduit rear entry permitted MA Mast Arm Fitter (requires 2-3/8" O.D. Mast Arm)	2 Type 2 3 Type 3 4 Type 4 5 Type 5	530 mA 55LA-3253 ¹ 75LA-4853 100LA-6453 700mA 70LA-3270 105LA-4870 135LA-6470 1050mA 105LA-321A ¹ 160LA-481A 215LA-641A	CW Cool White 5,700K 70 CRI (nominal) NW Neutral White 4,000K 70 CRI (nominal) WW ⁴ Warm White 3,000K 70 CRI (nominal)	120 120V 208 208V 240 240V 277 277V 347 347V 480 480V UNV 120-277V 50hz/60hz HVU 347-480V 50hz/60hz	BRP Bronze Paint BLP Black Paint WP White Paint NP Natural Paint OC Optional Color Specify optional color or RAL (ex OC-LGP or OC-RAL7024) SC Special color Specify, must supply color chip Requires factory quote	TL Tool-Less entry and driver removal hardware TB ¹ Terminal Block IS ⁶ Internal Shield LF ⁷ Line Fusing LFC ⁷ Line Fusing for Canada PC ^{5,7,8} Receptacle with Photocell (Includes PCRS) PCB ^{5,7,8} Photocell Button PCR5 ^{5,11} Photocell Receptacle only with 2 dimming connections PCR7 ^{5,12} Photocell Receptacle only with 2 dimming and 2 auxiliary connections RAM Retrofit Arm Mount kit PTF2 ⁹ Pole Top Fitter for 2 1/2" - 3" Tenon PTF3 ⁹ Pole Top Fitter for 3" - 3 1/2" Tenon PTF4 ⁹ Pole Top Fitter for 3 1/2" - 4" Tenon RPA ¹⁰ Round Pole Adapter for 3" - 3 9" O.D. BD Bird Deterrent (field installed only)

1 Available in 120V-277V Voltages only (UNV, 120, 208, 240 & 277)
 2 MR50 and APD-MRO luminaires require one motion sensor per pole, ordered separately. See page 2 for Accessories Available in 120V or 277V only.
 3 ECF-MRI requires outboarded sensor when used with Terminal Block (TB) Option
 4 Contact factory for lead times on warm white
 5 LLC2/LLC3/LLC4 Wireless Controls are not configurable with PC/PCB/PCR5/PCR7 Options See page 7-8 for more info
 6 Not configurable with Type 5 (5) Optics
 7 Not configurable with 120-277V (UNV) Voltage. Voltage must be specified
 8 Not configurable with 480V (480) Voltage.
 9 Not configurable with 3@120 (3@120) Mounting
 10 No adaptor required for 4" round poles RPAs provided with Black Paint standard
 11 Works with 3-pin or 5-pin NEMA photocell/dimming device
 12 Works with 3-pin or 5-pin NEMA photocell/dimming device and auxiliary connections are not connected (for future use only)
 13 If ordered with DIM, APD, MRI, MR50, APD-MRI, APD-MRO, dimming will not be connected to NEMA receptacle

ECF EcoForm

Site & Area

EcoForm Accessories (order separately)

FS1R-100

MR hand held programmer

For use with 'MRI' motion response when field programming is required. If desired, only one is needed per job.

MS-A-120V

120V Input Area Motion Sensor
For MR50 (Motion Response) or APD-MRO (Automatic Profile Dimming with Motion Response Override)

MS-A-277V

277V Input Area Motion Sensor
For MR50 (Motion Response) or APD-MRO (Automatic Profile Dimming with Motion Response Override)

Note: Motion Sensors are ordered separately, with one (1) motion sensor required per pole location for MR50 or APD-MRO luminaires. See Luminaire Configuration Information on page 5 for more details. Area motion sensor color is Arctic White. MRI and APD-MRI luminaires include an integral motion sensor.

EcoForm Drill Template (standard arm mount)

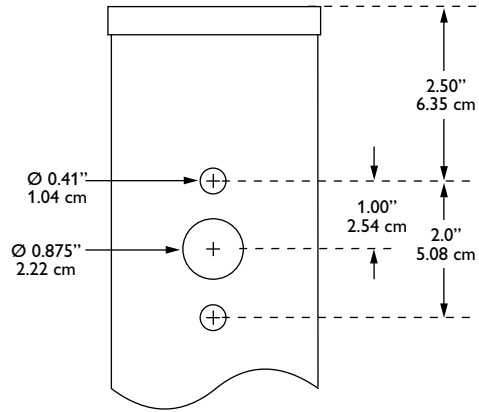

LED Wattage and Lumen Values (standard EcoForm luminaire)

Order Code (standard units)	Array Quantity	Total LEDs	LED Current (mA)	Average System Watts ¹	LED Selection	Initial Lumens ²			
						2 Type 2	3 Type 3	4 Type 4	5 Type 5
55LA-3253	2	32	530	52	NW	5,994 (s)	5,895 (s)	5,823 (s)	5,588 (s)
75LA-4853	3	48	530	77	NW	8,899 (s)	8,753 (s)	8,646 (s)	8,297 (s)
100LA-6453	4	64	530	103	NW	11,896 (s)	11,700	11,558	11,091
70LA-3270	2	32	700	69	NW	7,385 (s)	7,576 (s)	7,293 (s)	7,068 (s)
105LA-4870	3	48	700	104	NW	10,965 (s)	11,249 (s)	10,828 (s)	10,494 (s)
135LA-6470	4	64	700	139	NW	14,657 (s)	15,037	14,475 (s)	14,028
105LA-321A	2	32	1050	107	NW	10,199 (s)	10,458	10,072 (s)	9,767
160LA-481A	3	48	1050	158	NW	15,144 (s)	15,565	14,955 (s)	14,465
215LA-641A	4	64	1050	211	NW	20,243	20,252	19,991	19,880

- System input wattage may vary based on input voltage, by up to +/- 10% , and based on manufacturer forward voltage, by up to +/- 8%.
 - Lumen values based on photometric tests performed in compliance with IESNA LM-79.
- (s). Data is scaled based on tests of similar, but not identical, luminaires.

Dimensions – Standard EcoForm luminaire

Top View

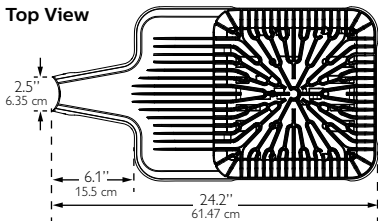

Side View

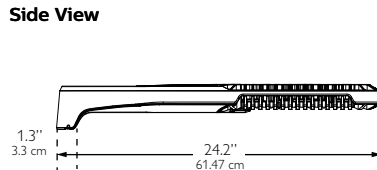

End View

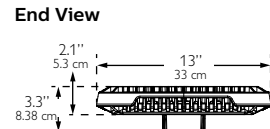

EPA (ft²/m²)

Single	Twin (2@180)	3/4@90
0.2 / 0.019	0.5 / 0.046	0.5 / 0.046

Approximate Luminaire Weight:
20 Lbs (9.07 Kg)

ECF EcoForm

Site & Area

Dimensions – EcoForm with Retrofit Arm Mount (RAM)

Top View

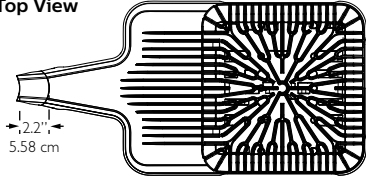

Side View

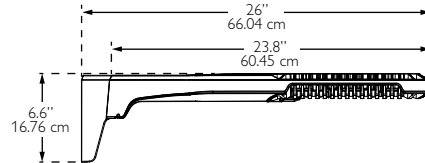

End View

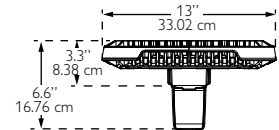

EPA (ft²/m²)

Single	Twin (2@180)	3/4@90
0.3 / 0.028	0.6 / 0.056	0.7 / 0.065

Approximate Luminaire Weight:
21 Lbs (9.53 Kg)

Dimensions – EcoForm with Mast Arm Fitter (MA)

Top View

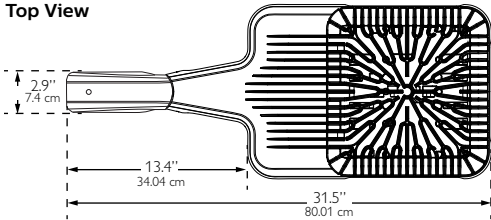

Side View

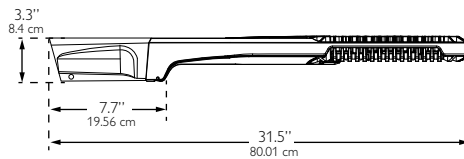

End View

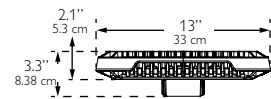

EPA (ft²/m²)

Single
0.51 / 0.047

Approximate Luminaire Weight:
21.5 Lbs (9.77 Kg)

Dimensions – EcoForm with Wall Mount (WS)

Top View

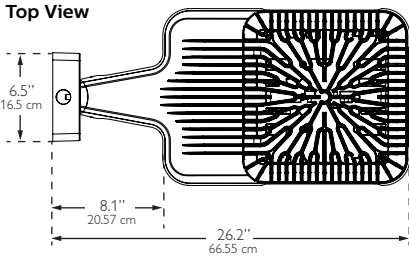

Side View

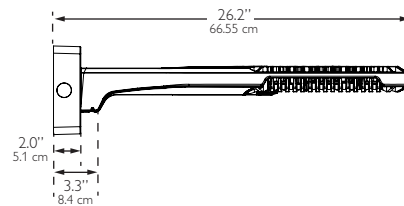

End View

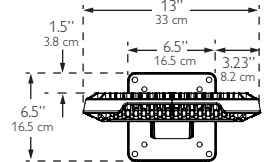

Approximate Luminaire Weight:
23.36 Lbs (10.6 Kg)

Dimensions – EcoForm with LimeLight Luminaire mounted controller

Top View

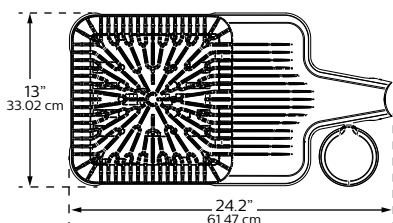

Side View

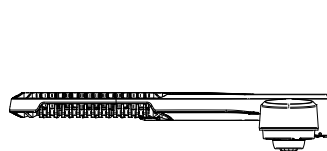

End View

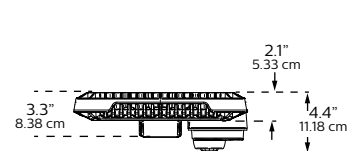

ECF EcoForm

Site & Area

Luminaire Configuration Information

ECF

Philips Gardco EcoForm LED standard luminaire providing constant wattage and constant light output when power to the luminaire is energized.

ECF-DIM

Philips Gardco EcoForm LED luminaire provided with 0-10V dimming for connection to a control system provided by others.

ECF-APD

Philips Gardco EcoForm LED luminaire with Automatic Profile Dimming. Luminaire is provided with a Philips DynaDimmer module, programmed to go to 50% power, 50% light output two (2) hours prior to night time mid-point and remain at 50% for six (6) hours after night time mid-point. Mid-point is continuously recalculated by the Philips DynaDimmer module based on the average mid-point of the last two full night cycles. Short duration cycles, and power interruptions are ignored and do not affect the determination of mid-point.

ECF-APD is available in 120V–277V input only.

ECF-APD Dimming Profile:

100%	2 hours 50%	6 hours 50%	100%
Power On	Mid Point	Power Off	

ECF-MR50

Philips Gardco EcoForm LED luminaire with motion response, providing a 50% power reduction on low and a commensurate reduction in light output. The power and light output reduction is accomplished utilizing the Philips DynaDimmer module, programmed for a constant 50% power. Power supplied by the motion sensor connected to the override line on the DynaDimmer takes the luminaire to high setting, 100% power and light output, when motion is detected. The luminaire remains on high until no motion is detected for the motion sensor duration period, after which the luminaire returns to low. Duration period is factory set at 15 minutes, and is field adjustable from 5 minutes up to 15 minutes.

ECF-MR50 is available in 120V–277V input only to the luminaire. Motion sensors require single voltage 120V or 277V input.

The Area PIR motion sensor is the WattStopper EW-200-120-W (120V Input – MSA-120V) or the WattStopper EW-200-277-W (277V Input – MSA-277V.) One motion sensor per pole is required and is ordered separately. Area sensors require single voltage 120V or 277V input.

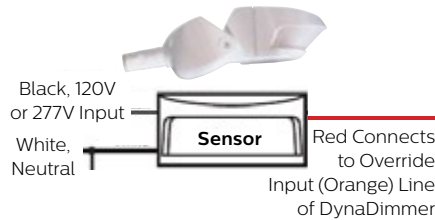

The area motion detector provides coverage equal to up to 6 times the sensor height above ground, 270° from the front-center of the sensor.

Area PIR Motion Sensor Coverage Pattern:

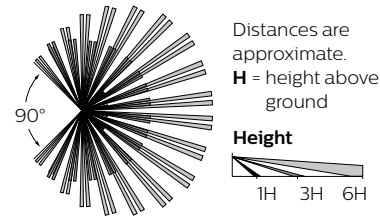

Motion response requires that the pole include an additional hand hole 15 feet above the pole base, normally oriented 180° to the standard hand hole. For Philips Gardco poles, order the pole with the Motion Sensor Mounting (MSM) option which includes the hand hole and a special hand hole cover plate for the sensor with a 1/2" NPT receptacle centered on the hand hole cover plate into which the motion sensor mounts. Once the motion sensor is connected to the hand hole cover plate, then wiring connections are completed in the pole. The plate (complete with motion sensor attached and wired) is then mounted to the hand hole. If poles are supplied by others, the customer is responsible for providing suitable mounting accommodations for the motion sensor in the pole.

Mounting to a Philips Gardco Pole:

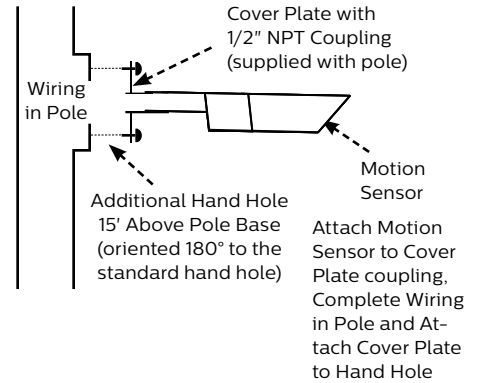

ECF-APD-MRO

Philips Gardco EcoForm LED luminaire with Automatic Profile Dimming, with Motion Response Override. The ECF-APD-MRO combines the benefits of both automatic profile dimming and motion response, using the Philips DynaDimmer module. The luminaire will dim to 50% power, 50% light output, per the dimming profile shown for the ECF-APD. If motion is detected during the time that the luminaire is operating at 50%, the luminaire returns to 100% power and light output. The luminaire remains on high until no motion is detected for the duration period, after which the luminaire returns to low. Duration period is factory set at 15 minutes, and is field adjustable from 5 minutes up to 15 minutes.

Notes:

ECF-APD-MRO is available in 120V through 277V input only to luminaire. The motion sensor requires either 120V or 277V input to the motion sensor.

The ECF-APD-MRO has the same pole requirements and utilizes the same motion sensors as the ECF-MR50. The motion sensor mounts and wires identically as well. The ECF-APD-MRO utilizes the identical dimming profile as shown for the ECF-APD.

By combining the benefits of automatic profile dimming and motion response, the ECF-APD-MRO assures maximum energy savings, and insures that adequate light is present if motion is detected.

All motion sensors utilized consume 0.0 watts in the off state.

ECF EcoForm

Site & Area

Luminaire Configuration Information (Continued)

ECF-MRI

Luminaires with Motion Response include a LED driver and an integral programmable motion sensor. The motion sensor is set to a constant 50%. When motion is detected, the luminaire goes to 100%. The luminaire remains on high until no motion is detected for the motion sensor duration period, after which the luminaire returns to low. Duration period is factory set at 5 minutes. Available with 120V or 277V only.

Luminaires include a passive infrared (PIR) motion sensor, WattStopper® FSP-211 equipped with an FSP-L3 lens, capable of detecting motion within 20 feet of the sensor, 180° around the luminaire, when placed at a 20 foot mounting height, or mounted on a wall. Available in 120V or 277V input only. Motion sensor off state power is 0.0 watts.

The approximate motion sensor coverage pattern is as shown below.

Side Coverage Pattern

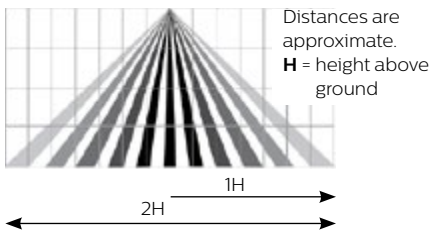

Top Coverage Pattern

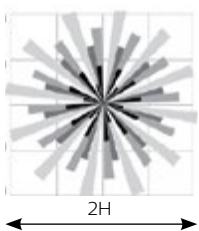

ECF-APD-MRI



Luminaires with Automatic Profile Dimming and Motion Response Override combine the benefits of both automatic profile dimming and motion response. APD-MRI luminaires utilize Philips DynaDimmer. The luminaire will dim to 50% power, 50% light output, per the dimming profile shown for APD luminaires (see page 4). If motion is detected during the time that the luminaire is operating at 50%, the luminaire goes to 100% power and light output. The luminaire remains on high until no motion is detected for the duration period, after which the luminaire returns to low. Duration period is factory set at 5 minutes.

APD-MRI luminaires are available with 120V or 277V input voltages only.

APD-MRI luminaires use the identical motion sensor as MRI luminaires. See motion sensor details for ECF-MRI.

FS1R-100 Wireless Remote Programming Tool

The FS1R-100 Remote Programming Tool accessory permits adjustment of ECF-MRI and ECF-APD-MRI sensor settings, including duration and dimming level on low, without the need to connect any wires to the luminaire.

The FS1R-100 Wireless IR Programming Tool is a handheld tool for setup and testing of WattStopper FSP-211. It provides wireless access to the FSP-211 sensors for setup and parameter changes.

The FS1R-100 display shows menus and prompts to lead you through each process. The navigation pad provides a familiar way to navigate through the customization fields.

Within a certain mounting height of the sensor, the FS1R-100 allows modification of the system without requiring ladders or tools simply with a touch of a few buttons.

The FS1R-100 IR transceiver allows bi-directional communication between the FSP-211 and the FS1R-100 programming tool. Simple menu screens let you see the current status of the system and make changes. It can change FSP-211 sensor parameters such as high/low mode, sensitivity, time delay, cut off and more. With the FS1R-100 you can also establish and store FSP-211 parameter profiles.

The FS1R-100 operates on three standard 1.5V AAA Alkaline batteries or three rechargeable AAA NiMH batteries. The battery status displays in the upper right corner of the display. Three bars next to BAT= indicates a full battery charge. A warning appears on the display when the battery level falls below a minimum acceptable level. To conserve battery power, the FS1R-100 automatically shuts off 10 minutes after the last key press.

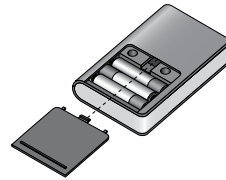

You navigate from one field to another using (up) or (down) arrow keys. The active field is indicated by flashing (alternates between yellow text on black background and black text on yellow background.)

Once active, use the Select button to move to a menu or function within the active field. Value fields are used to adjust parameter settings. They are shown in "less-than/greater-than" symbols: <value>. Once active, change them using (left) and (right) arrow keys. In general the up key increments and the down key decrements a value. Selections wrap-around if you continue to press the key beyond maximum or minimum values. Moving away from the value field overwrites the original value. The Home button takes you to the main menu. The Back button can be thought of as an undo function. It takes you back one screen. Changes that were in process prior to pressing the key are lost. More information on the FS1R-100 Remote Programming Tool is available at wattstopper.com.

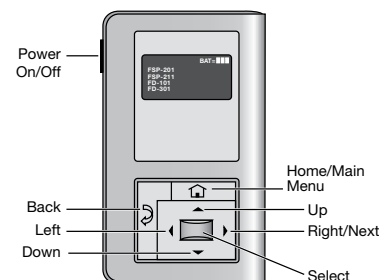

ECF EcoForm

Site & Area

Luminaire Configuration Information – EcoForm with LimeLight

ECF-LLC2

EcoForm with Limelight wireless technology
Controller pod attached to luminaire arm and includes radio, photocell and motion sensor with #2 lens for 8-15' mounting heights.

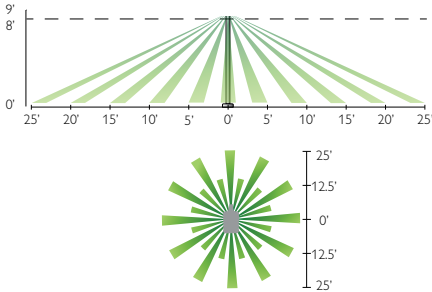

ECF-LLC3

EcoForm with Limelight wireless technology
Controller pod attached to luminaire arm and includes radio, photocell and motion sensor with #3 lens for 15-25' mounting heights.

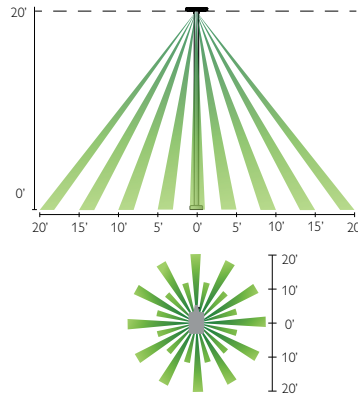

ECF-LLC4

EcoForm with Limelight wireless technology
Controller pod attached to luminaire arm and includes radio, photocell and motion sensor with #4 lens for 25-40' mounting heights.

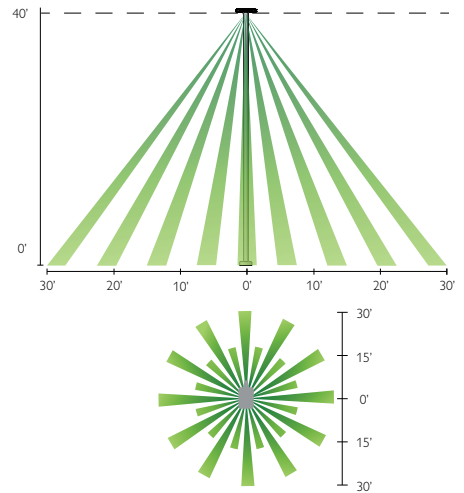

Luminaire Configuration Information – EcoForm with LimeLight

ECF-LLC(#)

With this configuration, the controller pod is mounted to the luminaire arm. One controller is required per luminaire. There are three different motion sensor configurations available. Each one corresponds to the desired mounting height that for your specific application. See motion response detection ranges below.

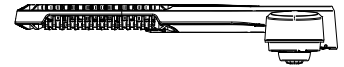
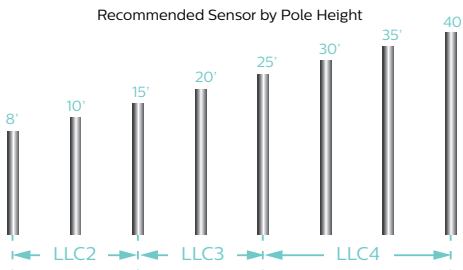

Controller Pod

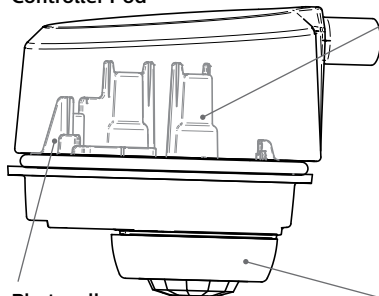

Wireless Radio

- 1.8 Watts max (no load draw)
- Operating voltage 102-277V RMS
- Communicates using the ZigBee protocol
- Carries out dimming commands from gateway
- Reports internal PCB temperature
- Transmission Systems Operating within the band 2400-2483.5Mhz. IEEE 802.15.4
- ROHS Compliant

Photocell

- Ambient light photocell on every wireless radio that averages the light levels of up to 5 controllers for an accurate reading and optimal light harvesting activity.
- Reports ambient light readings to 1500 Fc.

Motion Response

- Three different lens configurations
- Detects motion through passive InfraRed sensing technology
- Connects directly to radio through modular jack
- Three different mounting heights and detection ranges available

ECF EcoForm

Site & Area

Luminaire Configuration Information – EcoForm with LimeLight (Continued)

Gateway

Overview: One gateway is included with the wireless controls system. The gateway opens up communication with the wireless radios installed with the EcoForm luminaires (or pole), allowing you to control your fixtures straight from the web. One LimeLight gateway can communicate with up to 800 fixtures. Typically one unit is required per parking lot.

Installation: Gateway has 4 blind threaded holes on the back side that accept 10-32 screws. Mount spacing is 10.41" across and 14.19" vertical.

Requirements: The gateway must be mounted in a secure on-site location. The gateway requires 120V. Distance of gateway to the first radio varies upon application; contact factory. Strong internet connection required.

Specifications:

- High density RF Mesh coordinator
- Ethernet or wireless internet connection to LimeLight server
- Proprietor of software "rules of operation"
- Watertight Ethernet connections
- Highly protected, long life ac/dc power supply
- Single board, ARM compliant 520Mhz Intel computer.
- Operating Temperature -20°C to 55°C
- Tamper proof housing

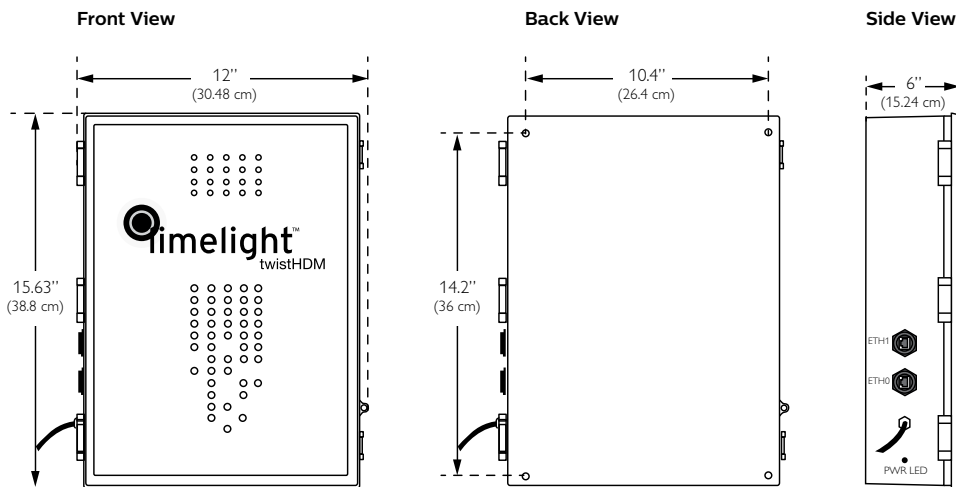
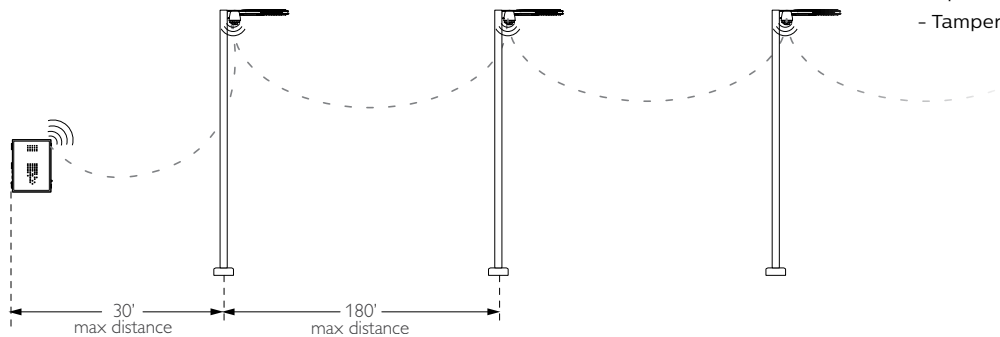

Specifications

Housing

One piece die cast aluminum housing with integral arm and separate, self retained hinged, one piece die cast door frame.

IP Rating

LED light engine rated IP66.

Vibration Resistance

EcoForm with Standard Arm carries a 3G vibration rating that conforms to standards set forth by ANSI C136.31. Testing includes vibration to 3G acceleration in three axes, all performed on the same luminaire.

Electrical

Driver efficiency (>90% standard). 120-480V available (restrictions apply). Open/short circuit protection. Optional 0-10V dimming to 10% power. RoHS compliant. Surge protector standard. 10KA per ANSI/IEEE C62.41.2.

LED Board and Array

32, 48, or 64 LEDs. Color temperatures: 3000K, 4000K, 5700K +/- 250K. Minimum CRI of 70. Aluminum metal clad board. RoHS compliant.

LED Thermal Management

The housing design allows the one piece housing to provide excellent thermal management critical to long LED system life.

Energy Saving Benefits

System efficacy up to 95 lms/W with significant energy savings over Pulse Start Metal Halide luminaires. Optional control options provide added energy savings during unoccupied periods.

LED Performance

Predicted Lumen Depreciation Data¹

Ambient Temperature °C	Driver (mA)	Calculated L ₇₀ Hours ^{1,2}	L ₇₀ Per TM-21 ^{2,3}	Lumen Maintenance % @ 60,000 hours
Up to 40 °C	Up to 1050 mA	> 350,000 hours	> 60,000 hours	97%

1. Predicted performance derived from LED manufacturer's data and engineering design estimates, based on IESNA LM-80 methodology. Actual experience may vary due to field application conditions.
2. L70 is the predicted time when LED performance depreciates to 70% of initial lumen output.
3. Calculated per IESNA TM21-11. Published L70 hours limited to 6 times actual LED test hours.

Wireless Controls

The LimeLight wireless Controls System includes: gateway, controller pod (with wireless radio, motion response, and photocell), and commissioning/training. LimeLight is an intelligent web-based system that operates through a high density mesh (HDM) wireless technology. Wireless radios with motion response and photocell sensors are integrated with PureForm luminaires, and enable the fixtures to communicate via the ZigBee protocol. The gateway is a mini computer that connects to the internet, and is located in a secure location. The central LimeLight database channels communication to and from the gateway, allowing data to be viewed or managed through the web-based graphical user interface (GUI). See pages 8-10 for details and technical information.

Motion Sensors

ECF-MR50, ECF-APD-MRO, ECF-MRI, ECF-APD-MRI luminaires may be specified for additional energy savings during unoccupied periods. See pages 4-6 for complete details.

Optical Systems

Type 2, 3, 4, and 5 distributions available. Internal Shield option mounts to LED optics and is available with Type 2, 3, and 4 distributions to control backlight.

Mounting

Standard luminaire arm mounts to 4" round poles. Square pole adapter included with every luminaire. Round Pole Adapter (RPA) required for 3-3.9" poles.

Retrofit Arm Mount

EcoForm features an innovative retrofit arm kit. When specified with the retrofit arm (RAM) option, EcoForm seamlessly simplifies site conversions to LED by eliminating the need for additional pole drilling on most existing poles. RAM will be boxed separately.

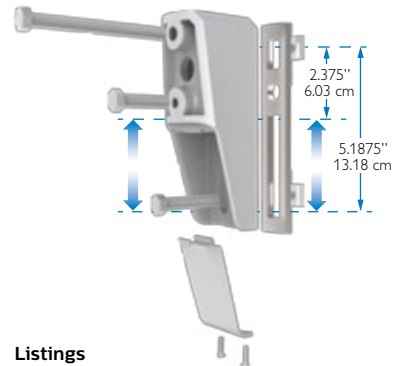

Listings

ETL/cETL listed to the UL 1598 standard, suitable for Wet Locations. Suitable for use in ambients from -40° to 40°C (-40° to 104°F). The quality systems of this facility have been registered by UL to the ISO 9001 series standards. All EcoForm luminaires equipped with NW and CW are DesignLights Consortium® qualified.

Finish

Each standard color luminaire receives a fade and abrasion resistant, electrostatically applied, thermally cured, triglycidyl isocyanurate (TGIC) textured polyester powdercoat finish. Standard colors include bronze (BRP), black (BLP), white (WP), and natural aluminum (NP). Consult factory for specs on optional or custom colors.

Warranty

EcoForm luminaires feature a 5 year limited warranty. Philips Gardco LED luminaires with LED arrays feature a 5 year limited warranty covering the LED arrays. LED Drivers also carry a 5 year limited warranty. Motion sensors are covered by warranty for 5 years by the motion sensor manufacturer.



Job:
Type:
Notes:

TYPE SA
POLE

Poles

Page 1 of 4

4" Straight Square Steel

The Philips Gardco SSS straight steel pole consists of a one-piece square fabricated steel lighting standard. The carbon steel base plate is secured to the shaft with a continuous circumferential weld providing excellent strength and integrity. The poles are finished with an electrostatically applied, thermally cured TGIC polyester powdercoat. All poles include anchor bolts, full base cover, hand hole, ground lug and top cap.



PREFIX	HEIGHT	SIZE	GAUGE	DRILLING	FINISH	OPTIONS
<input type="text"/>	<input type="text"/>	<input type="text"/>	<input type="text"/>	<input type="text"/>	<input type="text"/>	<input type="text"/>

Enter the order code into the appropriate box above. Note: Philips Gardco reserves the right to refuse a configuration. Not all combinations and configurations are valid. Refer to notes below for exclusions and limitations. For questions or concerns, please consult the factory.

PREFIX	HEIGHT	SIZE	GAUGE	DRILLING
SSS4	10'	4"	7	D1 1 Way
	12'			D2 2 Way
	14'		D2@90 2 Way at 90°	
	15'		D3 3 Way	
	18'		D4 4 Way	
	20'		T2 2 3/8" OD Tenon	
	24'		T4 4" OD Tenon	
	25'			
	30'			

FINISH

PP	Prime Painted
BRP	Bronze Paint
BLP	Black Paint
WP	White Paint
NP	Natural Aluminum Paint
GV	Galvanized (No Paint)
FPGV	Finished Paint over Galvanized (specify color)
OC	Optional Color Paint Specify RAL designation ex: OC-RAL7024.
SC	Special Color Paint Specify. Must supply color chip.

OPTIONS

FES	Festoon Outlet
AHH	Additional Hand Hole

For Festoon Outlets and Additional Hand Holes, indicate height above base and orientation to original hand hole. See Pole Orientation Information on Page 4.

Couplings

Indicate size (1/2", 3/4", 1", 1 1/4", 1 1/2".) Indicate height above base and orientation to hand hole. See Pole Orientation Information on Page 4.

CL	Coupling - Internal thread
-----------	----------------------------

Single Mount Bullhorn Brackets

Indicate height above base and orientation to hand hole. See Pole Orientation Information on Page 4.

GM-080-19	Single - 1.9" OD
GM-080-24	Single - 2.4" OD

Motion Response Provisions

GMR	Provision for Gardco HID Motion Response System
------------	---

Minimum Pole Height is 18'. Includes a 1/2" coupling placed 180° to the hand hole, 12' above the pole base.

MSM	Motion Sensor Mounting Provision for LED Luminaires available with Motion Response
------------	--

Minimum Pole Height is 18'. Includes a special hand hole with 1/2" coupling placed in the cover plate, 180° to the hand hole, 15' above the pole base.

Refer to Steel Pole Accessories sheet 79415-26 for additional accessories.

1611 Clovis Barker Road, San Marcos, TX 78666

(800) 227-0758 (512) 753-1000 FAX: (512) 753-7855 sitelighting.com

© 2011 Koninklijke Philips Electronics N.V. All Rights Reserved.

Philips Gardco reserves the right to change materials or modify the design of its product without notification as part of the company's continuing product improvement program.

79415-17/0611

PHILIPS



POLE DATA

CATALOG NUMBER		POLE SIZE		MAXIMUM LUMINAIRE LOADING ¹									ANCHOR BOLT DATA ²		
				HIGH WIND CONDITIONS						NORMAL WIND CONDITIONS					
				130 MPH		120 MPH		110 MPH		100 MPH	90 MPH	80 MPH			
PREFIX	HEIGHT (FT.)	POLE SIZE (inches)	GAUGE	EPA FT ²	Max Weight (lbs)	EPA FT ²	Max Weight (lbs)	EPA FT ²	Max Weight (lbs)	EPA FT ²	EPA FT ²	EPA FT ²	BOLT CIRCLE (inches)	BOLT SIZE (inches)	MAX PROJ. (inches)
SSS	10	4	11	9.9	248	12.0	300	14.5	363	18.9	23.9	30.6	8.0"	3/4 x 17 x 3	4.0"
SSS	12	4	11	7.4	185	9.2	230	11.3	283	14.8	18.8	24.4	8.0"	3/4 x 17 x 3	4.0"
SSS	14	4	11	5.5	138	7.0	175	8.8	220	11.7	15.1	19.9	8.0"	3/4 x 17 x 3	4.0"
SSS	15	4	11	3.8	95	5.0	125	6.7	168	8.9	11.8	15.9	8.0"	3/4 x 17 x 3	4.0"
SSS	18	4	11	2.3	58	3.5	88	4.8	120	6.7	9.2	12.6	8.0"	3/4 x 17 x 3	4.0"
SSS	20	4	11	-	-	1.9	48	3.3	83	4.5	6.7	9.6	8.0"	3/4 x 17 x 3	4.0"
SSS	20	4	7	4.3	108	5.6	140	7.4	185	8.8	11.8	16.0	8.0"	3/4 x 17 x 3	4.0"
SSS	25	4	11	-	-	-	-	-	-	1.0	2.6	4.8	8.0"	3/4 x 17 x 3	4.0"
SSS	25	4	7	1.6	40	2.6	65	3.8	95	5.4	7.7	10.8	8.0"	3/4 x 17 x 3	4.0"
SSS	30	4	7	-	-	-	-	1.2	50	2.6	4.4	6.7	8.0"	3/4 x 17 x 3	4.0"

- Warning:** Additional wind loading, in terms of EPA, from banners, cameras, floodlights and other accessories attached to the pole, must be added to the luminaire(s) EPA before selecting the pole with the appropriate wind load capability.
- Factory supplied template must be used when setting anchor bolts. Philips Gardco will not honor any claim for incorrect anchorage placement resulting from failure to use factory supplied templates.

DIMENSIONS

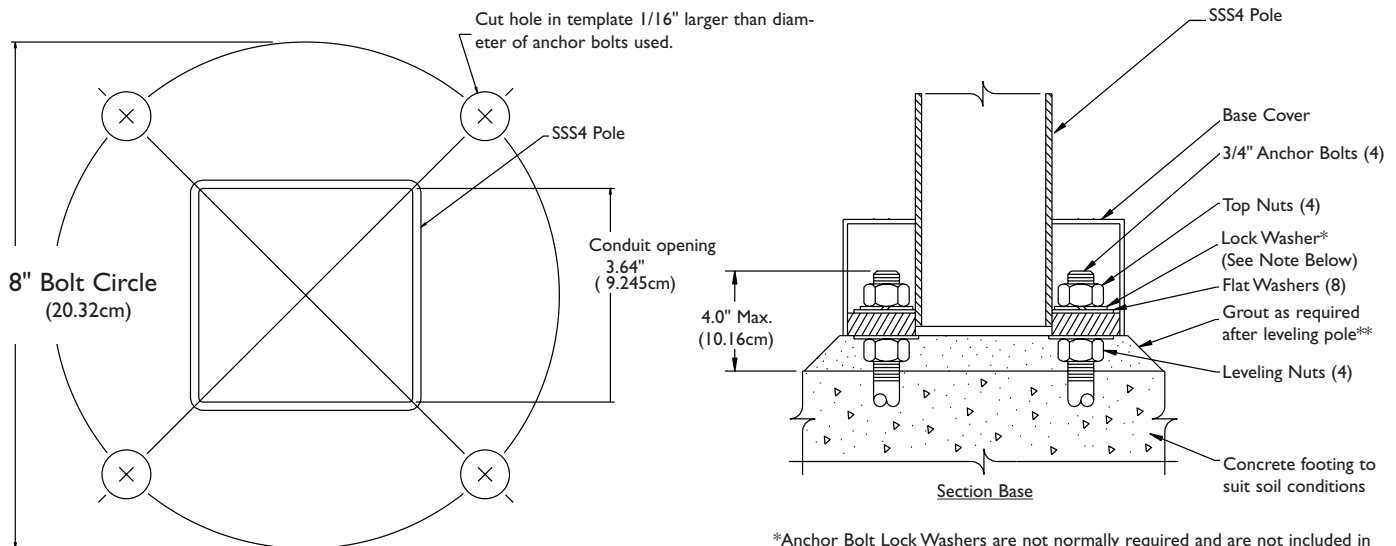

NOTE: Factory supplied template must be used when setting anchor bolts. Philips Gardco will not honor any claim for incorrect anchorage placement from failure to use factory supplied templates.

*Anchor Bolt Lock Washers are not normally required and are not included in standard anchor bolt sets. They are available upon request at additional cost.
 ** Grouting should include a drainage slot or tube (by others) to permit water to drain from the base of the pole. Failure to provide drainage may weaken the pole base structure over time and may result in pole base failure, for which Philips Gardco is not responsible.

SPECIFICATIONS

POLE SHAFT: The pole shaft is fabricated from a single-piece of 11 ga (.1196") or 7 ga (.1793") commercial carbon steel. The formed steel plate is longitudinally welded providing minimum yield strength of 46 KSI.

ANCHOR BASE: The pole anchor base is fabricated from A-36 structural quality carbon steel with a minimum yield strength of 36 KSI. The base plate telescopes the pole shaft and is circumferentially welded on both top and bottom.

ANCHOR BOLTS: Anchor bolts are fabricated from a commercial quality hot rolled carbon steel bar that meets or exceeds a minimum guaranteed yield strength of 50,000 psi. Bolts have an "L" bend on one end and threaded on the opposite end. Anchor bolts are galvanized a minimum of 12" on the threaded end. Four (4) properly sized bolts, each furnished with two (2) regular hex nuts and two (2) flat washers, are provided per pole, unless otherwise specified.

BASE COVER: A two-piece base cover completely conceals the entire base plate and anchorage.

HAND HOLE: The reinforced hand hole has a nominal rectangular 2" X 4" inside opening in the pole shaft. Included is a cover plate with attachment screws. The hand hole is located 18" above the base and 180° clockwise with respect to the luminaire arm when viewed from the top of the pole for one arm. For two arms the hand hole is located directly under one arm.

POLE TOP CAP: Each pole assembly is provided with a removable pole top cap.

FINISH: Poles are available with a bronze, natural, white or black electrostatically applied, thermally cured TGIC polyester powdercoat finish.

STOCK POLES: Poles provided from stock under the Quick Ship program are drilled for four (4) luminaires at 90° with three (3) hole sets plugged.

GENERAL POLE INFORMATION

DESIGN: The poles as charted are designed to withstand dead loads and predicted dynamic loads developed by variable wind speeds with an additional 30% gust factor under the following conditions:

The charted weights include luminaire(s) and/or mounting bracket(s).

The wind velocities are based on 10 mph increments from 80 mph through 100 mph. Poles to be located in areas of known abnormal conditions may require special consideration. For example: coastal areas, airports and areas of special winds.

Poles are designed for ground mounted applications. Poles mounted on structures (such as buildings and bridges) may also necessitate special consideration requiring Philips Gardco's recommendation.

Height correction factors and drag coefficients are applied to the entire structure. An appropriate safety factor is maintained based on the minimum yield strength of the material incorporated in the pole.

WARNING: This design information is intended as a general guideline only. The customer is solely responsible for proper selection of pole, luminaire, accessory and foundation under the given site conditions and intended usage. The addition of any items to the pole, in addition to the luminaire, will dramatically impact the EPA load on that pole. It is strongly recommended that a qualified professional be consulted to analyze the loads given the user's specific needs to ensure proper selection of the pole, luminaire, accessories, and foundation. Philips Gardco assumes no responsibility for such proper analysis or product selections. **Failure to insure proper site analysis, pole selection, loads and installation can result in pole failure, leading to serious injury or property damage.**

GENERAL INFORMATION: Mounting height is the vertical distance from the base of the lighting pole to the center of the luminaire arm at the point of luminaire attachment. Twin arms as charted are oriented at 180° with respect to each other. For applications of two (2) arms at 90° or other multiple arm applications, consult the factory.

WARRANTY: Philips Gardco poles feature a 1 year limited warranty. See Warranty Information on www.sitelighting.com for complete details and exclusions.

ORIENTATION INFORMATION

FACTORY INSTALLED OPTIONS AND ACCESSORIES

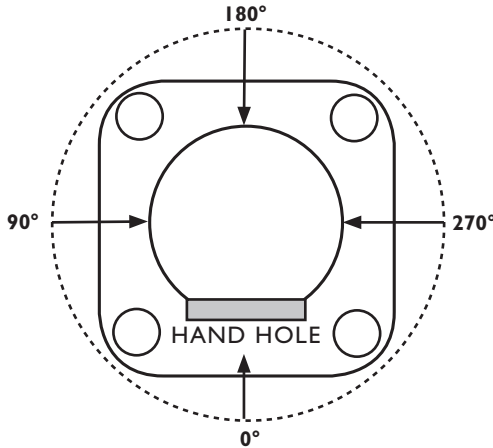

Orientation is measured clockwise from the Hand Hole Center.

For Factory Installed Options and Accessories, Specify Orientation from Hand Hole and Height Above Pole Base Where Required.

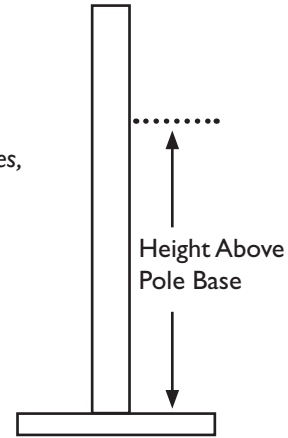

STANDARD ARM MOUNT LUMINAIRE ORIENTATION

D1 Drilled for Single Luminaire

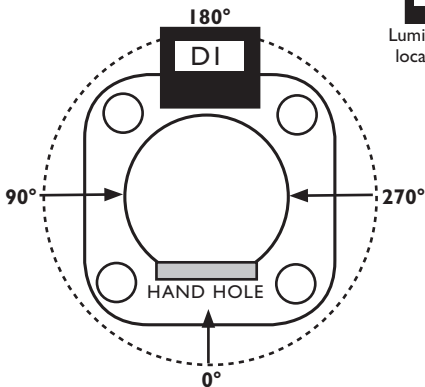

D2 Drilled for 2 Luminaires at 180°

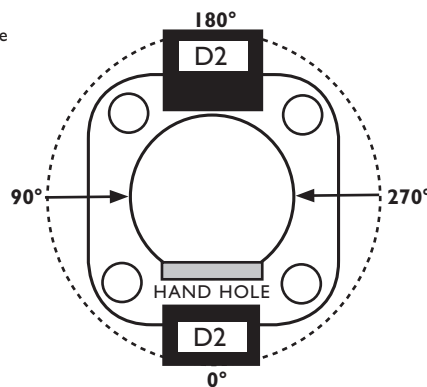

D3 Drilled for 3 Luminaires @ 90°

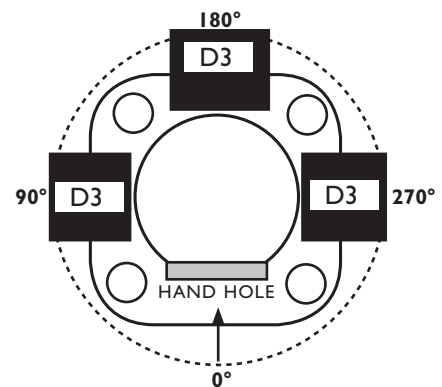

D4 Drilled for 4 Luminaires at 90°

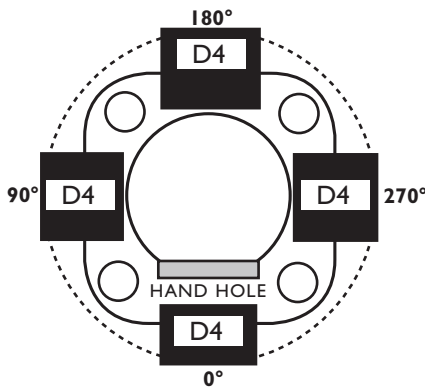

D2@90 Drilled for 2 Luminaires at 90°

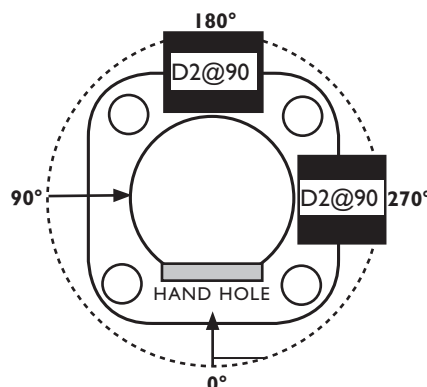

High performance and integrated style, all in one luminaire

LED Wall Sconce 161

TYPE SB

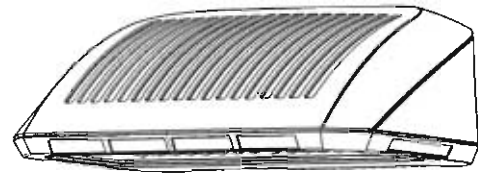

DESIGNLIGHTS CONSORTIUM 

Project: _____
 Location: _____
 Catalog No: _____
 Fixture Type: _____
 Mfg: _____ Qty: _____
 Notes: _____

PHILIPS GARDCO, LED WALL SCONCE 161

The Philips Gardco LED Wall Sconce 161 is an enlarged and enhanced version of the 121, providing performance capability up to that of a 400W metal halide luminaire, while using considerably less energy.

Ordering guide

example: 161-CWL-2-70LA-6435-CW-UNIV-BRP

Prefix		Distribution	Wattage	LED Type	Voltage	Finish	Options
161-CWL	Sconce 161 LED	2 IES Type 2 distribution	350mA	CW	5700°K	BRP	F ²
161-MR	161 with motion response (120V or 277V only)	3 IES Type 3 distribution	70LA-6435 2 LED arrays, 70W	NW	4000°K	BLP	PCB ¹
161-DCC ¹	161 with dual circuit control	4 IES Type 4 distribution	110LA-9635 2 LED arrays, 110W	WW	3000°K	NP	DL
161-DIM	161 with 0-10V dimming controlled by others		530mA			WP	WS
161-APD	161 with automatic profile dimming (120V thru 277V ONLY)		110LA-6453 2 LED arrays, 110W		UNIV	OC	
161-APD-MRI	161 with automatic profile dimming and motion response override – integrated motion sensor (120V or 277V ONLY)		170LA-9653 2 LED arrays, 170W		HVU	SC	
			700mA				
			150LA-6470 2 LED arrays, 150W				
			220LA-9670 2 LED arrays, 220W				

Footnotes:

¹ For luminaires with input voltages above 277V (347, 480 or HVU) the 161-DCC is available with 110LA-9635, 170LA-9653 and 220LA-9670 LED wattages only.

² Available 120-277V only. Provide specific input voltage.

Accessories (order separately)

- **FS1R-100** – MR hand held programmer (For use with 'MR' motion response when field programming is required). If desired, only one is needed per job.

Features

- Complements the 121 wall sconce
- Perfect companion to Philips Gardco PureForm site and area luminaires
- Type 2, 3, and 4 optical distributions available
- Full cutoff performance minimizes glare and light trespass
- 10kA surge protection provided standard, meeting ANSI C62.41.2

Benefits

- Exceptional performance can reduce pole requirements on a site
- Motion response and control options available for additional energy savings
- Performance equivalent to 400W HID while utilizing less energy

Description

- **Housing:** Die cast housing
- **Finish:** Painted finish only
- **Lens:** Light engines will be sealed IP66 (in downlight application only). Tempered flat glass and diffuse glass lens option
- **Mounting:** Wall mounted only
- **Supply connection:** 90°C supply wire minimum (supplied by others)
- **Driver:** 120-277VAC and 347-480VAC non-class 2, constant current driver 350mA and 530mA, 700mA 0-10VDC dimming
- **Light engine:** LEDgine 32, 48 LEDs. LEDgine optics - acrylic. IES distributions - 2, 3, and 4, 0% uplight (full cut-off).
- **Agency approvals:** UL/CUL listed for wet locations when mounted in the downlight position. All 161 luminaires equipped with NW or CW are DesignLights Consortium[®] qualified.



LED Wattage and Lumen Values

Ordering Code	Average System Watts ¹	LED Current (mA)	LED Quantity - Dual LED Arrays		LED Selection	Luminaire Initial Absolute Lumens		
			Per LED Array	Total LEDs		TYPE 2	TYPE 3	TYPE 4
70LA-6435	74.4	350	32	64	NW	6,815	7,105	6,890
110LA-9635	110.0	350	48	96	NW	10,029	10,469	10,171
110LA-6453	106.8	530	32	64	NW	9,565	9,972	9,670
170LA-9653	158.0	530	48	96	NW	14,061	14,532	14,181
150LA-6470	142.0	700	32	64	NW	11,957	12,466	12,087
220LA-9670	210.0	700	48	96	NW	17,509	18,103	17,822

Dimensions

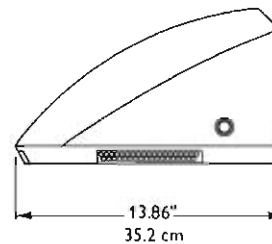
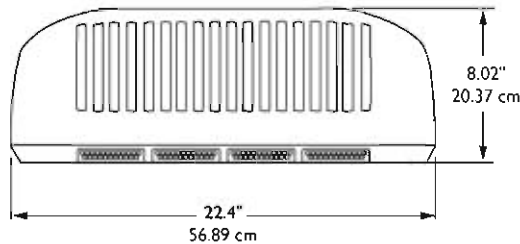

Approximate luminaire weight – 40lbs (18.15kg)

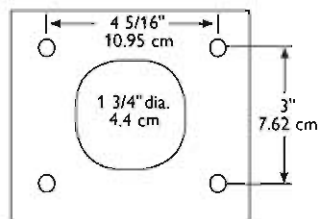

Mounting plate and bolt pattern

Note: Mounting plate center is located in the center of the luminaire width and 3.5" (8.89cm) above the luminaire bottom (lens down position). Splices must be made in the J-box (by others). Mounting plate must be secured by max. 5/16" (.79cm) diameter bolts (by others) structurally to the wall.

Distribution Options

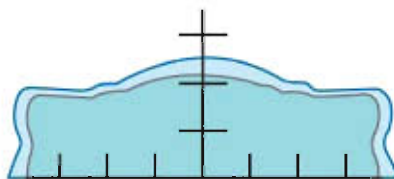

Type 2

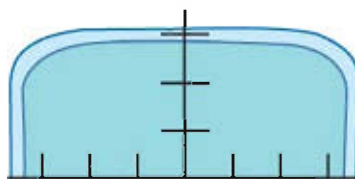

Type 3

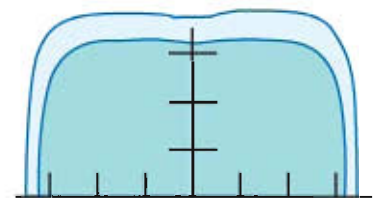

Type 4

LED Performance

Predicted Lumen Depreciation Data ¹		
Ambient Temperature °C	Driver mA	L ₇₀ Hours ²
25 °C	350 mA	180,000
	530 mA	150,000
	700 mA	120,000
40 °C	350 mA	170,000
	530 mA	130,000
	700 mA	100,000

Footnotes:

- Wattage may vary by +/- 8% due to LED manufacturer forward volt specification and ambient temperature. Wattage shown is average for 120V through 277V input. Actual wattage may vary by an additional +/- 10% due to actual input voltage.
- Predicted performance derived from LED manufacturer's data and engineering design estimates.
- L₇₀ is the predicted time when LED performance depreciates to 70% of initial lumen output.

Luminaire Configuration Information

- **161-CWL:** 161 LED sconce providing constant wattage and constant light output when power to the luminaire is energized.
- **161-MR:** Luminaires include a passive infrared (PIR) motion sensor. WattStopper[®] FSP-211 equipped with an FS-L3W lens, capable of detecting motion within 20 feet of the sensor, 180° around the luminaire, when placed at a 20 foot mounting height, and mounted on a wall. Available in 120V or 277V input only. Motion sensor off state power is 0.0 watts.

In Motion Response (MR) luminaires, when no motion is detected for 10 minutes, the Motion Response system reduces the wattage by 90%, to 10% of the normal constant wattage, reducing the light level accordingly. When motion is detected by the PIR, the luminaire returns to full wattage and full light output. Dimming on low is factory set to 10% with duration set at 10 minutes.

The approximate motion sensor coverage pattern is as shown below.

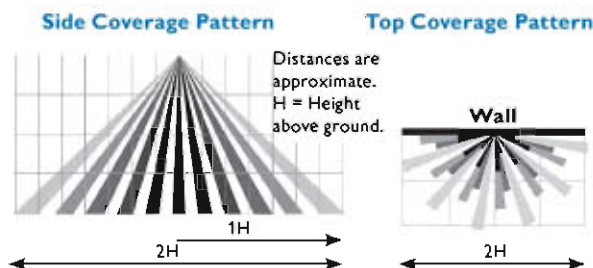

- **FS1R-100 Wireless Remote Programming Tool:** The FS1R-100 Remote Programming Tool accessory permits adjustment of 161-MR sensor settings, including duration and dimming level on low, without the need to connect any wires to the luminaire.

The FS1R-100 Wireless IR Programming Tool is a handheld tool for setup and testing of WattStopper FSP-211. It provides wireless access to the FSP-211 sensors for setup and parameter changes.

The FS1R-100 display shows menus and prompts to lead you through each process. The navigation pad provides a familiar way to navigate through the customization fields.

Within a certain mounting height of the sensor, the FS1R-100 allows modification of the system without requiring ladders or tools simply with a touch of a few buttons.

The FS1R-100 IR transceiver allows bi-directional communication between the FSP-211 and the FS1R-100 programming tool. Simple menu screens let you see the current status of the system and make changes. It can change FSP-211 sensor parameters such as high/low mode, sensitivity, time delay, cut off and more. With the FS1R-100 you can also establish and store FSP-211 parameter profiles.

The FS1R-100 operates on three standard 1.5V AAA Alkaline batteries or three rechargeable AAA NiMH batteries. The battery status displays in the upper right corner of the display. Three bars next to BAT= indicates a full battery charge. A warning appears on the display when the battery level falls below a minimum acceptable level. To conserve battery power, the FS1R-100 automatically shuts off 10 minutes after the last key press.



You navigate from one field to another using (up) or (down) arrow keys. The active field is indicated by flashing (alternates between yellow text on black background and black text on yellow background.)

Once active, use the Select button to move to a menu or function within the active field. Value fields are used to adjust parameter settings. They are shown in "less-than greater-than" symbols: <value>. Once active, change them using (left) and (right) arrow keys. In general the up key increments and the down key decrements a value. Selections wrap-around if you continue to press the key beyond maximum or minimum values. Moving away from the value field overwrites the original value. The Home button takes you to the main menu. The Back button can be thought of as an undo function. It takes you back one screen. Changes that were in process prior to pressing the key are lost.

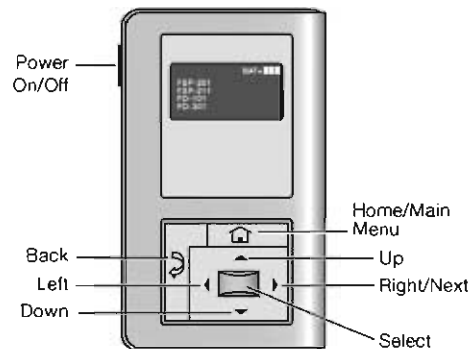

More information on the FS1R-100 Remote Programming Tool is available at wattstopper.com.

The FS1R-100 Wireless Remote Programming Tool can be used to adjust sensor settings on 161-MR luminaires ONLY. It cannot be used to adjust sensor settings on the 161-APD-MRI.

- **161-DCC:** 161 LED sconce provided with dual circuiting, permitting separate switching of each LED array. Note, for luminaires with input voltages above 277V (347, 480 or HVU) the 161-DCC is available with 110LA-963S, 170LA-9653 and 220LA-9670 LED wattages only.
- **161-DIM:** 161 LED sconce provided with 0-10V dimming for connection to a control system provided by others.
- **161-APD:** 161 LED sconces with Automatic Profile Dimming, are provided with a programmable driver, programmed to go to 50% power, 50% light output two (2) hours prior to night time mid-point and remain at 50% for six (6) hours after night time mid-point. Mid-point is continuously recalculated by the programmable driver based on the average mid-point of the last two full night cycles. Short duration cycles, and power interruptions are ignored and do not affect the determination of mid-point.

161-APD is available in 120V through 277V input only.

APD Dimming Profile:

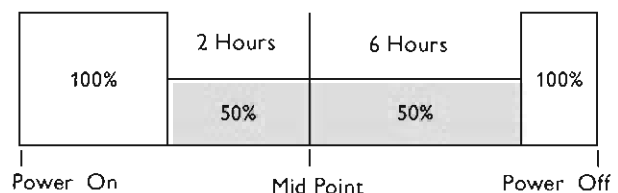

Luminaire Configuration Information

- **161 - APD- MRI:** 161 wall sconce with Automatic Profile Dimming and Motion Response Override (with integral motion sensor) combines the benefits of both automatic profile dimming and motion response. The luminaire will dim to 50% power, 50% light output, per the dimming profile shown for the 161-APD. If motion is detected during the time that the luminaire is operating at 50%, the luminaire returns to 100% power and light output. The luminaire remains on high until no motion is detected for the duration period, after which the luminaire returns to low. Duration period is factory set at 10 minutes.

APD-MRI luminaires are available with 120V or 277V input voltages only.

APD-MRI luminaires use the identical motion sensor as MR luminaires.

Additional Specifications

General Description

The Philips Gardco LED Wall Sconce 161 is an enlarged and enhanced version of the 121, providing performance capability up to that of a 400W metal halide luminaire, while using considerably less energy.

Housing

Housing constructed of die-cast aluminum.

IP Rating

LED light engine rated IP66 (in downlight application only).

Optical Systems

IES Type 2, 3 and 4 distributions available. 0% uplight (full cut-off).

Listings

UL/CUL listed for wet locations when mounted in the downlight position. All 161 luminaires equipped with NVV or CW are DesignLights Consortium® qualified.

Finish

Each luminaire receives a fade and abrasion resistant, electrostatically applied, thermally cured, triglycidal isocyanurate (TGIC) textured polyester powdercoat finish. Standard colors are as listed. Consult factory for specs on custom colors.

Warranty

161 Luminaires feature a 5 year limited warranty. LED luminaires with LED arrays feature a 5 year limited warranty covering the LED arrays. LED drivers are covered by a 5 year limited warranty. PIR sensors carry a 5 year limited warranty from the sensor manufacturer.



PHILIPS
Stonco

Wall mount

LytePro LED Sconce

LPW7



Project: _____

Location: _____

Cat.No: _____

Type: _____

Quantity: _____

Notes: _____

The Philips Stonco LytePro LED Small Wall Sconce LPW7 features outstanding value in a compact, architectural design. This wall sconce offers chip-on-board (COB) LED technology for outstanding energy savings with good photometric performance. LPW7 is ideal for entryways, corridors, facade and other wall/surface lighting applications.

Stocked luminaires – Ordering guide¹

Catalog Number	Description	Master Pack, Qty	UPC Code
LPW7-8BZ	LPW7, 14W COB LED, 350mA, 4000K, 120-277V, Bronze textured paint	6	786034960441
LPW7-8DGY	LPW7, 14W COB LED, 350mA, 4000K, 120-277V, Dark gray textured paint	6	786034960458
LPW7-1BZPCB	LPW7, 14W COB LED, 350mA, 4000K, 120V, Bronze textured paint, w/button photocell	6	786034960472

Stocked accessories – Ordering guide (Must be ordered separately)

Catalog Number	Description	Master Pack, Qty	UPC Code
LPWCVRPLT-BZ	LPW Universal wall cover mounting plate, Bronze textured paint	(none)	786034960618

Description of catalog codes

Family	Drive current	Voltage	Finish	Options
LPW7 = LytePro 7 LED Small Wall Sconce	(Blank - standard 350mA drive current)	8 = 120-277V 1 = 120V	BZ = Bronze textured paint DGY = Dark gray textured paint	PCB = Button photocontrol

1. Color availability and options vary by model; consult stock luminaires ordering guide above.

LPW7 LytePro LED Small Wall Sconce

Features

- LPW7 wall sconce delivers 1,154 lumens at 14W, with an efficacy of 82 lumens per watt.
- 14W LED may effectively replace 60-200W incandescent, 26-42W compact fluorescent and 35-39W HID luminaires.²
- 4000K neutral white at 70 CRI (minimum) is standard.
- Offers two in-stock colors on standard units.*
- 5-year limited warranty; see philips.com/warranties for specific details.

Performance/Specifications

Distribution	Type 2
Initial Lumens (4000K)*	1,154
Average Wattage*	14
Lumens/Watt	82
BUG Rating*	B1/U0/G1
Luminaire Weight	~4lbs (1.8Kg)

Ratings/Approbations/Certifications

Ingress Protection	IP65 Optical
DLC Listed	DLC QPL
cETLus	Certified for use in wet locations
Rated Ambient Temperature	-30°C (-22°F) to 40°C (104°F)

Fixture Dimensions³

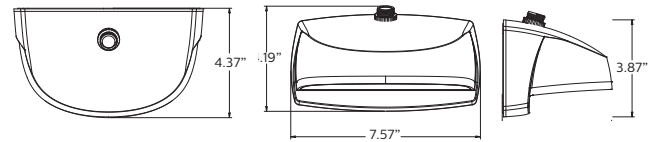

Accessory Dimensions (ordered separately)

LPWCVRPLT-BZ LPW Universal wall cover mounting plate, 0.08" aluminum, bronze textured paint (used to cover larger pre-existing opening or surfaces, field installed). Offers same J-Box pattern as luminaire or may lagged to wall using (4) knockouts.

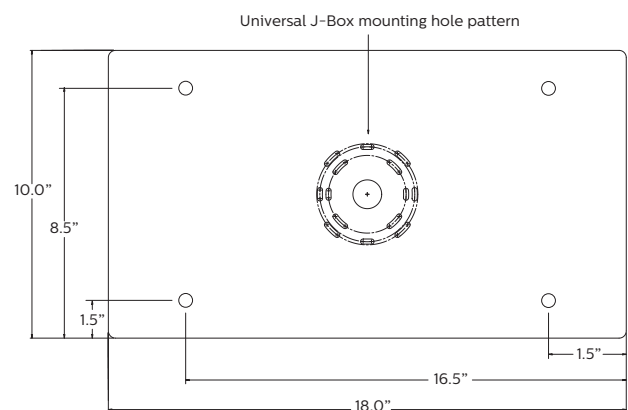

2. Comparable equivalency to HID and other lamp sources depends on multiple criteria including mounting height, fixture spacing, efficiency, performance and classification of the luminaire being replaced and application lighting criteria required for the given project.
3. PCB shown for placement only, available on specific models only (see ordering guide).

Distribution Pattern

LPW7 - 8' MOUNTING HEIGHT

MOUNTING HEIGHT	6'	8'	10'
MULTIPLIER	1.78	1.0	0.64

- 4. Isolines shown at 2.0, 1.0, 0.5, & 0.2 FC.
- 5. Choose mounting height. Use MULTIPLIER (X) EXISTING FC VALUE = NEW FC VALUE.
- 6. FC values are based on initial lumen output.
- 7. Gridline spacing is in units of chosen mounting height.

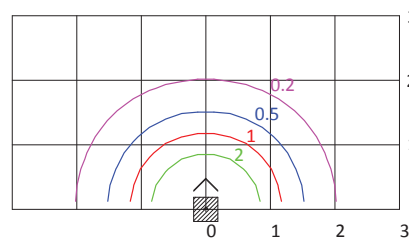

LPW7 LytePro LED Small Wall Sconce

General Description

The Philips Stonco LytePro LED Small Wall Sconce LPW7 combines excellent performance, design and value to meet the needs of the energy and budget conscious. The LPW7 is available for use in downward facing, surface wall mount applications, over recessed j-boxes or where power can be directly fed through back surface, whereby connections splices can be made inside the luminaire housing. Three SKU's are available as in-stock configurations (2-day quick ship). Two standard finishes. 120V button photocell is available in bronze only.

Housing

Die-cast housing houses both the LED and driver assemblies. Design incorporates an integrated heat sink to maximize thermal performance and reliability. Backplate is corrosion free, composite polycarbonate, with built-in level bubble, offers integral interlocking hook and mount design for easy installation.

Mounting

Easy interlocking hook and mount housing/backplate design for easy installation. Mounts over 3.5", 4" octagonal j-boxes and single gang switch boxes (mounted horizontally) or can be directly lagged to surface. Ensure proper steps for gasket/sealing luminaire to surface.

IP Rating

Optical compartment is IP65 rated.

LED Board and Array

Provides up to 82 lm/W at the system level. Standard color temp is 4000K +/- 250K, minimum 70 CRI.

Electrical

Driver efficiency (>90% standard). 120-277V. Temp range: -30°C (-22°F) to 40°C (104°F). Open/short circuit protection. RoHS compliant.

Listings

Product is cETLus listed suitable for Wet Locations. Suitable for use in ambients from -30°C to 40°C (-22°F to 104°F). DesignLights Consortium® qualified. Stocked SKUs of the LPW family are made in China.

Finish

Each luminaire receives a fade and abrasion resistant, electrostatically applied, thermally cured, triglycidal isocyanurate (TGIC) textured polyester powdercoat finish. Two standard colors are available: Dark Grey, and Bronze. Specific options are only available in bronze.

Warranty

LPW7 luminaires, the LED arrays, and the drivers are all covered by a 5-year limited warranty. See philips.com/warranties for details.

LED Performance:

PREDICTED LUMEN DEPRECIATION DATA^{4,6}

Ambient Temp. °C	Calculated L70 hrs ⁵	Reported L70 Per TM-21 ^{5,6}	Calculated Lumen Maint. % @60,000 hrs
up to 40°C	>200,000 hrs	>36,000 hrs	97%

4. Calculated performance derived from LED manufacturer's data and engineering design estimates, based on IESNA LM-80 methodology. Actual experience may vary due to field application conditions.

5. L70 is the predicted time when LED performance depreciates to 70% of initial lumen output.

6. Reported per IESNA TM21-11. Published L70 hours limited to 6 times actual LED test hours.



© 2014 Koninklijke Philips N.V. All rights reserved. Philips reserves the right to make changes in specifications and/or to discontinue any product at any time without notice or obligation and will not be liable for any consequences resulting from the use of this publication. philips.com/luminaires



Philips Lighting North America Corporation
200 Franklin Square Drive, Somerset, NJ 08873
Tel. 855-486-2216

Imported by: Philips Lighting,
A division of Philips Electronics Ltd.
281 Hillmount Rd, Markham, ON, Canada L6C 2S3
Tel. 800-668-9008

UCM/UCL

Universe Collection® – Medium/Large Scale

STREET LIGHT

CONTEMPORARY



- MicroCore™ technology
- First decorative, modular system with precise LED aiming capabilities
- Surge protection included
- 0-10v dimming ready
- IP66 optics
- DLC listed
- Powder coat finish in 13 standard colors with a polymer primer sealer

ORDERING INFORMATION

UCM/UCL		HOOD		COLOR TEMPERATURE		COLORS		OPTIONS	
UCM	Universe Medium	ANG	Angled hood	UCM		AWT	Arctic White	OPTIONS - HOOD	
UCL	Universe Large	BEL	Bell hood	32LED-3K	Warm White, 3000K output	BLK	Black	COP	Copper
UCM Upgrade Kit – UCM-LK		FLR	Flared hood	32LED-4K	Neutral White, 4200K output	MTB	Matte Black	STS	Stainless Steel
UPLT	For internal illumination. Add 4 watts	STR	Straight hood	32LED-5K	Bright White, 5100K output	DGN	Dark Green	OPTIONS	
Distribution	T2, T3, T4, T5, TL, TR	SKB	Skirted bell hood	UCL		DBZ	Dark Bronze	WIH	Integral HBA wiHUBB IFM transceiver and antenna
Color	32LED-3K, 32LED-4K, 32LED-5K	LUMINOUS ELEMENTS		56LED-3K	Warm White, 3000K output	WRZ	Weathered Bronze	SLC	Luminous element remains unlit during normal operation
Driver	700 (700mA, 75 watts)	WND	4 luminous windows	56LED-4K	Neutral White, 4200K output	BRM	Metallic Bronze	FTG	Flat glass lens.
Bezel Fishes	Available in 13 standard finishes and premium finishes	SR	Solid rings	56LED-5K	Bright White, 5100K output	VBL	Verde Blue	FLD	Lightly diffused finish on flat glass lens
UCL Upgrade Kit – UCL-LK		VSL	Vertical slots	DRIVER		CRT	Corten	SAG	Clear sag glass lens. UCM MicroCore only.
UPLT	For internal illumination. Add 4 watts	LUM	Luminous rings	120 thru 277 volt		MAL	Matte Aluminum	RCK	Rock guard painted black. UCM only.
Distribution	T2, T3, T4, T5, TL, TR	LUMINOUS RINGS COLOR OPTION		UCM		MDG	Medium Grey	LDL	Lightly diffused lens
Color	56LED-3K, 56LED-4K, 56LED-5K	BL	Blue inner lens	700	700mA drive current, 75 watts	ATG	Antique Green	PCA-C	Rotatable photocell housing-contemporary
Driver	700 (700mA, 132 watts) 450 (450mA, 85 watts)	RD	Red inner lens	UCL		LGY	Light Grey	SCP	Programmable motion control, factory default is 50%, requires pole.
Bezel Fishes	Available in 13 standard finishes and premium finishes	GRN	Green inner lens	700	700mA drive current, 132 watts	RAL/PREMIUM COLOR	Provide a RAL 4 digit color number		
		DISTRIBUTION		450	450mA drive current, 85 watts	CUSTOM COLOR	Please provide a color chip for matching		
		T2	Type 2						
		T3	Type 3						
		T4	Type 4						
		T5	Type 5						
		TL	45° Left						
		TR	45° Right						

Please visit www.aal.net for mounting, dimensions, weight and EPA.