



VIII.C

690 Chesterfield Pkwy W • Chesterfield MO 63017-0760
Phone: 636-537-4000 • Fax 636-537-4798 • www.chesterfield.mo.us

Planning Commission Staff Report

Subject: **Vote Report**

Meeting Date: September 8, 2008

From: Shawn P. Seymour, Project Planner

Location: (17V340143)

Petition: P.Z. 19-2008 Spirit Trade center Plat 2 Lot 15 (Joan Lee LLC)

Proposal Summary

Joan Lee, LLC. has submitted an application for a change of zoning, from an "M3" Planned Industrial District to a "PI" Planned Industrial District per the regulations of the City of Chesterfield Zoning Ordinance Section 1003.140. The site is located on the southeast corner of the intersection of Chesterfield Airport Road and Trade Center Boulevard (17V340143).

Staff Recommendation

The Attachment A for this request meets all of the development requirements of the City of Chesterfield and therefore, Staff requests action on the change of zoning from "M3" Planned Industrial District to a "PI" Planned Industrial District.

Zoning Analysis

A preliminary plan accompanies all rezoning requests when the change of zoning is to a Planned District. When a vote is taken on a rezoning request, the vote is to approve the change of zoning with an Attachment A written by Staff. The vote is not to approve the accompanying preliminary plan which is provided for informational purposes only.

The petitioner is requesting the change of zoning to permit a retail use on a developed site. The adding of the use in this case requires a zoning change due to the site being zoned "M3" Planned Industrial District, a St. Louis County zoning district that is no longer used by the City of Chesterfield. Modifications made to the Attachment A will include adding the retail use to those uses already permitted and updating development standards to bring the governing ordinance up to current City of Chesterfield Code.

Surrounding Land Use and Zoning

The land use and zoning for the properties surrounding this parcel are as follows:

North: The property to the north across Chesterfield Airport Road is Terra Corporate Park and is zoned "PI" Planned Industrial District.
East: The property to the east is Chesterfield Industrial Park and is zoned "PI" Planned Industrial District.
South & West: The property to the south & west is Spirit Trade Center and is zoned "M3" Planned Industrial District



View looking southeast at the site



View looking southwest at the site

Comprehensive Plan Analysis

The subject site is located in the Chesterfield Valley an area of Ward 4 of the City of Chesterfield. The Comprehensive Plan calls for this area to be Service Business Park and is defined as; the area south of Chesterfield Airport Rd. west of Chesterfield Industrial Park and east of Goddard Ave. should be developed for uses needing more intensive warehousing and manufacturing operations. These uses would be similar to the type of development associated with the Spirit of St. Louis Airport. The subject site is not located in any sub area of the Comprehensive Plan.

Site Area History

In May of 1988, St. Louis County approved Ordinance 13,935 granting the approval of the Spirit Trade Center Development an "M3" Planned Industrial District. In March of 1992, the City of Chesterfield approved Ordinance 656 which adopted St. Louis County Ordinance 13,935 but amended said ordinance to grant the dedication of right-of-way allowances to the City of Chesterfield and to amend the landscape bond information.

Issues

A public hearing was held for this request on August 25, 2008. At the hearing, two issues were identified and the petitioner has addressed the same in the attached letter.

The following issues have been addressed:

1. The applicant has agreed to remove uses (ss) Railroad switching yards and (III) Terminals for trucks, buses, railroads, and watercraft from the list of proposed uses.
2. Planning Commission requested that Staff provide a list of the approved uses at the surrounding developments. A list of the approved uses for the surrounding developments is attached.

Request

Staff requests action on the Attachment A as written by the Department of Planning & Public Works for P.Z. 19-2008 Spirit Trade Center Plat 2 Lot 15 (Joan Lee LLC).

Respectfully submitted,



Shawn P. Seymour, AICP
Project Planner

Respectfully submitted,



Mara M. Perry, AICP
Senior Planner

Attachments:

1. Attachment A
2. Applicants Response to Issues Letter
3. List of Surrounding Developments Approved Uses
4. Approved Second Amended Site Development Section Plan

ATTACHMENT A

All provisions of the City of Chesterfield City Code shall apply to this development except as specifically modified herein.

I. SPECIFIC CRITERIA

A. PERMITTED USES

1. The uses allowed in this "PI" District shall be:
 - a. Broadcasting studios for radio and television.
 - b. Business, professional, and technical training schools.
 - c. Business service establishments.
 - d. Cafeterias for employees and guests only.
 - e. Child care centers, nursery schools, and day nurseries.
 - f. Churches shall be allowed on tracts of land of at least one (1) acre in area.
 - g. Financial institutions.
 - h. Gymnasiums, indoor swimming pools, indoor handball and racquetball courts (public or private), and indoor and unlighted outdoor tennis courts (public or private).
 - i. Hotels and motels.
 - j. Laundries and dry cleaning plants, which include dry cleaning drop-off and pick-up stations.
 - k. Local public utility facilities, provided that any installation, other than poles and equipment attached to the poles, shall be:
 - (i) Adequately screened with landscaping, fencing or walls, or any combination thereof; or
 - (ii) Placed underground; or
 - (iii) Enclosed in a structure in such a manner so as to blend with and complement the character of the surrounding area.

All plans for screening these facilities shall be submitted to the Department of Planning for review. No building permit or

installation permit shall be issued until these plans have been approved by the Department of Planning.

- l. Mail order sale warehouses.
- m. Manufacturing, fabrication, assembly, processing, or packaging of any commodity except:
 - (i) Facilities producing or processing explosives or flammable gases or liquids;
 - (ii) Facilities for animal slaughtering, meat packing, or rendering;
 - (iii) Sulphur plants, rubber reclamation plants, or cement plants; and
 - (iv) Steel mills, foundries, or smelters.
- n. Medical and dental offices.
- o. Mortuaries.
- p. Offices or office buildings.
- q. Parking areas, including garages, for automobiles, but not including any sales of automobiles, or the storage of wrecked or otherwise damaged and immobilized automotive vehicles for a period in excess of seventy-two (72) hours.
- r. Plumbing, electrical, air conditioning, and heating equipment sales, warehousing and repair facilities.
- s. Police, fire, and postal stations.
- t. Printing and duplicating services.
- u. Public utility facilities.
- v. Radio, television, and communication studios, transmitting or relay towers, antennae, and other such facilities no greater in height than two hundred (200) feet above the average ground elevation at the perimeter of such structure.
- w. Recreational facilities, indoor and illuminated outdoor facilities, including swimming pools, golf courses, golf practice driving ranges, tennis courts, and gymnasiums, and indoor theaters, including drive-in theaters.
- x. Research facilities, professional and scientific laboratories, including photographic processing laboratories used in conjunction therewith.

- y. Restaurants, fast food.
 - z. Restaurants, sit down.
 - aa. Sales, rental, and leasing of new and used vehicles, including automobiles, trucks, trailers, construction equipment, agricultural equipment, and boats, as well as associated repairs and necessary outdoor storage of said vehicles.
 - bb. Sales, servicing, repairing, cleaning, renting, leasing, and necessary outdoor storage of equipment and vehicles used by business, industry, and agriculture.
 - cc. Schools for business, professional, or technical training requiring outdoor areas for driving or heavy equipment training.
 - dd. Service facilities, studios, or work areas for antique salespersons, artists, candy makers, craftpersons, dressmakers, tailors, music teachers, dance teachers, typists, and stenographers, including cabinet makers, film processors, fishing tackle and bait shops, and souvenir sales. Goods and services associated with these uses may be sold or provided directly to the public on the premises.
 - ee. Stores, shops, markets, service facilities, and automatic vending facilities in which goods or services of any kind, including indoor sale of motor vehicles, are being offered for sale or hire to the general public on the premises.
 - ff. Union halls and hiring halls.
 - gg. Vehicle repair facilities.
 - hh. Vehicle service centers.
 - ii. Vehicle washing facilities.
 - jj. Warehousing, storage, or wholesaling of manufactured commodities, explosives, or flammable gases and liquids.
 - kk. Yards for storage of contractors' equipment, materials, and supplies, excluding junk yards and salvage yards.
2. The ancillary uses permitted in this "PI" District shall be:
- a. Automatic vending facilities for:
 - (i) Ice and solid carbon dioxide (dry ice);
 - (ii) Beverages; and
 - (iii) Confections.

3. Hours of Operation.

Hours of operation for this "PI" District shall not be restricted.

B. FLOOR AREA, HEIGHT, BUILDING AND PARKING STRUCTURE REQUIREMENTS

1. BUILDING REQUIREMENTS

A minimum of thirty percent (30%) open space is required for this development.

C. SETBACKS

1. STRUCTURE SETBACKS

No building or structure, other than: a freestanding project identification sign, light standards, or flag poles will be located within the following setbacks:

- a. Thirty (30) feet from the right-of-way of Chesterfield Airport Road on the northern boundary of the "PI" Planned Industrial District.
- b. Fifteen (15) feet from the western boundary of the "PI" Planned Industrial District.
- c. Fifteen (15) feet from the eastern boundary of the "PI" Planned Industrial District.
- d. Thirty (30) feet from the southern boundary of the "PI" Planned Industrial District.

2. Parking Setbacks

No parking stall, loading space, internal driveway, or roadway, except points of ingress or egress, will be located within the following setbacks:

- a. Ten (10) feet from the right-of-way of Chesterfield Airport Road on the northern boundary of this "PI" Planned Industrial District.
- b. Ten (10) feet from the western boundary of the "PI" Planned Industrial District.
- c. Ten (10) feet from the eastern boundary of the "PI" Planned Industrial District.
- d. Ten (10) feet from the southern boundary of the "PI" Planned Industrial District.

D. PARKING AND LOADING REQUIREMENTS

1. Parking and loading spaces for this development will be as required in the City of Chesterfield Code.
2. Construction Parking
 - a. No construction parking shall be permitted within the Chesterfield Airport Road and Trade Center Boulevard rights-of-way.

E. LANDSCAPE AND TREE REQUIREMENTS

The developer shall adhere to the Tree Manual of the City of Chesterfield Code.

F. SIGN REQUIREMENTS

1. Ornamental Entrance Monument construction, if proposed, shall be reviewed by the City of Chesterfield, and/or the St. Louis County Department of Highways and Traffic, for sight distance considerations prior to installation or construction.
2. Signs shall be permitted in accordance with the regulations of the City of Chesterfield Code.
3. No advertising signs shall be permitted in this development.

G. LIGHT REQUIREMENTS

Provide a lighting plan and cut sheet in accordance with the City of Chesterfield Code.

H. ARCHITECTURAL

1. The developer shall submit architectural elevations, including but not limited to, colored renderings and building materials. Architectural information is to be reviewed by the Architectural Review Board and the Planning Commission.
2. Building facades should be articulated by using color, arrangement or change in materials to emphasize the facade elements. The planes of the exterior walls may be varied in height, depth or direction. Extremely long facades shall be designed with sufficient building articulation and landscaping to avoid a monotonous or overpowering appearance.
3. Trash enclosures: The location, material, and elevation of any trash enclosures will be as approved by the Planning Commission on the Site Development Plan. All exterior trash areas will be enclosed with a six (6)

foot high sight-proof enclosure complimented by adequate landscaping approved by the Planning Commission on the Site Development Plan.

4. Mechanical equipment will be adequately screened by roofing or other material as approved by the Planning Commission.

I. ACCESS/ACCESS MANAGEMENT

1. No direct access shall be allowed to Chesterfield Airport Road.
2. Provide cross access easements to provide the adjacent parcel to the south full access to Trade Center Boulevard, as directed by the City of Chesterfield.

M. POWER OF REVIEW

The Mayor or a Councilmember of the Ward in which a development is proposed may request that the Site Development Plan be reviewed and approved by the entire City Council. This request must be made no later than 24 hours before posting the agenda for the next City Council meeting after Planning Commission review and approval of the Site Development Plan. The City Council will then take appropriate action relative to the proposal.

N. STORM WATER AND FLOODPLAIN

1. The Chesterfield Valley Master Storm Water Plan indicates a 30' flat bottom ditch shall be constructed along the southern portion of the east property line of this site and that drainage from this site is to be directed to the south. The developer shall be responsible for construction of the required storm water improvements and coordination with the owners of the properties affected by construction of the required improvements. In the event that the ultimate required improvements cannot be constructed concurrently with this development, the developer shall provide interim drainage facilities and establish sufficient escrows as guarantee of future construction of the required improvements, including removal of interim facilities. Interim facilities shall be sized to handle runoff from the 100-year, 24-hour storm event as produced by the Master Storm Water Plan model. The interim facilities shall provide positive drainage and may include a temporary pump station, if necessary. Interim facilities shall be removed promptly after the permanent storm water improvements are constructed.

The developer may elect to propose alternate geometry, size and/or type of storm water improvements that are functionally equivalent to the required improvements. Functional equivalence is said to be achieved when, as determined by the Director of Public Works, the alternate proposal provides the same hydraulic function, connectivity, and system-wide benefits without adversely affecting any of the following: water surface profiles at any location outside the development; future capital expenditures; maintenance obligations; equipment needs; frequency of

maintenance; and probability of malfunction. The City will consider, but is not obligated to accept, the developer's alternate plans. If the Director of Public Works determines that the developer's proposal may be functionally equivalent to the Chesterfield Valley Master Storm Water Plan improvements, hydraulic routing calculations will be performed to make a final determination of functional equivalence. The Director will consider the developer's proposal, but is not obligated to have the hydraulic analysis performed if any of the other criteria regarding functional equivalence will not be met. The hydraulic routing calculations regarding functional equivalence may be performed by a consultant retained by the City of Chesterfield. The developer shall be responsible for all costs related to consideration of an alternate proposal, which shall include any costs related to work performed by the consultant.

2. Provide a Chesterfield Valley Storm Water Easement along the east property line to accommodate the future construction of the Chesterfield Valley Master Storm Water Plan channel in that area, and depict the channel on the Site Development Plan and improvement plans. Maintenance of the required channel shall be the responsibility of the property owner.
3. All Chesterfield Valley Master Storm Water Plan improvements shall be operational prior to the paving of any driveways or parking areas.

O. GEOTECHNICAL REPORT

Prior to Site Development Plan approval, provide a geotechnical report, prepared by a registered professional engineer licensed to practice in the State of Missouri, as directed by the Department of Planning and Public Works. The report shall verify the suitability of grading and proposed improvements with soil and geologic conditions and address the existence of any potential sinkhole, ponds, dams, septic fields, etc., and recommendations for treatment. A statement of compliance, signed and sealed by the geotechnical engineer preparing the report, shall be included on all Site Development Plans and Improvement Plans.

P. MISCELLANEOUS

1. All utilities will be installed underground.

II. TIME PERIOD FOR SUBMITTAL OF SITE DEVELOPMENT CONCEPT PLANS AND SITE DEVELOPMENT PLANS

- A. The developer shall submit a concept plan within eighteen (18) months of City Council approval of the change of zoning.
- B. In lieu of submitting a Site Development Concept Plan and Site Development Section Plans, the petitioner may submit a Site Development Plan for the entire development within eighteen (18) months of the date of approval of the change of zoning by the City.

- C. Failure to comply with these submittal requirements will result in the expiration of the change of zoning and will require a new public hearing.
- D. Said Plan shall be submitted in accordance with the combined requirements for Site Development Section and Concept Plans. The submission of Amended Site Development Plans by sections of this project to the Planning Commission shall be permitted if this option is utilized.
- E. Where due cause is shown by the developer, this time interval for plan submittal may be extended through appeal to and approval by the Planning Commission.

III. COMMENCEMENT OF CONSTRUCTION

- A. Substantial construction shall commence within two (2) years of approval of the site development concept plan or site development plan, unless otherwise authorized by ordinance.
- B. Where due cause is shown by the developer, the Commission may extend the period to commence construction for not more than one additional year.

IV. GENERAL CRITERIA

A. SITE DEVELOPMENT PLAN SUBMITTAL REQUIREMENTS

The Site Development Plan shall include, but not be limited to, the following:

1. Location map, north arrow, and plan scale. The scale shall be no greater than one (1) inch equals one hundred (100) feet.
2. Outboundary plat and legal description of property.
3. Density calculations.
4. Parking calculations. Including calculation for all off street parking spaces, required and proposed, and the number, size and location for handicap designed.
5. Provide open space percentage for overall development including separate percentage for each lot on the plan.
6. Provide Floor Area Ratio (F.A.R.).
7. A note indicating all utilities will be installed underground.
8. A note indicating signage approval is separate process.
9. Depict the location of all buildings, size, including height and distance from adjacent property lines and proposed use.

10. Specific structure and parking setbacks along all roadways and property lines.
11. Indicate location of all existing and proposed freestanding monument signs
12. Zoning district lines, subdivision name, lot number, dimensions, and area, and zoning of adjacent parcels where different than site.
13. Floodplain boundaries.
14. Depict existing and proposed improvements within 150 feet of the site as directed. Improvements include, but are not limited to, roadways, driveways and walkways adjacent to and across the street from the site, and significant natural features, such as wooded areas and rock formations, that are to remain or be removed.
15. Depict all existing and proposed easements and rights-of-way within 150 feet of the site and all existing or proposed off-site easements and rights-of-way required for proposed improvements.
16. Indicate the location of the proposed storm sewers, detention basins, sanitary sewers and connection(s) to the existing systems.
17. Depict existing and proposed contours at intervals of not more than one (1) foot, and extending 150 feet beyond the limits of the site as directed.
18. Address trees and landscaping in accordance with the City of Chesterfield Code.
19. Comply with all preliminary plat requirements of the City of Chesterfield Subdivision Regulations per the City of Chesterfield Code.
20. Signed and sealed in conformance with the State of Missouri Department of Economic Development, Division of Professional Registration, Missouri Board for Architects, Professional Engineers and Land Surveyors requirements.
21. Provide comments/approvals from the appropriate Fire District, the Metropolitan St. Louis Sewer District, Monarch Levee District, Spirit of St. Louis Airport and the Missouri Department of Transportation.
22. Compliance with Sky Exposure Plane.

VII. RECORDING

Within 60 days of approval of any development plan by the City of Chesterfield, the approved Plan will be recorded with the St. Louis County Recorder of Deeds. Failure to

do so will result in the expiration of approval of said plan and require re-approval of a plan by the Planning Commission.

VIII. ENFORCEMENT

- A. The City of Chesterfield, Missouri will enforce the conditions of this ordinance in accordance with the Site Development Plan approved by the City of Chesterfield and the terms of this Attachment A.
- B. Failure to comply with any or all the conditions of this ordinance will be adequate cause for revocation of approvals/permits by reviewing Departments and Commissions.
- C. Non-compliance with the specific requirements and conditions set forth in this Ordinance and its attached conditions or other Ordinances of the City of Chesterfield shall constitute an ordinance violation, subject, but not limited to, the penalty provisions as set forth in the City of Chesterfield Code.
- D. Waiver of Notice of Violation per the City of Chesterfield Code.
- E. This document shall be read as a whole and any inconsistency to be integrated to carry out the overall intent of this Attachment A.

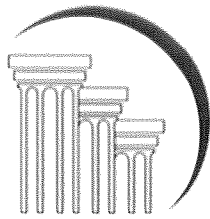

DOSTERGUIN
JAMES ULLOM BENSON & MUNDORF, L.L.C.
ATTORNEYS AT LAW

St. Louis
17107 Chesterfield Airport Rd.
Suite 300
Chesterfield, MO 63005
(636) 532-0042
(636) 532.1082 Fax

William B. Remis
wremis@dosterguin.com

August 29, 2008

VIA EMAIL AND FIRST CLASS MAIL

Shawn Seymour, AICP
Project Planner
Department of Planning & Public Works
City of Chesterfield
690 Chesterfield Parkway West
Chesterfield, Missouri 63017-0760

RE: P.Z. 19-2008 Spirit Trade Center, Plat 2, Lot 15 (Joan Lee, LLC)

Dear Mr. Seymour:

We are in receipt of your August 27, 2008 letter and offer the following responses:

ISSUES:

- 1. Many of the proposed uses are unfeasible with the current surrounding built landscape; consideration should be given to removing these uses.**

Petitioner's Response: Petitioner will agree to delete the following uses: (ss) Railroad switching yards and (lll) Terminals for trucks, buses, railroads and watercraft.

The following conditions related to site specific issues will be applied to the petition:

Setbacks

1. STRUCTURE SETBACKS

No building or structure, other than: a freestanding project identification sign, boundary and retaining walls, light standards, or flag poles will be located within the following setbacks:

- a. Thirty (30) feet from the right-of-way of Chesterfield Airport Road.**
- b. Fifteen (15) feet from the west property line of this development.**
- c. Fifteen (15) feet from the east property line of this development.**
- d. Thirty (30) feet from south property line of this development.**

2. PARKING SETBACKS

No parking stall, loading space, internal driveway, or roadway, except points of ingress or egress with the exception of shared driveways, will be located within the following setbacks:

- a. Ten (10) feet from the right-of-way of Chesterfield Airport Road.
- b. Ten (10) feet from the west property line of this development.
- c. Ten (10) feet from the east property line of this development.
- d. Ten (10) feet from the south property line of this development.

Petitioner's Response: Petitioner acknowledges this requirement.

Access

- 1. No direct access shall be allowed to Chesterfield Airport Road.**

Petitioner's Response: Petitioner acknowledges this requirement.

- 2. Provide cross access easements to provide the adjacent parcel to the south full access to Trade Center Boulevard, as directed by the City of Chesterfield.**

Petitioner's Response: Petitioner acknowledges this requirement.

Parking

- 3. No construction parking shall be permitted within the Chesterfield Airport Road and Trade Center Boulevard rights of way.**

Petitioner's Response: Petitioner acknowledges this requirement.

Storm Water and Floodplain

- 4. The Chesterfield Valley Master Storm Water Plan indicates a 30' flat bottom ditch shall be constructed along the southern portion of the east property line of this site and that drainage from this site is to be directed to the south. The developer shall be responsible for construction of the required storm water improvements and coordination with the owners of the properties affected by construction of the required improvements. In the event that the ultimate required improvements cannot be constructed concurrently with this development, the developer shall provide interim drainage facilities and establish sufficient escrows as guarantee of future construction of the required improvements, including removal of interim facilities. Interim facilities shall be sized to handle runoff from the 100-year, 24-hour storm event as produced by the Master Storm Water Plan model. The interim**

facilities shall provide positive drainage and may include a temporary pump station, if necessary. Interim facilities shall be removed promptly after the permanent storm water improvements are constructed.

The developer may elect to propose alternate geometry, size and/or type of storm water improvements that are functionally equivalent to the required improvements. Functional equivalence is said to be achieved when, as determined by the Director of Public Works, the alternate proposal provides the same hydraulic function, connectivity, and system-wide benefits without adversely affecting any of the following: water surface profiles at any location outside the development; future capital expenditures; maintenance obligations; equipment needs; frequency of maintenance; and probability of malfunction. The City will consider, but is not obligated to accept, the developer's alternate plans. If the Director of Public Works determines that the developer's proposal may be functionally equivalent to the Chesterfield Valley Master Storm Water Plan improvements, hydraulic routing calculations will be performed to make a final determination of functional equivalence. The Director will consider the developer's proposal, but is not obligated to have the hydraulic analysis performed if any of the other criteria regarding functional equivalence will not be met. The hydraulic routing calculations regarding functional equivalence may be performed by a consultant retained by the City of Chesterfield. The developer shall be responsible for all costs related to consideration of an alternate proposal, which shall include any costs related to work performed by the consultant.

Petitioner's Response: Petitioner will address this comment in the event Petitioner elects to make significant changes to the building or site layout.

5. **Provide a Chesterfield Valley Storm Water Easement along the east property line to accommodate the future construction of the Chesterfield Valley Master Storm Water Plan channel in that area, and depict the channel on the Site Development Plan and improvement plans. Maintenance of the required channel shall be the responsibility of the property owner.**

Petitioner's Response: Petitioner will address this comment in the event Petitioner elects to make significant changes to the building or site layout.

6. **All Chesterfield Valley Master Storm Water Plan improvements shall be operational prior to the paving of any driveways or parking areas.**

Petitioner's Response: Petitioner will address this comment in the event Petitioner elects to make significant changes to the building or site layout.

Furthermore, the Department of Planning and Public Works recommends the following standard general conditions be applied to the petition; no other general conditions apply. Please note, any modification to the standard wording of these general conditions is set in bold font to facilitate identification.

Geotechnical Report

G-4. Prior to Site Development Plan approval, provide a geotechnical report, prepared by a registered professional engineer licensed to practice in the State of Missouri, as directed by the Department of Planning and Public Works. The report shall verify the suitability of grading and proposed improvements with soil and geologic conditions and address the existence of any potential sinkhole, ponds, dams, septic fields, etc., and recommendations for treatment. A statement of compliance, signed and sealed by the geotechnical engineer preparing the report, shall be included on all Site Development Plans and improvement plans.

Petitioner's Response: Petitioner will address this comment in the event Petitioner elects to make significant changes to the building or site layout.

Site Development Section Plan Submittal Requirements

G-5. Depict existing and proposed contours, at intervals of not more than one (1) foot.

Petitioner's Response: Petitioner will address this comment in the event Petitioner elects to make significant changes to the building or site layout.

Finally, the petitioner should be advised of the following requirements of the City Code which may impact the project during the later stages of the development process.

- **A portion of the site is located in the floodplain. Consult Chapter 14 of the City Code for specific requirements.**
- **Access management principals to be applied to this development can be found in Chapter 26 of the City Code.**

Petitioner's Response: Petitioner acknowledges these requirements.

Very truly yours,



William B. Remis

WBR:db
cc: Kelly Taylor
Mike Doster

Terra Corporate Park:

- a. Animal hospitals, veterinary clinics, and kennels.
- b. Auditoriums, Churches, clubs, lodges, meeting rooms, libraries, reading rooms, theaters, or any other facility for public assembly.
- c. Automatic vending facilities for:
 - i. Ice and solid carbon dioxide (dry ice);
 - ii. Beverages;
 - iii. Confections.
- d. Broadcasting studios for radio and television.
- e. Business, professional, and technical training schools.
- f. Business service establishments.
- g. Cafeterias for employees and guests only.
- h. Child care centers, nursery schools, and day nurseries.
- i. Churches shall be allowed on tracts of land of at least one acre in area.
- j. Filling Stations.
- k. Financial Institutions.
- l. Gymnasiums, indoor swimming pools, indoor handball and racquetball courts (public and private), and indoor and unlighted outdoor tennis courts (public and private).
- m. Hotels and motels.
- n. Mail order sale warehouses.
- o. Manufacturing, fabrication, assembly, processing or packaging of any commodity except:
 - i. Facilities producing or processing explosives or flammable gases or liquids;
 - ii. Facilities for animal slaughtering, meat packing, or rendering;
 - iii. Sulphur plants, rubber reclamation plants, or cement plants; and
 - iv. Steel mills, foundries, or smelters.
- p. Medical and dental offices.
- q. Mortuaries.
- r. Offices or office buildings.
- s. Outpatient substance abuse treatment facilities.
- t. Parking areas, including garages, for automobiles, but not including any sales of automobiles, or the storage of wrecked or otherwise damaged and immobilized automotive vehicles for a period in excess of seventy-two (72) hours.
- u. Plumbing, electrical, air conditioning, and heating equipment sales, warehousing and repair facilities.
- v. Police, fire and postal stations.
- w. Printing and duplicating services.
- x. Public utility facilities.
- y. Recreational facilities, indoor and illuminated outdoor facilities, including swimming pools, golf courses, golf practice driving ranges, tennis courts, and gymnasiums, and indoor theaters, including drive-in theaters (indoor use only).
- z. Research facilities, professional and scientific laboratories, including photographic processing laboratories used in conjunction therewith.
- aa. Restaurants, fast food.
- bb. Restaurants, sit down.

- cc. Service facilities, studios, or work areas for antique salespersons, artists, candy makers, craftpersons, dressmakers, tailors, music teachers, dance teachers, typists, and stenographers, including cabinet makers, film processors, fishing tackle and bait shops, and souvenir sales. Goods and services associated with these uses may be sold or provided directly to the public on the premises.
- dd. Sewage treatment facilities, as approved by the appropriate regulatory agency.
- ee. Permitted signs (See City of Chesterfield Code).
- ff. Stores, shops, markets, service facilities, and automatic vending facilities in which goods or services of any kind, including indoor sale of motor vehicles, are being offered for sale or hire to the general public on the premises.
- gg. Union halls and hiring halls.

Chesterfield Industrial Park:

- a. Associate work and storage areas required by a business, firm or service to carry on business operations.
- b. Barber shops and beauty parlors.
- c. Bookstores.
- d. Dry cleaning drop-off and pick up stations.
- e. Financial institutions.
- f. Medical and dental offices.
- g. Offices or office buildings.
- h. Restaurants, fast food.
- i. Restaurants, sit down.
- j. Schools for business, professional, or technical training, but not including outdoor areas for driving or heavy equipment training.
- k. Service facilities, studios, or work areas for antique salespersons, artists, candy makers, craft persons, dressmakers, tailors, music teachers, dance teachers, typists, and stenographers, including cabinet makers, film processors, fishing tackle and bait shops, and souvenir sales, goods and services associated with these uses may be sold or provided directly to the public on the premises.
- l. Stores, shops, markets, service facilities, and automatic vending facilities in which goods or services of any kind, including indoor sale of motor vehicles, are being offered for sale or hire to the general public on the premises.

Spirit Industrial Park:

- a. Business, professional, and technical training schools.
- b. Laundries and dry cleaning plants, not including personal and individual drop-off and pick-up service.
- c. Manufacturing, fabrication, assembly, processing, or packaging of any commodity from semi-finished materials, except explosives or flammable gases or liquids.
- d. Offices or office buildings.
- e. Parking areas, including garages.
- f. Police, fire, and postal stations.
- g. Printing and duplicating services.
- h. Public utility facilities.

- i. Radio, television, and communication studios, transmitting or relay towers, antennae, and other such facilities no greater in height than two hundred (200) feet above the average finished ground elevation at the perimeter of such structure.
- j. Railroad switching yards.
- k. Research laboratories and facilities.
- l. Sales and renting of equipment and vehicles used by business, industry, and agriculture, excluding retail automobile sales.
- m. Terminals for trucks, buses, railroads, and watercraft.
- n. Union halls and hiring halls.
- o. Wholesaling or warehousing of manufactured commodities except live animals, explosives, or flammable gases.
- p. Yards for storage of contractors' equipment, materials, and supplies, excluding junk yards and salvage yards.
- q. Devices for the generation of energy, such as solar panels, wind generators, and similar devices.
- r. Dwelling or lodging units, only for watchmen, caretakers, or other personnel whose residence is essential to the operation of a permitted or conditional use or uses.
- s. Individual sewage treatment facilities serving an individual building or use, as approved by the appropriate regulatory agency. The sewage treatment facility shall not exceed five thousand (5,000) gallons per day flow.
- t. Airports, landing strips, and heliports.
- u. Business service establishments.
- v. Filling stations, including emergency towing and repair services.
- w. Gymnasiums, indoor swimming pools, indoor handball and racquetball courts (public or private) and indoor and unlighted outdoor tennis courts (public or private).
- x. Incinerators.
- y. Manufacturing of explosives and flammable gases and liquids.
- z. Radio, television, and communication studios, transmitting or relay towers, antennae, and other such facilities greater in height than two hundred (200) feet above the average finished ground elevation at the perimeter of such structure.
- aa. Restaurants.
- bb. Sales yards operated by a charitable purposes by a church, school, or other not for profit organization.
- cc. Satellite dishes (additional to provision of Section 1003.167,17.).
- dd. Towed vehicle storage yards wherein no individual vehicle may be stored for a period exceeding ninety (90) days, and involving no auto repair and no salvage or sale of automobile parts. A ten-foot high sight-proof fence shall be provided along all limits of the property.
- ee. Sewage treatment facilities.
- ff. Vehicle repair facilities.
- gg. Vehicle service centers.
- hh. Warehousing, storage, or wholesaling of live animals, explosives, or flammable gases and liquids.
- ii. Churches shall be allowed on tracts of land at least one acre in area.

SECOND AMENDED SITE DEVELOPMENT SECTION PLAN

OF

A TRACT OF LAND BEING ALL OF ADJUSTED LOT 15 OF THE BOUNDARY ADJUSTMENT PLAT OF LOTS 15 AND 16 OF SPIRIT TRADE CENTER PLAT TWO AS RECORDED IN PLAT BOOK 348, PAGE 772 AND AMENDED BY SURVEYOR'S AFFIDAVIT RECORDED IN BOOK 12528 PAGE 2491 LOCATED IN U.S. SURVEY 1010, TOWNSHIP 45 NORTH, RANGE 3 EAST OF THE 5TH PRINCIPAL MERIDIAN CITY OF CHESTERFIELD, ST. LOUIS COUNTY, MISSOURI

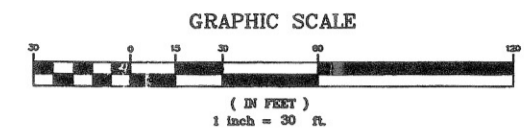
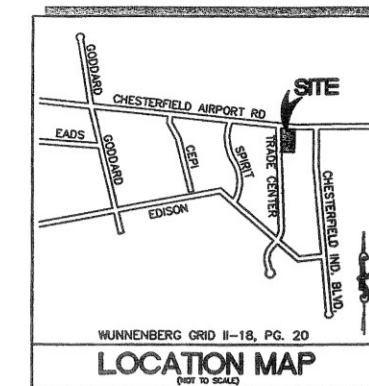

- LEGEND**
- EXISTING SANITARY SEWER
 - EXISTING STORM SEWER
 - EXISTING TREE
 - EXISTING BUILDING
 - EXISTING CONTOUR
 - SPOT ELEVATION
 - EXISTING UTILITIES
 - FOUND 1/2" IRON PIPE
 - SET IRON PIPE
 - FOUND CROSS
 - FOUND STONE
 - FIRE HYDRANT
 - LIGHT STANDARD
 - BUSH
 - SIGN
 - NOTES PARKING SPACES
 - GUY WIRE
 - POWER POLE
 - WATER VALVE
 - DENOTES RECORD INFORMATION
 - HANDICAPPED PARKING
- ABBREVIATIONS**
- C.O. - CLEANOUT
 - DB. - DEED BOOK
 - E. - ELECTRIC
 - FL. - FLOWLINE
 - FT. - FEET
 - FND. - FOUND
 - G. - GAS
 - M.H. - MANHOLE
 - N/F. - NOW OR FORMERLY
 - P.B. - PLAT BOOK
 - PG. - PAGE
 - P.V.C. - POLYVINYL CHLORIDE PIPE
 - R.C.P. - REINFORCED CONCRETE PIPE
 - SO. - SQUARE
 - T. - TELEPHONE CABLE
 - TYP. - TYPICAL
 - V.C.P. - VETRIFIED CLAY PIPE
 - W. - WATER
 - (86'W) - RIGHT-OF-WAY WIDTH

PERTINENT DATA

OWNER: JOAN LEE, L.L.C.
 DB. 14143, PG. 628

ZONING: M-3 - ORDINANCE 656 AMENDING ORD. 13,935

ORDINANCE: ORDINANCE 655 AMENDING ORD. 13,935

LOCATOR NUMBER: LOT 15 1794-0143

SITE AREA: 3.122 Acres ±

FIRE DISTRICT: CHESTERFIELD FIRE PROTECTION DISTRICT

SCHOOL DISTRICT: ROCKWOOD R-6

SEWER DISTRICT: M.S.D.

WATER SHED: BONHOMME CREEK

WATER SERVICE: ST. LOUIS CO. WATER COMPANY

GAS SERVICE: LACLEDE GAS COMPANY

ELECTRIC SERVICE: AMERENUE ELECTRIC COMPANY

PHONE SERVICE: S.W.B.T.

SITE ADDRESS: 17760 CHESTERFIELD AIRPORT RD. CHESTERFIELD, MO 63005

LEGAL DESCRIPTION

Adjusted Lot 15 of the "Boundary Adjustment Plat of Lots 15 and 16 of Spirit Trade Center Plat Two," a subdivision in the County of St. Louis, Missouri, according to the plat thereof recorded in Plat Book 348 Page 772 of the St. Louis County Records.

- GENERAL NOTES**
- BOUNDARY AND TOPOGRAPHIC SURVEY BY STOCK & ASSOCIATES CONSULTING ENGINEERS, INC.
 - ALL UTILITIES SHOWN HAVE BEEN LOCATED BY THE ENGINEER FROM AVAILABLE RECORDS. THEIR LOCATION SHOULD BE CONSIDERED APPROXIMATE. THE CONTRACTOR HAS THE RESPONSIBILITY TO NOTIFY ALL UTILITY COMPANIES, PRIOR TO CONSTRUCTION, TO HAVE EXISTING UTILITIES FIELD LOCATED.
 - NO GRADE SHALL EXCEED ±1 SLOPE.
 - PARKING CALCULATIONS:
 - PARKING REQUIRED:
 - OFFICE: 16,100 S.F./1,000 x 3 1/3 = 54 SPACES
 - WAREHOUSE: 2 SPACES/3 EMPLOYEES x 15 = 10 SPACES
 - STANDARD 9'x19' = 64 SPACES
 - HANDICAP = 4 SPACES
 - TOTAL REQUIRED = 68 SPACES
 - LOADING = 2 SPACES
 - PARKING PROVIDED:
 - STANDARD 9'x19' = 93 SPACES
 - HANDICAP = 4 SPACES
 - TOTAL = 97 SPACES
 - LOADING PROVIDED = 8 SPACES
 - GREENSPACE CALCULATIONS:
 - PAVEMENT AREA: 56,776 S.F. = 42%
 - BUILDING AREA: 42,661 S.F. = 31%
 - GREEN AREA: 36,573 S.F. = 27%
 - SITE AREA: 136,010 S.F.
 - FLOOR/AREA RATIO: 42,661/136,010 = 0.31
 - GRADING AND STORM WATER PER M.S.D. AND THE CITY OF CHESTERFIELD, MISSOURI
 - STORMWATER SHALL BE DISCHARGED AT ADEQUATE NATURAL DISCHARGE POINT.
 - NO STEP ALLOWED AT ACCESSIBLE ENTRANCE DOORS.
 - ADA RAMPS SHALL BE CONSTRUCTED AT ALL ENTRANCES.
 - THIS SITE IS LOCATED IN ZONE "X", AREAS OF 500 YEAR FLOOD: AREAS OF 100 YEAR FLOOD WITH AVERAGE DEPTHS LESS THAN 1 FOOT OR WITH DRAINAGE AREAS LESS THAN 1 SQUARE MILE; AND AREAS PROTECTED BY LEVEES FROM 100 YEAR FLOOD. TAKEN FROM F.I.R.M. NO. 29186C0120H - 8/2/95. (LOMR 04/17/00) ALSO, THIS SITE IS LOCATED WITHIN ZONE "AH", AREAS OF 100 YEAR FLOOD: FLOOD DEPTHS OF 1 TO 3 FEET (USUALLY AREAS OF PONDING) TAKEN FROM F.I.R.M. NO. 29186C0120H - 8/2/95. (LOMR 04/17/00) 100YR FLOOD ELEVATION = 458.00
 - ON-SITE LIGHT STANDARDS SHALL NOT EXCEED 16 FEET IN HEIGHT. ON-SITE LIGHTS SHALL BE POSITIONED NOT TO CAST DIRECTLY ON ADJACENT PROPERTIES. LIGHTING PLAN SHALL BE SUBMITTED UNDER SEPARATE COVER.
 - LIGHTING AND SIGNAGE SHALL BE IN COMPLIANCE WITH THE APPROPRIATE CITY ORDINANCE(S) AND GUIDELINE(S).
 - BE ADVISED, ALL ENERGY AND TELEPHONE DISTRIBUTION LINES SHALL BE INSTALLED UNDERGROUND, EXCEPT THOSE OVERHEAD DISTRIBUTION FEEDER LINES NECESSARY TO SERVE THE SUBDIVISION AND IN LOCATIONS AS APPROVED BY THE CITY.
 - APPROVAL OF THIS PLAN DOES NOT CONSTITUTE APPROVAL OF SIGNAGE. SIGN APPROVAL IS A SEPARATE PROCESS.

I, THE OWNER OF THE PROPERTY SHOWN ON THIS PLAN FOR AND IN CONSIDERATION OF BEING GRANTED A PERMIT TO DEVELOP PROPERTY UNDER THE PROVISIONS OF CHAPTER 1003

155 "N-1" OF THE CITY OF CHESTERFIELD (APPLICABLE SUBSECTION) (PRESENT ZONING)

ORDINANCE NO. 1656, AMENDING ORD. 13,935 DO HEREBY AGREE THAT SAID PROPERTY FROM THE DATE OF RECORDING THIS PLAN SHALL BE DEVELOPED THEREON, UNLESS SAID PLAN IS AMENDED BY THE PLANNING COMMISSION, OR VOIDED OR VACATED BY ORDER OF THE CITY OF CHESTERFIELD COUNCIL.

(SIGNATURE) _____

(NAME TYPED) _____

STATE OF _____

COUNTY OF _____

ON THIS _____ DAY OF _____, 2002, BEFORE ME APPEARED _____ AND AN AUTHORIZED REPRESENTATIVE FOR _____, A MISSOURI, AND THAT SAID INSTRUMENT WAS SIGNED IN BEHALF OF SAID COMPANY, AND SAID _____ ACKNOWLEDGED THE SIGNING OF SAID INSTRUMENT TO BE THE FREE ACT AND DEED OF SAID COMPANY.

IN WITNESS WHEREOF, I HAVE HEREIN SET MY HAND AND AFFIXED MY NOTARIAL SEAL THE DAY AND YEAR LAST ABOVE WRITTEN.

NOTARY PUBLIC _____

PRINT NAME _____

MY COMMISSION EXPIRES: _____

This Site Plan was approved by the City of Chesterfield Planning Commission and duly verified on the _____ day of _____, 2003, by the Chairperson of said Commission, authorizing the recording of this Site Plan pursuant to Chesterfield Ordinance No. 200, as amended, and in accordance with the provisions of the City Clerk.

Tereso J. Price, Director of Planning

Marty DeMay, Deputy City Clerk

SURVEYOR'S CERTIFICATION

This is to certify that Stock & Associates Consulting Engineers, Inc. has prepared this Site Development Section Plan from record survey information only and does not represent a property boundary survey. This Site Development Section Plan is a correct representation of all existing and proposed land divisions.

STOCK AND ASSOCIATES CONSULTING ENGINEERS, INC.
 L.S. No. 222-D

By: DONALD W. TAYLOR, Missouri L.S. No. 2041

M.S.D. BENCHMARK

M.S.D. BENCHMARK #11-59 ELEV.=461.50
 "U" ON BACK OF ROLLED CURB, 10' SOUTH OF CL OF CHESTERFIELD AIRPORT ROAD AND 13' WEST OF CL OF GODDARD AVENUE.

SITE BENCHMARK

TEMPORARY BENCHMARK 1 ELEV.=461.05
 "RAILROAD SPIKE" IN TELEPHONE POLE 75' SOUTH OF CHESTERFIELD AIRPORT ROAD AND BETWEEN SPIRIT DRIVE AND TRADE CENTER DRIVE.

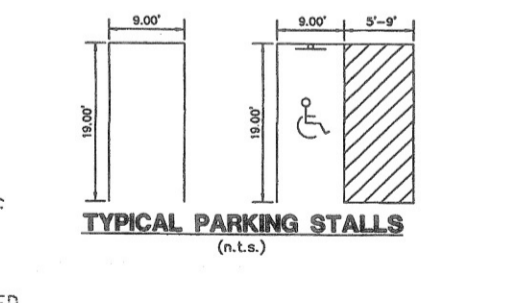
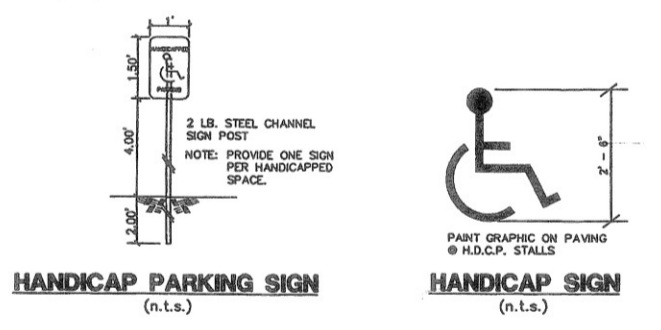
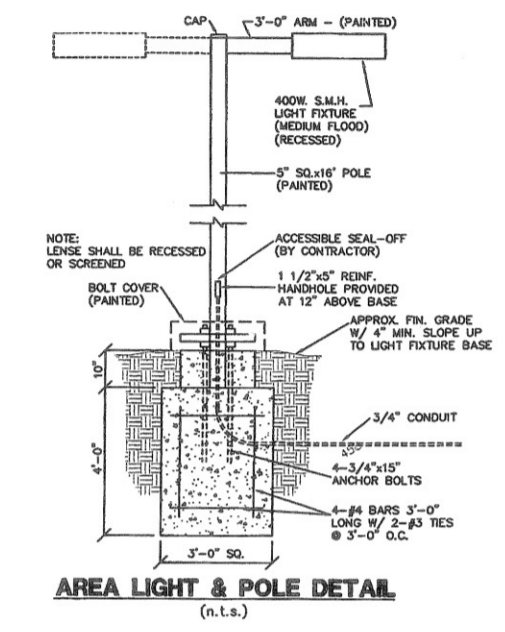
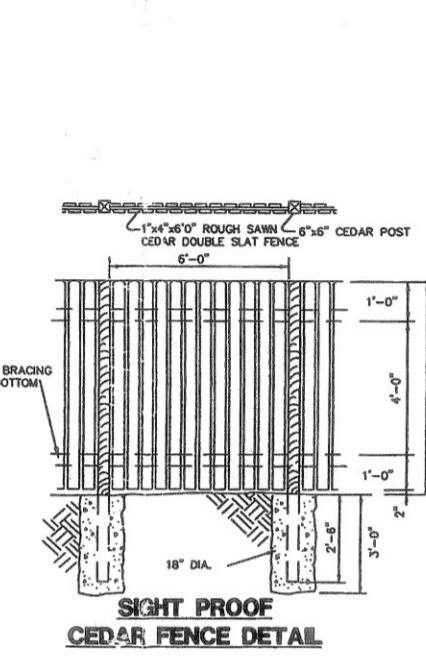
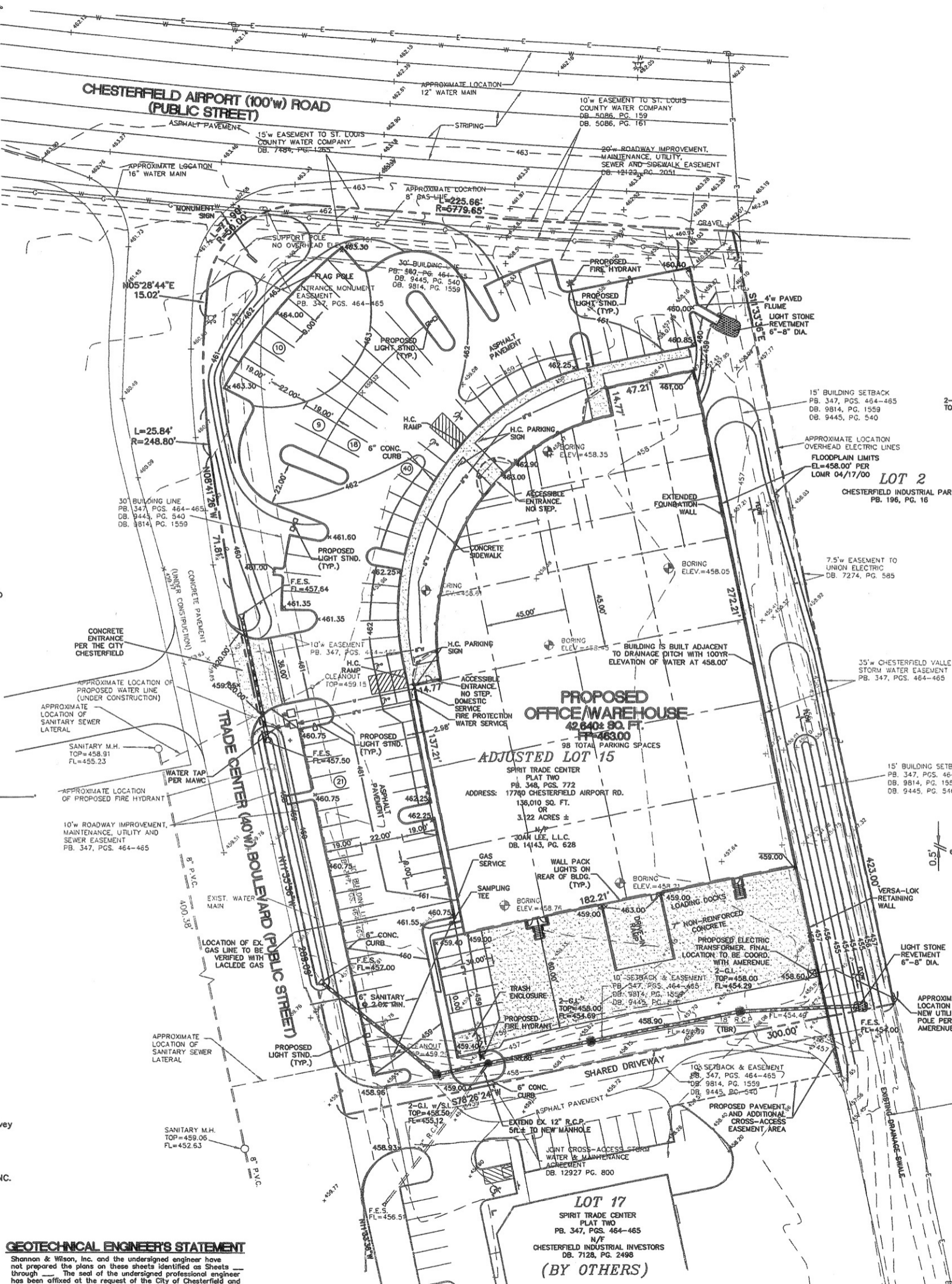

APPROVED
 City of Chesterfield
 Department of Planning
 Date 02/13/03 Signed Tereso Price

Changes:
 1) Relocate trash enclosure
 2) Relocate loading ramp
 3) Lose one parking stall in rear

APPROVED SITE DEVELOPMENT SECTION PLAN
 RECORDED: PB. 350, PG. 567

PREPARED FOR:
 THE WHITE COMPANY
 1750 SOUTH BRENTWOOD BLVD.
 SUITE 301
 ST. LOUIS, MO. 63144
 ATTN: MR. TOM WHITE
 PHONE: (314)-961-4480
 FAX: (314)-961-5903

GEOTECHNICAL ENGINEER'S STATEMENT

Shannon & Wilson, Inc. and the undersigned engineer have not prepared the plans on these sheets identified as Sheets _____ through _____. The seal of the undersigned professional engineer has been affixed at the request of the City of Chesterfield and is a professional opinion to indicate that the undersigned has reviewed the plans and that in his/her opinion the grading and improvements relative to site work as shown on the plans, are compatible with the soil and geologic conditions of the site, as described in the Geotechnical Engineering Report for the project dated _____ and consistent with the recommendations contained in that report.

Thomas J. Abke, P.E.
 E-25569

STATE OF MISSOURI
 REGISTERED PROFESSIONAL ENGINEER
 GEORGE MICHAEL STOCK
 NUMBER E-25116
 2/10/03
 GEORGE M. STOCK E-25116

SECOND AMENDED SITE DEVELOPMENT SECTION PLAN
 AMBASSADOR FLOOR

STOCK & ASSOCIATES CONSULTING ENGINEERS, INC.

425 NORTH NEW BALLAS ROAD
 SUITE 165
 ST. LOUIS, MO. 63141
 PH. (314) 432-8100
 FAX (314) 432-8171
 e-mail: genc@stockassoc.com

DATE: 02/13/03
 G.M.S. 02/13/03
 202-2763
 1 of 2