



VII. B.

690 Chesterfield Pkwy W • Chesterfield MO 63017-0760
Phone: 636-537-4000 • Fax 636-537-4798 • www.chesterfield.mo.us

Planning Commission Staff Report

Project Type:	Site Development Section Plan
Meeting Date:	August 11, 2014
From:	Jessica Henry Project Planner
Location:	158 Long Road
Applicant:	CEDC, on behalf of JLA Development, LLC
Description:	<u>Monarch Center, Lots A & B (Edison Express):</u> A Site Development Section Plan, Landscape Plan, Lighting Plan, Architectural Elevations, and Architect's Statement of Design for a 3.13 acre tract of land zoned "PC" Planned Commercial District located on the northeast corner of the intersection of Long Road and Edison Road.

PROPOSAL SUMMARY

CEDC, on behalf of JLA Development, LLC, has submitted a request for an 11,932 square foot convenience store, gas station, carwash, and fast food restaurant located at the intersection of Long and Edison Roads. The subject site is zoned "PC" Planned Commercial District and is governed under the terms and conditions of City of Chesterfield Ordinance 2753. The exterior building materials will be comprised of brick, stone veneer, glass, aluminum frame, EIFS, and wood plank siding. The proposal includes a mostly flat roof with two raised standing seam metal portions and prefinished metal parapet caps.

This request was reviewed at the July 14, 2014 Planning Commission and at that time a motion to hold Monarch Center, Lots A & B (Edison Express) and to allow the Petitioner to resubmit a revised Site Development Section Plan was passed by a voice vote of 8 to 0. Accordingly, the applicant has revised the Site Development Section Plan and these revisions are the focus of this report. An 11"x17" copy of the previous plan submission has been included in your packets to assist with your review. For additional information and analysis on components of the Site Development Section Plan that are consistent with the previous plan submission, please see Staff's report for the July 14, 2014 Planning Commission meeting.

STAFF ANALYSIS

The subject site is currently zoned "PC" Planned Commercial District under the terms and conditions of City of Chesterfield Ordinance Number 2753. The submittal was reviewed against the requirements of Ordinance Number 2753 and the City of Chesterfield Unified Development Code.

Plan Revisions

The following chart and plan excerpt summarize the plan revisions that have been made since the July 14, 2014 Planning Commission meeting:

Plan Item	Revision
Car wash drive-thru entrance area	Curb cut added to internal shared access drive to remove this traffic from internal site circulation at north end of site.*
Pedestrian plaza/patio area	Outdoor seating island replaced by landscaping; new outdoor seating patio proposed along storefront elevation.
Public art installation area	Expanded to include benches and serve as plaza area.
Car wash drive-thru exit area	Outdoor seating along south building elevation now shown on plan.
Right-in/Right-out Edison Access	Geometry has been revised to extend the island to the north and west.

*The Unified Development Code Development Requirements and Design Standards for off-street parking stipulates that four stacking spaces be provided for each wash bay lane. As this development consists of a single drive-thru car wash tunnel, only four stacking spaces are required. The Applicant has significantly increased the number of stacking spaces provided in the car wash drive-thru lane with the intention of mitigating any queuing issues along the internal drive. Staff is supportive of the provision of additional stacking spaces in this area; however, the third lane consisting of two stacking spaces may be excessive.

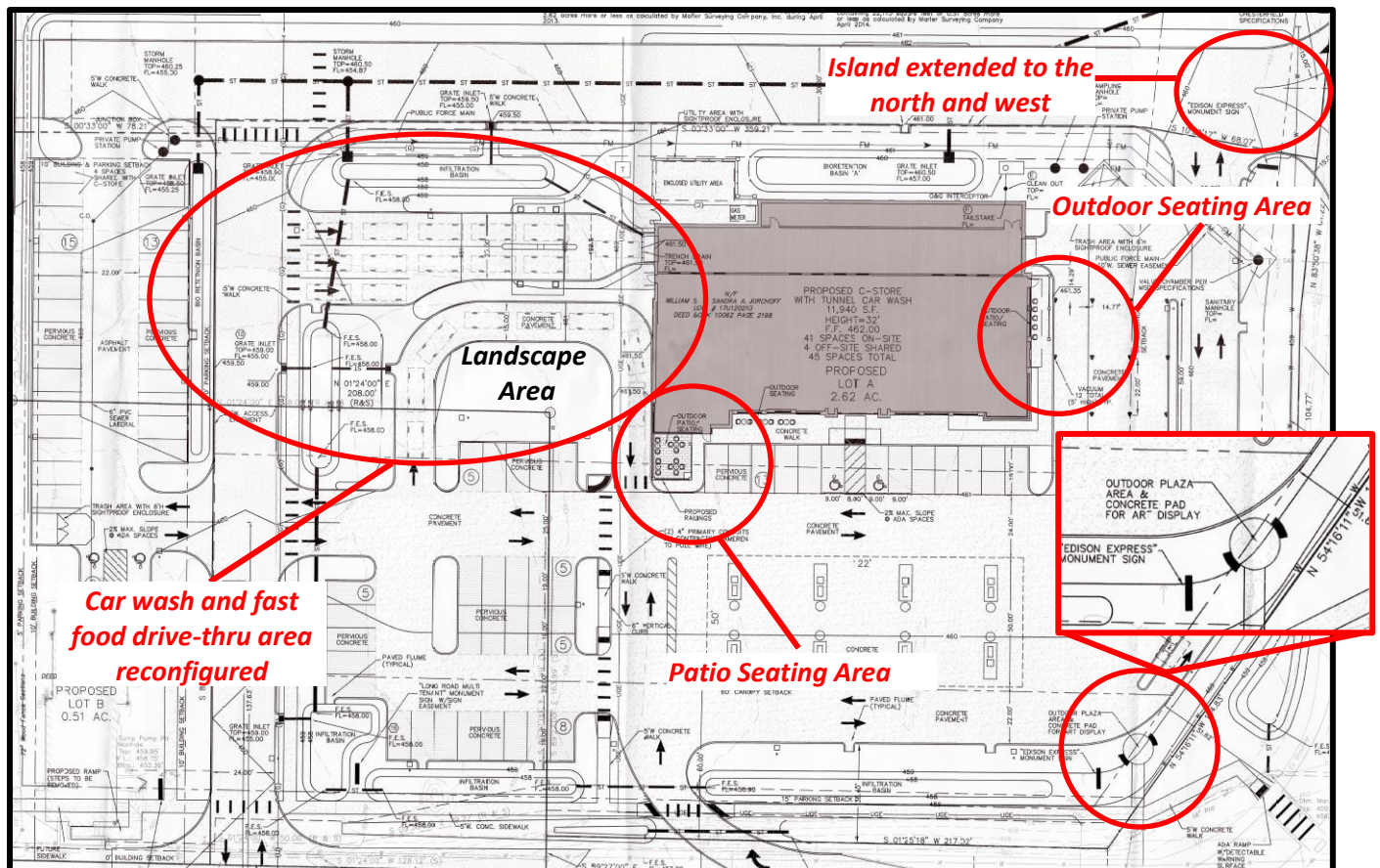

DEPARTMENT INPUT

Staff has reviewed the Site Development Section Plan, Landscape Plan, Tree Preservation Plan, Lighting Plan, Architectural Elevations, and Architect's Statement of Design and has found the application to be in conformance with City of Chesterfield Ordinance 2753, and all other applicable City Code requirements. Staff recommends approval of Site Development Section Plan, Landscape Plan, Tree Preservation Plan, Lighting Plan, Architectural Elevations, and Architect's Statement of Design for the Monarch Center Development.

MOTION

The following options are provided to the Planning Commission for consideration relative to this application:

- 1) "I move to approve (or deny) the Site Development Section Plan, Landscape Plan, Lighting Plan, Architectural Elevations, and Architect's Statement of Design for Monarch Center, Lots A and B (Edison Express).
- 2) "I move to approve the Site Development Section Plan, Landscape Plan, Lighting Plan, Architectural Elevations, and Architect's Statement of Design for Monarch Center, Lots A and B (Edison Express) with the following conditions..." (Conditions may be added, eliminated, altered or modified)

CC: Aimee Nassif, Planning and Development Services Director

Attachments: CEDC Letter
11"x17" Site Development Section Plan (July 14th Planning Commission submission)
Architect's Statement of Design
Architectural Elevations
Lighting Cut-sheets
Site Development Section Plan
Landscape Plan
Lighting Plan
Joint Parking Agreement

CEDC

CIVIL ENGINEERING
DESIGN CONSULTANTS

August 4, 2014

Mr. Chairman and Members of the Commission
Planning Commission
City of Chesterfield
690 Chesterfield Parkway W
Chesterfield, MO 63017

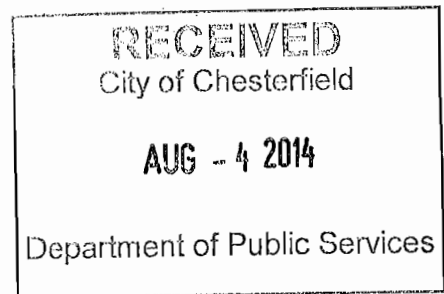

Regarding: Edison Express & Monarch Center
Site Development Section & Concept Plan
158 Long Road
Chesterfield, MO 63005

Dear Members of the Commission:

Pursuant to the Planning Commission meeting on July 14, 2014, the following are changes and clarifications made to the site plan.

1. The entrance lanes to the car wash are relocated to the private internal east/west drive to the north. This allows vehicles access to the car wash without circulating in front of the store and removes the potential confusion on the car wash entry lane and the drive thru restaurant entry lane. In addition, it reduces vehicle and pedestrian conflict points.
2. The drive thru restaurant entry lane is moved north to line up with the drive lane to the west. This also allows for additional stacking in the drive thru lane
3. The geometry of the right-in / right-out drive entrance at Edison Avenue is revised by extending the island to the north and west
4. The outdoor patio area is moved to the northwest front area of the building. In addition, an outdoor patio area is added along the front and south side of the building. An outdoor plaza and sitting area is also added at the southwest corner of the site near the intersection of Long and Edison which will also include an art feature.
5. The customers using the car wash will exit their vehicles just before entering the tunnel. The car will enter the tunnel and immediately exit the tunnel to the dry down area south of the building. The customer will pick up their vehicle from an attendant at the dry down area. As a result, vehicles will not be exiting the car wash tunnel and continue south to the southern east/west internal drive way. In addition, there will not be a conflict with trash pick-up.

Sincerely,
Civil Engineering Design Consultants, Inc.

A handwritten signature in black ink, appearing to read "Brandon A. Harp".

Brandon A. Harp, P.E.
Principal

dial architects

14364 Manchester Road
Manchester Missouri 63011
636 230 0400

December 30, 2013

City of Chesterfield
Department of Planning
690 Chesterfield Parkway West
Chesterfield, Missouri 63017-0760

Members of the Architectural Review Board

Re: Architectural Statement
 Submission for Approval of New Facility for Edison Express
 158 Long Road.

Edison Express Information and Background

The Owner is a current and long time resident of Chesterfield and wishes to build a cutting edge convenience store/carwash to invest in the future of the Chesterfield Valley business community.

General Requirements for Site Design

This project consists of a single-story convenience store with a tunnel carwash. The facility is designed for the convenience store and an additional tenant. The construction site is located on the northeast quadrant of the intersection of Long Road and Edison.

As you can see from the photos in this packet, the rectangular site is treeless and generally flat other than the drainage ditch and is otherwise featureless. The building is strategically located on the site to be compatible with the existing drainage system for the development while maintaining compatibility with neighboring developments.

This project has a 5' wide sidewalk parallel to Long Road to provide pedestrian circulation. The transition from the street to the site effectively utilizes a shared entrance for this site, the existing office building to the north and the proposed future development to the east to help eliminate multiple curb cuts. The parking is located in the front of the building, with added elements to enhance the overall design of the facility and provide safe passage to the entry plaza.

We are not proposing the use of retaining walls on the site at this time.

We are proposing a brick and vinyl plank fence to effectively screen the utility area at the northeast corner of the building.

Landscaping has been designed per city ordinance in a similar fashion to the adjacent developments. Please see attached landscape plan.

General Requirements for Building Design

The owner of this facility, being a long time resident of the City of Chesterfield, has played a major role in the design of this facility and places a high priority on the appearance to enhance the success of the business and to increase the quality of the design in Chesterfield Valley.

The front and side elevations area articulated with brick, glass, reveals, a covered recessed entry and multiple colors of paint and materials. The east side of the building is designed with brick columns and reveals in rhythmically pleasing geometric patterns with accent colors to add depth and shadow lines to the elevations.

As seen on the attached elevations, the building will utilize two earth tone colors, tinted glass and anodized aluminum window frames. The colors, glass and metal items are juxtaposed on the façades of the building to create a very nice overall building design. These include a main building color of a light warm taupe and darker accent color similar in nature.

The building is constructed of brick on all four elevations.

The glass will be an energy efficient, tinted, glass in anodized aluminum frames. As you can see on the attached elevations, we have used the glass as an effective design element in the elevational articulation.

The design is respectful of the surrounding development in general and is harmonious in scale, material, and color. Nearby buildings are also constructed of brick and glass and/or earth tone colors and materials similar to ours. Signage will be applied to the building in a similar fashion as adjacent buildings.

Site lighting is planned with fully shielded, full cut-off optics light standards around the perimeter of the asphalt with wall-mounted, shoebox type fixtures on the east, west and south elevations of the building that will meet City ordinances.

Please see the site development section plan for drainage information.

The roof top units shall be screened by use of unit mounted prefinished metal.

Specific Requirements for the Chesterfield Valley

As stated above we encompass the building with reveals and colors for continuity while highlighting the visible front and sides with glass. The trash receptacle will be screened from public view with brick to coordinate with the building.

The electrical service will be provided by a new transformer located along the north side of the proposed building. All utilities to this building are underground.

I-64/US-40 is to the north of this property and is not readily visible from the property. Automobile parking is west of the building and the service/loading area is on the south side of the building.

Street lighting is included in this project to match the City required street lighting.

It remains our intentions to provide a design that will enhance the local environment while blending with the building types already near the Long Road and Edison Express intersection. The owner is excited about starting his new facility and becoming a business resident in the City of Chesterfield.

Thank you for your assistance.

As required, building materials that will be brought to the ARB meeting will include:

Brick, glass and frame sample, and color samples of the coatings.

End of Architects Statement

LED CANOPY LIGHT - LEGACY™ (CRU)

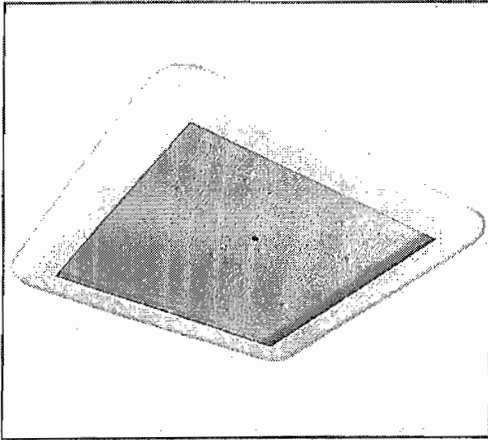

US & Int'l. patents pending.

SMARTTEC™ ENERGY SAVING FEATURES

THERMAL CONTROL - LSI drivers feature integral sensor which reduces drive current, when ambient temperatures exceeds rated temperature.

HOUSING - Low profile, durable die-cast, aluminum construction, providing a reliable weather-tight seal.

LEDS - Features an array of select, mid-power, high brightness, high efficiency LED chips; 5300°K color temperature, 70 CRI (nominal).

DRIVE CURRENT - Choice of Low Wattage (LW), Mid Wattage (MW), Super Saver (SS), High Output (HO), or Very High Output (VHO).

OPTICS / DISTRIBUTION - Symmetrical, which directs light through a clear tempered glass lens, to provide a uniform distribution of light to vertical and horizontal surfaces.

OPTICAL UNIT - Features an ultra-slim 3/4" profile die cast housing, with a flat glass lens. Unit is water-resistant, sealed to an IP67 rating. Integral designed heat sink does not trap dirt and grime, ensuring cool running performance over the life of the fixture.

PRESSURE STABILIZING VENT - Luminaire assembly incorporates a pressure stabilizing vent breather to prevent seal fatigue and failure.

HAZARDOUS LOCATION - Designed for lighter than air fuel applications. Product is suitable for Class 1 Division 2 only when properly installed per LSI installation instructions.

DRIVER - State-of-the-art driver technology superior energy-efficiency and optimum light output. LSI driver components are fully encased in potting for IP65 moisture resistance. Complies with IEC and FCC standards. Surge protected at 10KV.

DRIVER HOUSING - Die cast aluminum, wet location rated driver/electrical enclosure is elevated above canopy deck to prevent water entry, provide easy "knock-out" connection of primary wiring and contributes to attaining the lowest operating temperatures available. Seals to optical housing via one-piece molded silicone gasket.

OPERATING TEMPERATURE - -40°C to 50°C (-40°F to +122°F)

ELECTRICAL - Universal voltage power supply, 120-277 VAC, 50/60 HZ Input. LSI drivers feature two-stage surge protection (including separate surge protection built into electronic driver) meets IEEE C62.41.2-2002, Scenario 1, Location Category C.

FINISH - Standard color is white and is finished with LSI's DuraGrip polyester powder coat process. DuraGrip withstands extreme weather changes without cracking or peeling.

INSTALLATION - One person installation. No additional sealant required. Installs in a 12" or 16" deck pan. Deck penetration consists of a 4" hole, simplifying installation and water sealing. Unit is designed to quickly retrofit into existing Scottsdale (4") hole as well as openings for Encore and Encore Top Access and to reconnect wiring for the SC/ECTA without having to relocate the conduit. Retro panels are available for existing Encores (see back page) as well as kits for recessed and 2x2 installations (see separate spec sheets). Support brackets are provided standard, to prevent sagging of deck.

SHIPPING WEIGHT - 25 pounds (single pack), 50 pounds (double pack).

EXPECTED LIFE - Minimum 60,000 to 100,000 hours depending upon the ambient temperature of the installation location. See LSI web site for specific guidance.

WARRANTY - Limited 5-year warranty.

LISTING - UL and ETL listed to UL 1598, UL 8750 and other U.S. and International safety standards. Suitable for wet locations.

PHOTOMETRICS - Applications layouts are available upon request. Contact LSI Petroleum Lighting or petroleum.apps@lsi-industries.com

LED lighting facts
A Program of the U.S. DOE

Light Output (Lumens)	16997		
Watts	148.9		
Lumens per Watt (Efficacy)	114		
Color Accuracy Color Rendering Index (CRI)	74		
Light Color Correlated Color Temperature (CCT)	5037 (Daylight)		
Warm White	Bright White	Daylight	
2700K	3000K	4500K	6500K
Warranty**		Yes	

All results, except LED Lumen Maintenance, are according to IESNA LM-79-2008: Approved Method for the Electrical and Photometric Testing of Solid-State Lighting. The U.S. Department of Energy (DOE) verifies product test data and results.

** See www.lightingfacts.com/products for details.

Registration Number: KGCN-NZWHD8 (01/2/2013)
Model Number: CRU SC LED HO CW UE
Type: Canopy light

Class 1, Division 2 – Standard on HO, SS, MW & LW only

T5 Temperature Classification – The surface temperature of this product will not rise above 100°C., within a 40°C ambient.

Gas Groups A,B,C, and D – Group A: Acetylene / Group B: Hydrogen / Group C: Propane and Ethylene / Group D: Benzene, Butane, Methane & Propane.

This product, or selected versions of this product, meet the standards listed below. Please consult factory for your specific requirements.



IP67



CRU-SC-LED-LW-CW-UE



Project Name _____ Fixture Type **A**
Catalog # _____

08/23/13

© 2013 LSI INDUSTRIES, INC.

LED CANOPY LIGHT - LEGACY™ (CRU)



LUMINAIRE ORDERING INFORMATION

TYPICAL ORDER EXAMPLE: **CRU SC LED SS CW UE WHT**

Prefix	Distribution	Light Source	Drive Current	Color Temperature	Input Voltage	Finish	Options
CRU	SC - Standard Symmetric	LED	LW - Low Watt MW - Mid Wattage SS - Super Saver HO - High Output VHO - Very High Output	CW - Cool White	UE - Universal Voltage (120-277V) 347-347V ¹	WHT - White BRZ - Bronze BLK - Black	2L - Bi-Level Switching ²

FOOTNOTES:

- 1- 347V only available in HO drive current.
- 2- Bi-Level available on "HO" drive current only.

ACCESSORY ORDERING INFORMATION (Accessories are field installed)

Description	Order Number	Description	Order Number
Retrofit Panels - EC / ECTA / SCF to CRU, for 16" Deck Panel	525946	Kit - Hole Plugs and Silicone (enough for 25 retrofits) ¹	1320540
Retrofit Panels - ECTA / SCF to CRU, for 12" Deck Panel	530281	CRU FKL - Flange Kit ²	537530WHT
Retrofit 2x2 Cover Panel Blank (no holes)	357282	1- Consists of (25) 7/8" hole plugs and (1) 10.3 oz tube of RTV	
Retrofit RIC Cover Panel Blank (no holes)	354702	2- Flange Kit used to mount CRU in double deck applications	

DIMENSIONS

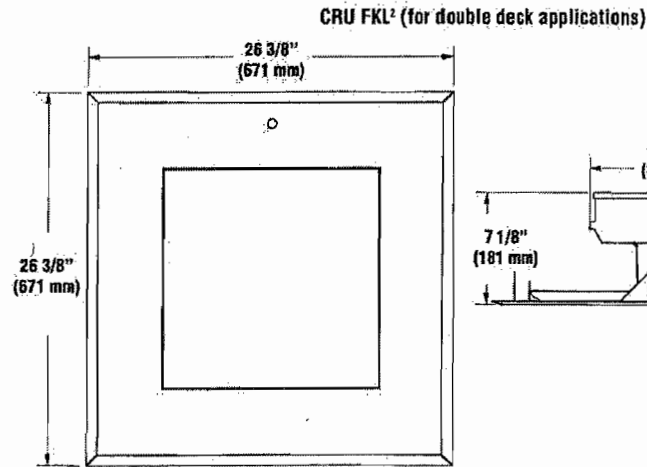
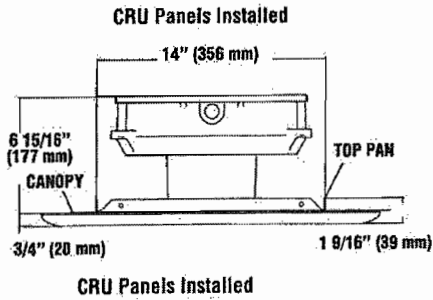
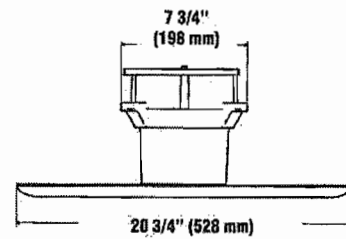
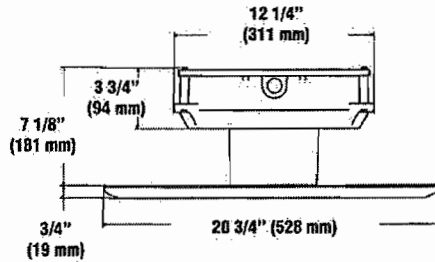
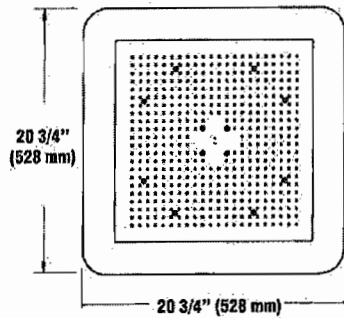

LIGHT OUTPUT - CRU

	Lumens	Watts	LPW	
Cool White	LW - Low Watt	8,438	76	111
	MW - Mid Watt	11,656	103	113
	SS - Super Saver	13,638	129	106
	HO - High Output	17,001	149	114
	VHO - Very High Output	20,997	192	109

Features

- Integrated energy-saving LED technology
- High CRI for rendering architectural highlights and decor
- Widespread downlight distribution with cut-off
- Architectural aluminum construction, sealed and gasketed for weatherproofing and durability
- Available in a variety of popular finishes to complement most commercial environments
- Cool operation for extended lamp and component life
- Easy to install and maintain; easy to clean and re-lamp

Applications

The P6W Downlight Cylinder is ideal for producing a grazing effect on textured finishes, for an interesting effect wherever it is used. It is ideal for aesthetic illumination of inner and outer walls, facades, entrances, and anywhere near-wall illumination or a grazing effect is desired.

Enclosure

The durable, die-cast aluminum enclosure protects the lamp and internal components. With a simple, aesthetic design, the shape and finishes blend with most corporate environments to complement the existing architecture.

Reflector

An internal reflector projects light in the downward direction, with cut-off. The high grade, spun aluminum reflector is highly specular to make the most use of the lumen output. Calculated placement of each type of lamp ensures that light escapes the aperture in a controlled pattern.

Diffuser

The optional diffuser is a clear, tempered glass lens, sealed and gasketed to the enclosure. This is necessary to obtain the IP23 for outdoor applications. An optional baffle is available for concentrating the beam.

Lamp

The P6W Downlight Cylinder is designed to operate with LED (20W max.), compact fluorescent (42W max.), metal halide (50W max.), and incandescent lamps (100W max.), for design and application flexibility. The LED source is capable of producing remarkable spectral characteristics, with CRI of 94% and CCT of 3,368°K, excellent for rendering highlights and foliage.

Socket

All sockets used are compatible with other components in the supplied system. Overall, production is in compliance with North American and European electrical standards; see Compliances.

Ballasts

Electronic compact fluorescent and pulse-start metal halide ballasts used with the P6W Downlight Cylinder share many attributes that contribute to the quality of light, energy savings and safety:

- Virtual flicker-free operation
- High ballast factor of 1.0 for maximum lumen maintenance
- High power factor greater than 90%
- Low THD: CF < 10%; MH < 15%
- Sound rated "A" for the most quiet operation
- EOL protection switches output OFF on lamp burnout
- Environmentally friendly, containing no PCB's
- Color-coded leads for easy installation

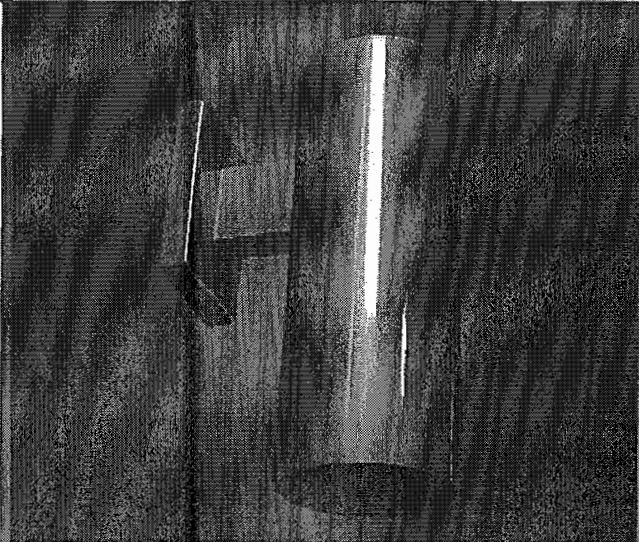

Dimensions

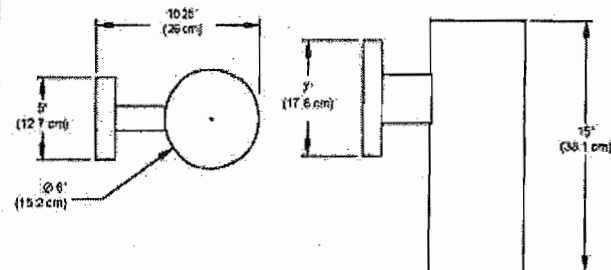

- Manufactured to ISO9002 Quality System Standards
- CF ballasts are also equipped with a RFI circuit to eliminate any electromagnetic interference. Dimming ballasts and emergency ballasts are optional.

LED Driver

The LED source is controlled by an advanced electronic driver, for cool, flicker-free operation, and energy savings. Built from quality components, the driver delivers consistent power and extends LED lamp life. The integral mount is standard.

LED Dimmer

The optional LED dimmer can be installed into a standard switchbox. It controls the intensity of the light output over the upper 90% of the range (10% min. to 100% max.). Integrated pulse width modulation (PWM) technology ensures a consistent color temperature (CCT) when making adjustments, for no color shifts or blurs. You can adjust the amount of light while maintaining the same quality.

Mounting

The mounting canopy is formed of high-grade aluminum. Mount on a flat surface, directly over a standard 4" electrical junction box with 3-1/2" holes center-to-center, in the vertical position.

Finishes

The P6W Downlight Cylinder is finished with a durable polyester powder-coat. More powder-coated base finishes, and RAL colors are available. See the TMS Standard Color Chart.

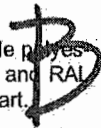

Product Key

P6W	-	LED10	-	120	-	F##	-	
		1		2		3		4

1. Lamp

- A IN100W
- B CF26W PL-T
- C CF32W PL-T
- D CF42W PL-T
- E MH50W ED-17
- F 15W LED
- G 20W LED

2. Voltage

- 1 120V
- 2 277V
- 3 347V (consult TMS)
- 4 220 to 230V

3. Finish

- F05 White
- F15 Matte Black
- F16 Gloss Black
- F18 Satin Aluminum
- F21 Architectural Bronze
- F31 Silver Metallic
- F## Other TMS Finishes (see color chart)
- RL RAL Colors (specify)

4. Options

- DMD Dimming Ballast Advance Mark 10 (CF only)
- DMDL Dimming Ballast Lutron (consult TMS) (CF only)
- BU Emergency Ballast Remote (consult TMS) (CF only)
- BFL6 Anti-glare Baffle
- BGL6 Bottom Glass Lens IP44 (consult TMS)

Custom

TMS Lighting can customize this and many of our standard fixtures. Dimensions, lamp types, and colors could be modified to suit your lighting quality and architectural requirements.

Project: _____
 Type: FIXTURE TYPE B
 Quantity: _____
 Notes: _____



Specifications are subject to change without notice.

Photometric Data

Indoor Classification

CIE Type: Direct
 Spacing Criterion (varies with lamp type)
 0 - 180°: 2.02
 90° - 270°: 2.02
 Diagonal: 1.90

Outdoor Classification

IES Classification: Type VS
 Longitudinal Classification: Very Short
 Cut-off Classification: Cut-off

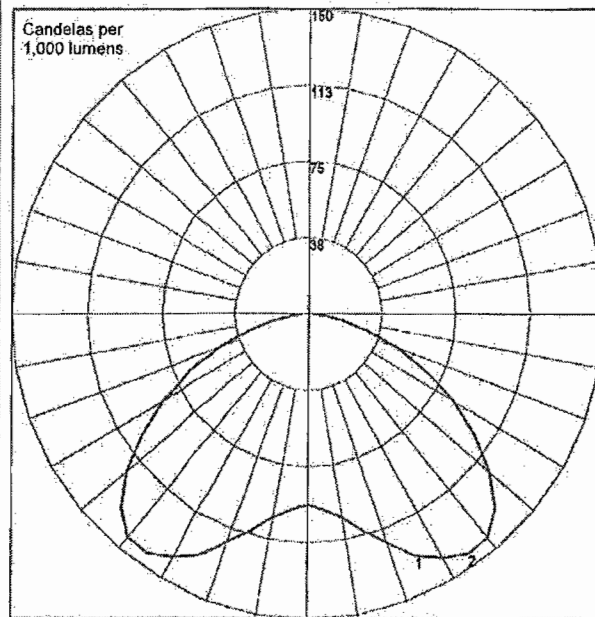

Vertical Plane @ 0°H : _____ (above)
 Vertical Plane @ 90°H : _____ (below)
 Angle of Max. Intensity : 0H 35V

Warranty

TMS Lighting covers this product by a limited warranty for a period of three (3) years from the date of purchase, and lamps are covered by warranty for the period of lamp life specified by the manufacturer. This warranty is effective only when the products are used within the parameters of the recommended operating environment. Install in areas where the ambient temperature does not exceed 50°C/122°F.

Compliances

The P6W Downlight is UL and USTC listed, complies with the Consultants Europe directives, and rated IP23 (with bottom glass lens), for indoor and outdoor applications.

TMS Lighting Inc.
 247A Summerlea Road
 Brampton, Ontario
 Canada L6T 4E1

North America (905) 793-1174
 Toll-free (866) 793-1174
 Fax (905) 793-1175

UK & Europe 44-1474-77-854
 44-1474-77-857
 Fax 44-1474-77-997

Web Site: tmslighting.com

LED AREA LIGHTS - PATRIOT® SMALL (XPTS3)



US patent 7828456, 7952293, 8002428, 8177386 and CAN 2736757 and MX patent 29631 and ISRL 49679 and AUS 2008312668 and US & Int'l. patents pending

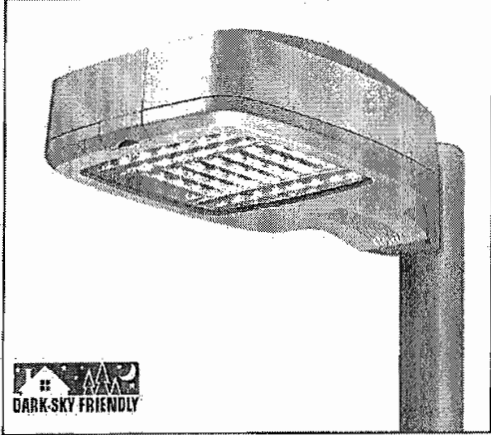

SMARTTEC™ THERMAL CONTROL - Sensors in the driver enclosure reduce driver current when ambient temperatures exceed 50°C. Current is lowered in imperceptible 5% increments every 5 minutes until safe temperature is reached.

EXPECTED LIFE - Minimum 60,000 hours to 100,000 hours depending upon the ambient temperature of the installation location. See LSI web site for specific guidance.

LEDS - Select high-brightness LEDs in Cool White (5800°K nominal) or Neutral White (4000°K nominal) color temperature. 70 CRI (nominal)

DISTRIBUTION/PERFORMANCE - Types 2, 3, FT and 5. Exceptional uniformity creates bright environment at lower light levels. Improved backlight cutoff minimizes light trespass.

HOUSING - One-piece, die-cast aluminum in a multi-radiused, rectangular shape with mounting arm cast in as an integral part of the housing. All hardware is stainless steel or electro-zinc plated steel.

OPTICAL UNIT - Clear tempered optical grade flat glass lens sealed to die-cast aluminum door assembly. Secures to housing with stainless steel hinge bracket. Integral over-center latch allows easy tool-less access to driver. Optic provided with catch mechanism that limits door swing. One-piece extruded silicone gasket seals optical assembly against the housing.

MOUNTING - Use with 5" traditional drilling pattern. Integral cast mounting arm is flat for square pole applications. Use round pole adaptor (RPPC) to mount to round poles. RPPC must be ordered separately. Extruded 6" arm extension is available (but not required).

ELECTRICAL - Two-stage surge protection (including separate surge protection built into electronic driver) meets IEEE C62.41.2-2002, Location Category C. Available with universal voltage power supply 120-277VAC (UE-50-60Hz input) and 347-480VAC. Optional button-type photocells (PCI) are available in 120, 208, 240, 277 or 347 volt (supply voltage must be specified). Fixture watts (nominal): LW - 54, SS - 75.

DRIVER - Available in LW (low wattage) and SS (super saver) drive currents. (Drive currents are factory programmed.) State-of-the-art driver technology designed specifically for LSI LED light sources provides unsurpassed system efficiency. Components are fully encased in potting material for IP65 moisture resistance. Driver complies with requirements of FCC title 47CFR Part 15, Class A and B; Part 18, Class A.

OPERATING TEMPERATURE - -40°C to +50°C (-40°F to +122°F)

FINISH - Fixtures are finished with LSI's DuraGrip® polyester powder coat finishing process. The DuraGrip finish withstands extreme weather changes without cracking or peeling, and is guaranteed for five full years. Standard colors include bronze, black, platinum plus, graphite, satin verde green, metallic silver and white. Meets requirements of ASTM B117 1000-hour salt fog and ASTM G155 1000-hour Xenon Arc UV tests (supersedes G53-UVB313).

WARRANTY - LSI LED fixtures carry a limited 5-year warranty.

PHOTOMETRICS - Application layouts are available upon request. Contact LSI Applications Group at lighting.apps@lsi-industries.com

SHIPPING WEIGHT - 30 lbs./13.6Kg

LISTING - ETL listed to U.S. and Canadian safety standards. Suitable for wet locations.

LIGHT OUTPUT - XPTS3						
		# of LEDs	Lumens (Nominal)			
			Type 2	Type 3	Type FT	Type 5
Cool White	LW	63	4300	4100	4500	3300
	SS	63	5400	5100	5600	4200
Neutral White	LW	63	3700	3600	4000	2900
	SS	63	4900	4900	5100	3900

This product, or selected versions of this product, meet the standards listed below. Please consult factory for your specific requirements.



ARRA IP65 Funding Recipient

XPTS3-FT-LED-63-LW-CW-UE

Also available in traditional light sources

C



Project Name _____ Fixture Type _____
 Catalog # _____

10/28/13
 © 2013
 LSI INDUSTRIES INC.

LED AREA LIGHTS - PATRIOT® SMALL (XPTS3)



LUMINAIRE ORDERING INFORMATION

TYPICAL ORDER EXAMPLE: **XPTS3 FT LED 63 SS CW UE WHT PCI120**

Prefix	Distribution	Light Source	# of LEDs	Drive Current	Color Temperature	Input Voltage	Finish	Options
XPTS3 - LED Patriot Small	2 - Type II 3 - Type III FT - Forward Throw 6 - Type V	LED	63	CG - Super Cover LW - Low Watt	CW - Cool White NW - Neutral White	UE - Universal Voltage (120-277) 347-480	BLK - Black BRZ - Bronze GPT - Graphite MSV - Metallic Silver PLP - Platinum Plus SVG - Satin Verde Green WHT - White	PCI120 - 120V Button-Type Photocell PCI208-277 - 208-277V Button-Type Photocell PCI347 - 347V Button-Type Photocell TB - Terminal Block

LUMINAIRE EPA CHART - XPTS3

	Single	1.1
	D180°	2.1
	D90°	1.6
	T90°	2.7
	TN120°	2.8
	Q90°	3.2

Note: House Side Shield adds to fixture EPA. Consult Factory.

ACCESSORY ORDERING INFORMATION (Accessories are field installed)

Description	Order Number	Description	Order Number
RPPC - Round Pole Plate	141940CLR	XPTS3 HSS - House Side Shield Type 2, 3, FT	516850BLK++
FK120 - Single Fusing	FK120+	XPTS3 PLS - Polycarbonate Shield	263016
FK277 - Single Fusing	FK277+	BKS-BO-PTS-WM-*CLR - Wall Mount Plate	263230CLR
DFK208, 240 - Double Fusing	DFK208,240+	BKA-BO-PTS-EC-6-CLR - Extension Arm	263228CLR
DFK480 - Double Fusing	DFK480+	BKA-BO-RA-8-CLR - Radius Arm	189010CLR
FK347 - Single Fusing	FK347+	BKU-BO-S-19-CLR - Upsweep Bracket for Round and Square Poles	144191CLR

NOTES: +Fusing must be located in the hand hole of pole. ++Black only.

DIMENSIONS

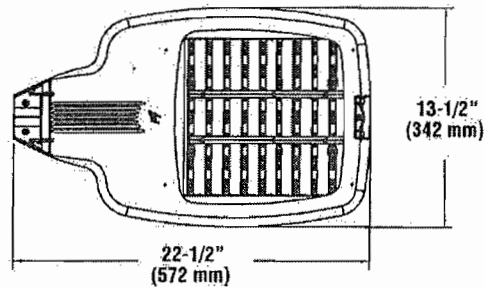
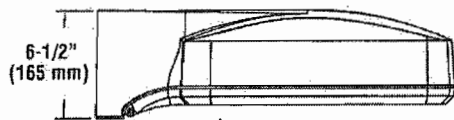

House Side Shield (HSS)
Rear Mounted (516850 BLK)

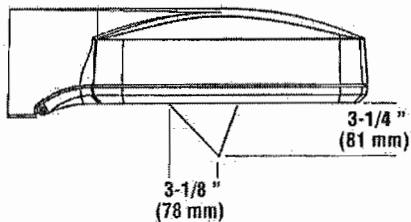

LED PATRIOT WALL SCNCE (XPWS3)

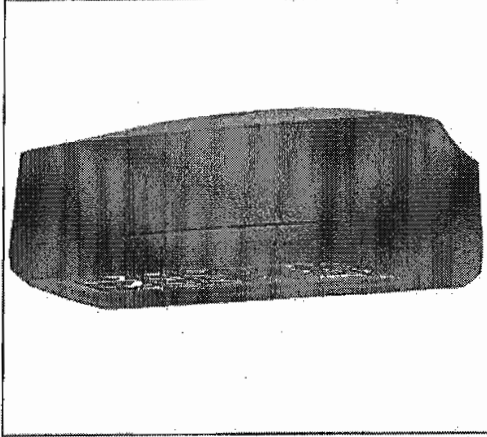

US patents 0562491 & 7828456 and US & Int'l. patents pending

SMARTTEC™ ENERGY SAVING FEATURES:

THERMAL CONTROL - Sensors in both optical unit and driver enclosure reduce drive current when ambient temperatures exceed 50°C. Current is lowered in imperceptible 5% increments every 5 minutes until safe operating temperature is reached.

OCCUPANCY SENSING - Integral sensor (optional) detects movement and activates switching of luminaire to 30% power when no presence is detected. Smart dim slowly lowers light level over a 10-second period.

LEDs - Available with 28 or 48 select high-brightness LED's in Cool White (5300°K nominal) or Neutral White (4200°K nominal) color temperature, 70 CRI (nominal).

DRIVER CURRENT OPTIONS - Choose from two drive current levels; 350mA and 450mA (Drive currents are factory programmed).

OPTICS/DISTRIBUTIONS - Ultra-high efficiency reflectors provide three distributions. Choose from Wide Throw (WT), Forward Throw (FT) or Wall Wash (WW).

OPTICAL UNIT - Clear tempered optical-grade flat glass lens sealed to the die-cast aluminum optic housing creates an IP65 rated unit. Pressure stabilizing breather allows super-tight protection while preventing cycling from building up internal pressures and vacuums that can stress optical unit seals.

DRIVER - Components are fully encased in potting material for IP68 moisture resistance. Driver complies with IEC and FCC standards. Driver can be easily accessed and removed.

ELECTRICAL - Two-stage surge protection (including separate surge protection built into electronic driver) meets IEEE C62.41.2-2002, Scenario 1, Location Category C. Available with universal voltage power supply 120-277VAC (50/60Hz input), 347VAC and 480VAC.

OPTIONAL INTEGRAL MOTION SENSOR - Passive infrared motion sensor activates switching of luminaire light levels. High level light is activated when passersby enter target zone and increased to full bright in 1-2 seconds. Low light level (30% of maximum drive current) is activated when target zone is absent of motion activity for 5 minutes and is gradually ramped down (10 seconds) to low level. Sensor detection range 110° horizontal x 93° vertical x 10 meters maximum distance.

EMERGENCY OPTIONS - Integral emergency battery-back-up options are available. BB option operates in 0°C to 60°C ambient temperature and CWBB operates in -20°C to 60°C ambient temperature. When primary AC power failure occurs, both options operate 10 LEDs for a minimum of 90 minutes. EMR2 option for two external 12 volt circuits for use with 35 watt Halogen lamps (provided) is available.

HOUSING - One-piece die-cast aluminum housing is smoothly contoured rectangular shape. Mounting hardware is stainless steel or electro-zinc plated steel. Housing and optical unit are sealed with extruded silicone gasket; supply conductors with molded EPDM bushing.

OPERATING TEMPERATURE - -40°C to +50°C (-40°F to +122°F).

WALL MOUNTING - Galvanized-steel universal wall mounting plate easily mounts directly to 4" octagonal or square junction box. EPDM gasket is supplied to be installed between mounting plate and junction box, sealing junction box from entrance of water. Universal plate permits fixture to be mounted in uplighting (indoor only) or downlighting position.

POLE MOUNTING - XPMA option adds a clean look closure to the back of the housing and includes bracket to allow fixture to be pole-mounted.

FINISH - Fixtures are finished with LSI's DuraGrip® polyester powder coat finish process. The DuraGrip finish withstands extreme weather changes without cracking and peeling, and is guaranteed for five full years. See ordering guide for available standard colors.

SHIPPING WEIGHT (in carton) - 25 lbs. (11 kg)

EXPECTED LIFE - Minimum 60,000 hours to 100,000 hours depending upon the ambient temperature of the installation location. See LSI website for specific guidance.

WARRANTY - Limited 5-year warranty.

PHOTOMETRICS - Application layouts are available. Contact LSI Applications at lighting_apps@lsi-industries.com

LISTING - ETL listed to ANSI/UL1598, UL8750 and other U.S. and international safety standards. Suitable for wet locations in downlight position. Optional Class 1 Division 2 (groups A, B, C & D) hazardous location rating is available. (Select HL option)

lighting facts®

A Program of the U.S. DOE

Light Output (Lumens) **4020**
Watts **53**
Lumens per Watt (Efficacy) **76**

Color Accuracy **67**
Color Rendering Index (CRI)



All results are according to IESNA LM-79-2008: Approved Method for the Electrical and Photometric Testing of Solid-State Lighting. The U.S. Department of Energy (DOE) verifies product test data and results.

Visit www.lightingfacts.com for the Label Reference Guide.

Registration Number: KGGN-V1H7ZA
Model Number: XPWS3 FT LED 48 350 CW UE
Type: Outdoor wall pack

LIGHT OUTPUT - XPWS3

Milliamps	# of LEDs	Distribution/Lumens (Nominal)				Watts	
		Type FT	Type WT	Type WW			
Cool White	28	2300	2280	2580	33		
	48	4820	4940	4180	53		
	28	2820	2740	3010	44		
450 mA	48	4810	4600	4970	68		
	Neutral White	28	2260	2190	2420	32	
		48	4740	4570	4760	52	
28		2660	2600	2850	44		
450 mA	48	4420	4100	4450	67		

This product, or selected versions of this product, meet the standards listed below. Please consult factory for your specific requirements.

IP65



ARRA
Funding Compliant

ROHS
COMPLIANT

Intertek
Suitable for wet locations
(downlight only)

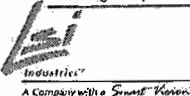

Project Name

Fixture Type

Catalog #

XPWS3-WW-LED-28-350-CW-UE

01/27/12

© 2012
LSI INDUSTRIES INC.

LED PATRIOT WALL SCONCE (XPWS3)



LUMINAIRE ORDERING INFORMATION

TYPICAL ORDER EXAMPLE: **XPWS3 FT LED 48 450 CW UE WHT BB**

Prefix	Distribution	Light Source	# of LEDs	Drive Current	Color Temperature	Input Voltage	Finish	Options
XPWS3 - LED Patriot Wall Sconce	WT - Wide Throw FT - Forward Throw WW - Wall Wash	LED	28 48	350 - 350mA 450 - 450mA	CW - Cool White NW - Neutral White	UE - Universal Voltage (120-277) 347-480	BLK - Black BRZ - Bronze GPT - Graphite MSV - Metallic Silver PLP - Platinum Plus SVG - Satin Verde Green WHT - White	BB - Battery Back-up ¹ CWBB - Cold Weather Battery Back-up ¹ IMS - Integral Motion Sensor TP - Tamper Proof EMR2 - Two Emergency 12V Circuit Provisions with (2) 35 Watt Halogen Lamps ² PCI 120 - Button Type Photocell PCI 208 - Button Type Photocell PCI 240 - Button Type Photocell PCI 277 - Button Type Photocell PCI 347 - Button Type Photocell HL - Class1, Division2, Hazardous Location Rating, ETL listed to UL844 ³ XPMA - Pole Mounting Adaptor w/fixture backplate for use with square poles ⁴ XPMB - Pole Mounting Adaptor w/fixture backplate for use with round poles ⁴

ACCESSORY ORDERING INFORMATION (Accessories are field installed)	
Description	Order Number
XPWS3 Polycarbonate Shield	244657
XPWS3 SW BLK - Surface Wiring Box (Available in black only)	356915BLK
SCDB - Tamper-proof Screwdriver Bit	420908

FOOTNOTES:

- 1- Available with UE voltage only.
- 2 - Utilizes GZ4 sockets. 12 volt separate circuits required. Not available with battery back-up, photocell option, HL, XPMA or XPMB options.
- 3 - Not available with battery backup, photocell or EMR2 option.
- 4 - Not available with EMR2 option. Designed with 3" reduced drilling pattern. For S or D180 mounting configuration only.

DIMENSIONS

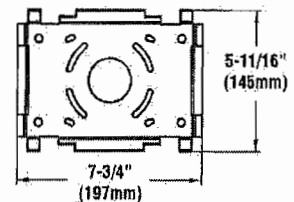
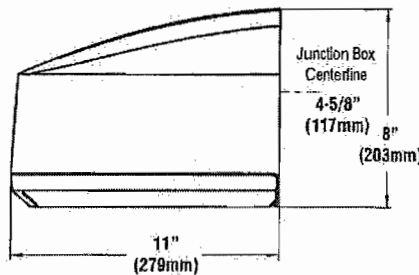
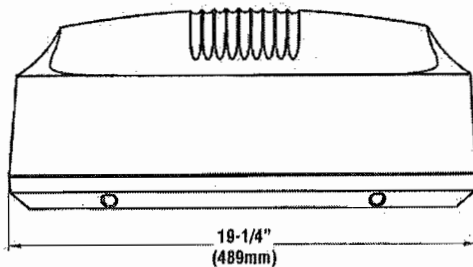

Universal Mounting Plate

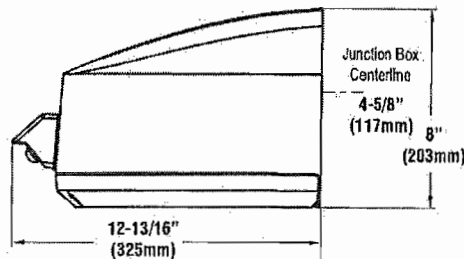
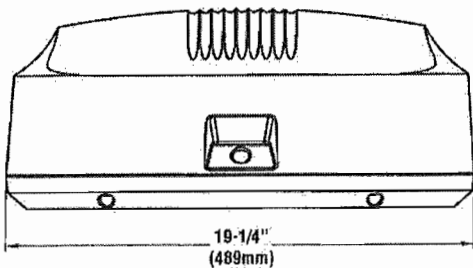

Shown with IMS Option

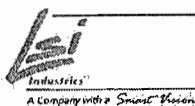

Project Name _____ Fixture Type _____
 Catalog # _____

D

01/27/12

© 2012
 LSI INDUSTRIES INC.

LED AREA LIGHTS - PATRIOT® SMALL (XPTS3)

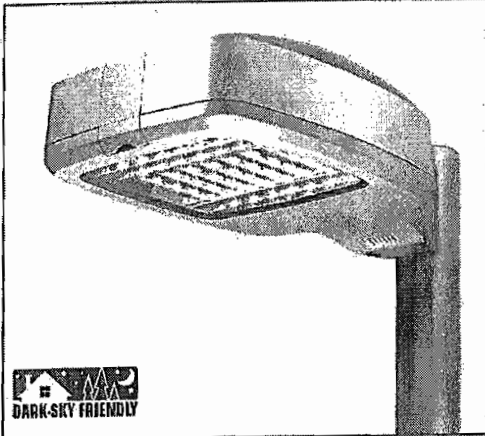

US patent 7828456, 7952293, 8002428, 8177386 and CAN 2736757 and MX patent 29631 and ISRL 49679 and AUS 2008312668 and US & Int'l. patents pending

SMARTTEC™ THERMAL CONTROL - Sensors in the driver enclosure reduce driver current when ambient temperatures exceed 50°C. Current is lowered in imperceptible 5% increments every 5 minutes until safe temperature is reached.

EXPECTED LIFE - Minimum 60,000 hours to 100,000 hours depending upon the ambient temperature of the installation location. See LSI web site for specific guidance.

LEDS - Select high-brightness LEDs in Cool White (5800°K nominal) or Neutral White (4000°K nominal) color temperature. 70 CRI (nominal)

DISTRIBUTION/PERFORMANCE - Types 2, 3, FT and 5. Exceptional uniformity creates bright environment at lower light levels. Improved backlight cutoff minimizes light trespass.

HOUSING - One-piece, die-cast aluminum in a multi-radiused, rectangular shape with mounting arm cast in as an integral part of the housing. All hardware is stainless steel or electro-zinc plated steel.

OPTICAL UNIT - Clear tempered optical grade flat glass lens sealed to die-cast aluminum door assembly. Secures to housing with stainless steel hinge bracket. Integral over-center latch allows easy tool-less access to driver. Optic provided with catch mechanism that limits door swing. One-piece extruded silicone gasket seals optical assembly against the housing.

MOUNTING - Use with 5" traditional drilling pattern. Integral cast mounting arm is flat for square pole applications. Use round pole adaptor (RPPC) to mount to round poles. RPPC must be ordered separately. Extruded 6" arm extension is available (but not required).

ELECTRICAL - Two-stage surge protection (including separate surge protection built into electronic driver) meets IEEE C62.41.2-2002, Location Category C. Available with universal voltage power supply 120-277VAC (UE-50-60Hz input) and 347-480VAC. Optional button-type photocells (PCI) are available in 120, 208, 240, 277 or 347 volt (supply voltage must be specified). Fixture watts (nominal): LW - 54, SS - 75.

DRIVER - Available in LW (low wattage) and SS (super saver) drive currents. (Driver currents are factory programmed.) State-of-the-art driver technology designed specifically for LSI LED light sources provides unsurpassed system efficiency. Components are fully encased in potting material for IP65 moisture resistance. Driver complies with requirements of FCC title 47CFR Part 15, Class A and B; Part 18, Class A.

OPERATING TEMPERATURE - -40°C to +50°C (-40°F to +122°F)

FINISH - Fixtures are finished with LSI's DuraGrip® polyester powder coat finishing process. The DuraGrip finish withstands extreme weather changes without cracking or peeling, and is guaranteed for five full years. Standard colors include bronze, black, platinum plus, graphite, satin verde green, metallic silver and white. Meets requirements of ASTM B117 1000-hour salt fog and ASTM G155 1000-hour Xenon Arc UV tests (supersedes G53-UVB313).

WARRANTY - LSI LED fixtures carry a limited 5-year warranty.

PHOTOMETRICS - Application layouts are available upon request. Contact LSI Applications Group at lighting.apps@lsi-industries.com

SHIPPING WEIGHT - 30 lbs./13.6Kg

LISTING - ETL listed to U.S. and Canadian safety standards. Suitable for wet locations.

LIGHT OUTPUT - XPTS3						
		# of LEDs	Lumens (Nominal)			
			Type 2	Type 3	Type FT	Type 5
Cool White	LW	83	4300	4100	4500	3300
	SS	83	5400	5100	5600	4200
Neutral White	LW	66	3700	3600	4000	2900
	SS	66	4900	5000	5100	3900

This product, or selected versions of this product, meet the standards listed below. Please consult factory for your specific requirements.



ARRA IP65 Funding Compliant

XPTS3-2-LED-63-LW-CW-UE

E

Also available in traditional light sources



Project Name _____ Fixture Type _____
 Catalog # _____

10/28/13
 © 2013
 LSI INDUSTRIES INC.

LED AREA LIGHTS - PATRIOT® SMALL (XPTS3)



LUMINAIRE ORDERING INFORMATION

TYPICAL ORDER EXAMPLE: **XPTS3 FT LED 63 SS CW UE WHT PCI120**

Prefix	Distribution	Light Source	# of LEDs	Drive Current	Color Temperature	Input Voltage	Finish	Options
XPTS3 - LED Patriot Small	2- Type II 3- Type III 4- Forward Throw 5- Type V	LED	63	SS - Super Saver LW - Low Watt	CW - Cool White NW - Neutral White	UE - Universal Voltage (120-277) 347-480	BLK - Black BRZ - Bronze GPT - Graphite MSV - Metallic Silver PLP - Platinum Plus SVG - Satin Verde Green WHT - White	PCI120 - 120V Button-Type Photocell PCI208-277 - 208-277V Button-Type Photocell PCI347 - 347V Button-Type Photocell TB - Terminal Block

LUMINAIRE EPA CHART - XPTS3

Beam Spread	Footcandle at 10' (m)
Single	1.1
D180°	2.1
D90°	1.6
T90°	2.7
TN120°	2.8
Q90°	3.2

Note: House Side Shield adds to fixture EPA. Consult Factory.

ACCESSORY ORDERING INFORMATION (Accessories are field installed)

Description	Order Number	Description	Order Number
RPPC - Round Pole Plate	141940CLR	XPTS3 HSS - House Side Shield Type 2, 3, FT	516850BLK**
FK120 - Single Fusing	FK120*	XPTS3 PLS - Polycarbonate Shield	263016
FK277 - Single Fusing	FK277*	BKS-BO-PTS-WM-CLR - Wall Mount Plate	263230CLR
DFK208, 240 - Double Fusing	DFK208,240*	BKA-BO-PTS-EC-6-CLR - Extension Arm	263228CLR
DFK480 - Double Fusing	DFK480*	BKA-BO-RA-9-CLR - Radius Arm	169010CLR
FK347 - Single Fusing	FK347*	BKLI-BO-S-19-CLR - Upsweep Bracket for Round and Square Poles	144191CLR

NOTES: *Fusing must be located in the hand hole of pole. **Black only.

DIMENSIONS

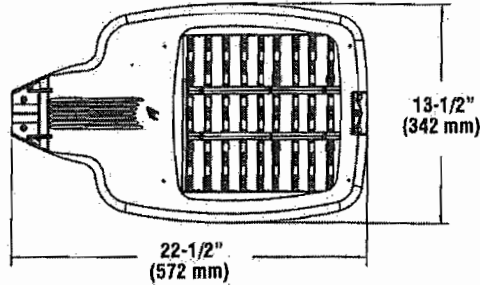
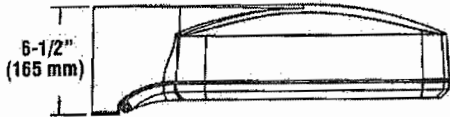

House Side Shield (HSS)
Rear Mounted (516850 BLK)

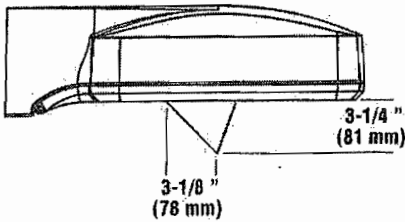

E

LED AREA LIGHTS - PATRIOT® SMALL (XPTS3)

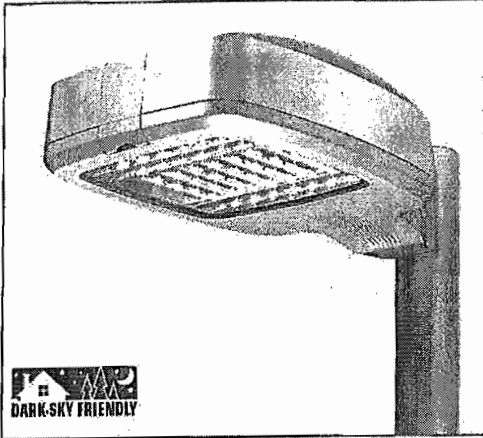

US patent 7828456, 7952293, 8002428, 8177386 and CAN 2736757 and MX patent 29631 and ISRL 49679 and AUS 2008312658 and US & Int'l. patents pending

SMARTTEC™ THERMAL CONTROL - Sensors in the driver enclosure reduce driver current when ambient temperatures exceed 50°C. Current is lowered in imperceptible 5% increments every 5 minutes until safe temperature is reached.

EXPECTED LIFE - Minimum 60,000 hours to 100,000 hours depending upon the ambient temperature of the installation location. See LSI web site for specific guidance.

LEDS - Select high-brightness LEDs in Cool White (5800°K nominal) or Neutral White (4000°K nominal) color temperature. 70 CRI (nominal)

DISTRIBUTION/PERFORMANCE - Types 2, 3, FT and 5. Exceptional uniformity creates bright environment at lower light levels. Improved backlight cutoff minimizes light trespass.

HOUSING - One-piece, die-cast aluminum in a multi-radiused, rectangular shape with mounting arm cast in as an integral part of the housing. All hardware is stainless steel or electro-zinc plated steel.

OPTICAL UNIT - Clear tempered optical grade flat glass lens sealed to die-cast aluminum door assembly. Secures to housing with stainless steel hinge bracket. Integral over-center latch allows easy tool-less access to driver. Optic provided with catch mechanism that limits door swing. One-piece extruded silicone gasket seals optical assembly against the housing.

MOUNTING - Use with 5" traditional drilling pattern. Integral cast mounting arm is flat for square pole applications. Use round pole adaptor (RPPC) to mount to round poles. RPPC must be ordered separately. Extruded 6" arm extension is available (but not required).

ELECTRICAL - Two-stage surge protection (including separate surge protection built into electronic driver) meets IEEE C62.41.2-2002, Location Category C. Available with universal voltage power supply 120-277VAC (UE-50-60Hz input) and 347-480VAC. Optional button-type photocells (PCI) are available in 120, 208, 240, 277 or 347 volt (supply voltage must be specified). Fixture watts (nominal): LW - 54, SS - 75.

DRIVER - Available in LW (low wattage) and SS (super saver) drive currents. (Drive currents are factory programmed.) State-of-the-art driver technology designed specifically for LSI LED light sources provides unsurpassed system efficiency. Components are fully encased in potting material for IP65 moisture resistance. Driver complies with requirements of FCC title 47CFR Part 15, Class A and B; Part 18, Class A.

OPERATING TEMPERATURE - -40°C to +50°C (-40°F to +122°F)

FINISH - Fixtures are finished with LSI's DuraGrip® polyester powder coat finishing process. The DuraGrip finish withstands extreme weather changes without cracking or peeling, and is guaranteed for five full years. Standard colors include bronze, black, platinum plus, graphite, satin verde green, metallic silver and white. Meets requirements of ASTM B117 1000-hour salt fog and ASTM G155 1000-hour Xenon Arc UV tests (supersedes G53-UVB313).

WARRANTY - LSI LED fixtures carry a limited 5-year warranty.

PHOTOMETRICS - Application layouts are available upon request. Contact LSI Applications Group at lighting.apps@lsi-industries.com

SHIPPING WEIGHT - 30 lbs./13.6Kg

LISTING - ETL listed to U.S. and Canadian safety standards. Suitable for wet locations.

LIGHT OUTPUT - XPTS3						
		# of LEDS	Lumens (Nominal)			
			Type 2	Type 3	Type FT	Type 5
Cool White	LW	63	4300	4100	4500	3300
	SS	63	5400	5100	5600	4200
Neutral White	LW	63	3700	3800	4000	2800
	SS	63	4800	5000	5100	3900

This product, or selected versions of this product, meet the standards listed below. Please consult factory for your specific requirements.



XPTS3-5-LED-63-LW-CW-UE

F

Also available in traditional light sources



Project Name _____ Fixture Type _____
 Catalog # _____

10/28/13

© 2013

LSI INDUSTRIES INC.

LED AREA LIGHTS - PATRIOT® SMALL (XPTS3)



LUMINAIRE ORDERING INFORMATION

TYPICAL ORDER EXAMPLE: **XPTS3 FT LED 63 SS CW UE WHT PCI120**

Prefix	Distribution	Light Source	# of LEDs	Drive Current	Color Temperature	Input Voltage	Finish	Options
XPTS3 - LED Patriot Small	2 - Type II 3 - Type III FF - Forward Throw 5 - Type V	LED	63	SS - Super Series LW - Low Watt	CW - Cool White NW - Neutral White	UE - Universal Voltage (120-277) 347-480	BLK - Black BRZ - Bronze GPT - Graphite MSV - Metallic Silver PLP - Platinum Plus SVG - Satin Verde Green WHT - White	PCI120 - 120V Button-Type Photocell PCI208-277 - 208-277V Button-Type Photocell PCI347 - 347V Button-Type Photocell TB - Terminal Block

LUMINAIRE EPA CHART - XPTS3

	Single	1.1
	D180°	2.1
	D90°	1.6
	T90°	2.7
	TN120°	2.8
	Q90°	3.2

Note: House Side Shield adds to fixture EPA. Consult Factory.

ACCESSORY ORDERING INFORMATION (Accessories are field installed)

Description	Order Number	Description	Order Number
RPPC - Round Pole Plate	141940CLR	XPTS3 HSS - House Side Shield Type 2, 3, FT	516850BLK**
FK120 - Single Fusing	FK120*	XPTS3 PLS - Polycarbonate Shield	263016
FK277 - Single Fusing	FK277*	BKS-80-PTS-WM-CLR - Wall Mount Plate	263230CLR
DFK208, 240 - Double Fusing	DFK208, 240*	BKA-80-PTS-EC-6-CLR - Extension Arm	263228CLR
DFK480 - Double Fusing	DFK480*	BKA-80-RA-8-CLR - Radius Arm	169010CLR
FK347 - Single Fusing	FK347*	BKU-80-S-19-CLR - Upsweep Bracket for Round and Square Poles	144191CLR

NOTES: *Fusing must be located in the hand hole of pole. **Black only.

DIMENSIONS

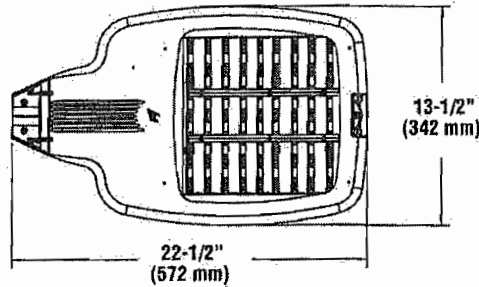
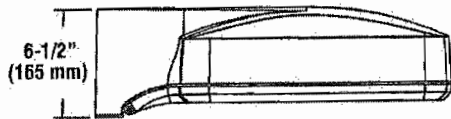

House Side Shield (HSS)
Rear Mounted (516850 BLK)

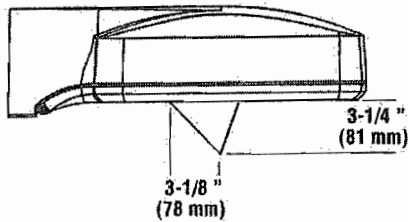

F

LSI ABOLITE® LED ANGLED REFLECTOR (AD)



US patents D598162 & D581585 & D581544 & 7697766 and US & Int'l. patents pending

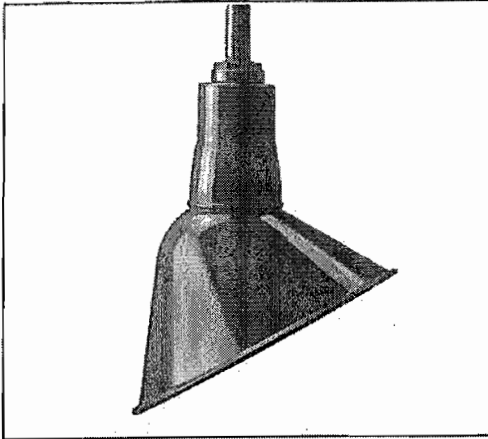

APPLICATIONS - Signage Lighting and Accent Lighting. Interior or Exterior.

PRODUCT HIGHLIGHTS

- **"Green" Energy-Saving** - Reduces greenhouse gas emissions, slashes operating costs, extends life and eliminates costly lamp disposal involving mercury waste.
- **Long Lasting Sparkle** - LED light beam contains no heat, and no UV, which means degradation in color or quality of the product under display is minimized.
- **Dramatically Lower Maintenance Costs** - 60,000-hour LED source extends life 3 to 5 times as compared to conventional HID sources, 30 times incandescent.
- **Integrated Power Supply** - Built into fixture allowing RLM to be connected directly to line voltage.

EXPECTED LIFE - Minimum 60,000 hours to 100,000 hours depending upon the ambient temperature of the installation location.

LEDS - Select high-brightness LEDs in Cool White (5300° K nominal), Neutral White (4000° K nominal), and Warm White (3500° K nominal) color temperature. 70 CRI (nominal) CW. 80 CRI (nominal) NW and WW.

OPTIONAL DIRECTIONAL OPTICS - Allows field adjustment of the light beam for directional illumination of signage.

REFLECTOR - Heavy duty spun galvanized steel construction with polyester powder coat finish.

LIGHT OUTPUT - With an input power of 11 watts: DO - Optional Directional Optics (nominal) - Cool White - 970 lumen, Neutral White - 810 lumens and Warm White - 745 lumens. Symmetric Optics (nominal) - Cool White - 905 lumens, Neutral White - 760 lumens and Warm White - 700 lumens

MOUNTING - Fixed hub tapped for 3/4" NPT conduit. Pre-wired with 96" leads. Not designed for uplight applications.

ELECTRICAL - Integral, surge protected power supply operates on 120-240 VAC (50/60Hz) input; no external power supplies required.

DRIVER - State-of-the-art driver designed specifically for RLM fixtures provides unsurpassed system efficiency. Components are fully encased in potting material for moisture resistance. Driver complies with IEC and FCC standards.

OPERATING TEMPERATURE - -40°C to +50°C (-40°F to +122°F).

FINISH - Available in either architectural textured, high gloss or satin finish.

WARRANTY - LSI LED fixtures carry a limited 5-year warranty.

LISTING - Listed to U.S. and Canadian safety standards. Suitable for wet locations.

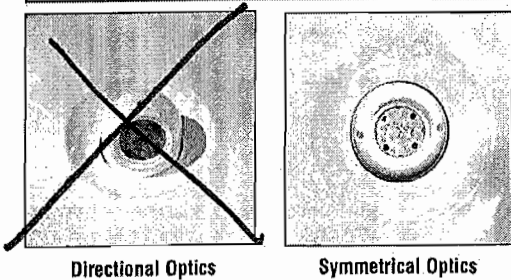

Directional Optics

Symmetrical Optics

DIMENSIONS

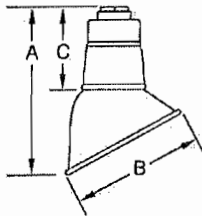

Prefix	Height (A)	Diameter (B)	Neck (C)	Weight (lbs./kg)
AD 100	10" (254mm)	7" (178mm)	5" (127mm)	2.0 (.9kg)
AD 150	11-1/2" (292mm)	9" (229mm)	5-1/4" (133mm)	2.0 (.9kg)
AD 200	13-1/2" (343mm)	11" (279mm)	5-1/2" (140mm)	2.5 (1.1kg)

Also available in traditional light sources

This product, or selected versions of this product, meet the standards listed below. Please consult factory for your specific requirements.



AD 150-10-CW-LED-UE



Project Name _____ Fixture Type G
 Catalog # _____

01/21/14
 © 2014
 LSI INDUSTRIES INC.

LSI ABOLITE® LED ANGLED REFLECTOR (AD)



LUMINAIRE ORDERING INFORMATION

TYPICAL ORDER EXAMPLE: **AD 200 10 CW LED UE MSV LDS96 WL DO**

Prefix	# of LED's	Color Temperature	Light Source	Input Voltage	Reflector Color	Mounting	Options
AD 100 AD 150 AD 200	10	CW - Cool White NW - Neutral White WW - Warm White	LED	120-240 ²	MSV-Metallic Silver GWT-Gloss White GBK-Gloss Black GRD-Gloss Red GPT-Textured Graphite RUS-Textured Rust SCP-Satin Copper STQ-Satin Turquoise SVG-Satin Verde Green	LDS96 WL - Factory prewired leads for use with stem or bracket mounting	DO - Directional Optics

1- Cordsets not available for AD Series.

2- Fixture will not operate on 277VAC (120-240 only).

Description	Order Number
3/4" (19mm) Tap Decorative Box Cover Aligner - Gloss White	BC600 3 GWT
3/4" (19mm) Tap Round Box Cover Aligner - Zinc	BC585 ZINC
3/4" (19mm) Tap Square Box Cover Aligner - Zinc	BC585SQ ZINC

- Standard BC600 finish is Gloss White Powder; other RLM colors available.

Description	Order Number
7" (178mm) Convex Wire Guard - Metallic Silver	COG 7 MSV
9" (229mm) Convex Wire Guard - Metallic Silver	COG 9 MSV
11" (279mm) Convex Wire Guard - Metallic Silver	COG 11 MSV

- Standard finish is Metallic Silver Powder; other RLM colors available.

Description	Order Number
3/4" x 3" (19mm x 76mm) Aluminum Stem - Gloss White	ST 3 3 GWT
3/4" x 6" (19mm x 152mm) Aluminum Stem - Gloss White	ST 6 3 GWT
3/4" x 12" (19mm x .4m) Aluminum Stem - Gloss White	ST 12 3 GWT
3/4" x 18" (19mm x .5m) Aluminum Stem - Gloss White	ST 18 3 GWT
3/4" x 24" (19mm x .6m) Aluminum Stem - Gloss White	ST 24 3 GWT
3/4" x 36" (19mm x .9m) Aluminum Stem - Gloss White	ST 36 3 GWT
3/4" x 48" (19mm x 1.2m) Aluminum Stem - Gloss White	ST 48 3 GWT
3/4" x 60" (19mm x 1.5m) Aluminum Stem - Gloss White	ST 60 3 GWT
3/4" x 72" (19mm x 1.8m) Aluminum Stem - Gloss White	ST 72 3 GWT
3/4" (19mm) Alum. Stem Coupler - Gloss White	COP 3 GWT

- Standard finish is Gloss White Powder; other RLM colors available.

Description	Order Number
3/4" (19mm) Aluminum Gooseneck Bracket - Gloss White	GB A 3 GWT
3/4" (19mm) Aluminum Gooseneck Bracket - Gloss White	GB B 3 GWT
3/4" (19mm) Aluminum Gooseneck Bracket - Gloss White	GB C 3 GWT
3/4" (19mm) Aluminum Gooseneck Bracket - Gloss White	GB D 3 GWT
3/4" (19mm) Aluminum Gooseneck Bracket - Gloss White	GB E 3 GWT
3/4" (19mm) Aluminum Gooseneck Bracket - Gloss White	GB F 3 GWT
3/4" (19mm) Aluminum Gooseneck Bracket - Gloss White	GB G 3 GWT
3/4" (19mm) Aluminum Gooseneck Bracket - Gloss White	GB H 3 GWT
3/4" (19mm) Aluminum Gooseneck Bracket - Gloss White	GB J 3 GWT
3/4" (19mm) Aluminum Gooseneck Bracket - Gloss White	GB K 3 GWT
3/4" (19mm) Aluminum Gooseneck Bracket - Gloss White	GB P 3 GWT
3/4" (19mm) Aluminum Gooseneck Bracket - Gloss White	GB U 3 GWT

Description	Order Number
Contemporary Wall Bracket - Medium - Gloss White	CWBM 1 GWT
Contemporary Wall Bracket - Long - Gloss White	CWBL 1 GWT
Nostalgic Aluminum Wall Scroll Bracket - Gloss White	DWB 1 GWT

BRACKETS

- See Indoor section for detail on bracket sizes and shapes.
- Standard finish is Gloss White Powder; colors available.
- Designed for mounting to recessed 4" (102mm) octagon box (by others).



Project Name _____ Fixture Type _____
Catalog # _____

G

01/21/14
© 2014
LSI INDUSTRIES INC.

LED 6 INCH WET-LISTED DOWNLIGHT (PDL6K)



COMPLETE KIT - PDL6K comes complete with high-efficiency LED modules, recessed housing and built-in trim.

LEDs - Select high-brightness LEDs. Color temperature 4000K (NW, nominal). CRI = 90 (nominal)

LED MODULE ASSEMBLY - Durable plastic housing integrates LED module, white trim and white baffle reflector. Frosted lens eliminates direct view of LEDs. Torsion springs safely secure LED module in housing. Other trims available, consult factory.

ROUGH-IN HOUSING - Non-IC housing must be kept at least 3" away from insulation. 16-gauge galvanized steel housing includes frame with bar hangers with nails for wood joist. Adjustable 14" to 25" for precise placement. Bar hangers include T-bar notch for T-grid ceilings

DIMMING - PDL6K is dimmable to 10% with standard 120V electronic dimmers. Contact factory for use with incandescent or magnetic low-voltage dimmers.

DELIVERED LUMENS - 900 (HO Output) or 700 (SS)

INPUT POWER - 13 watts (HO); 10 watts (SS)

EXPECTED LIFE - Minimum 50,000 hours.

WARRANTY - Limited 5-year warranty.

LISTING - Wet location. ETL listed to U.S. and Canadian safety standards.

PHOTOMETRICS - LM-79 and LM-80 reports, as well as application layout assistance are available on request. Contact LSI Applications Group or lighting.apps@lsi-industries.com.

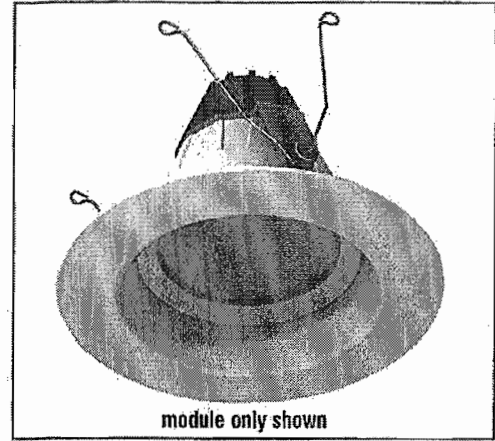

DIMENSIONS

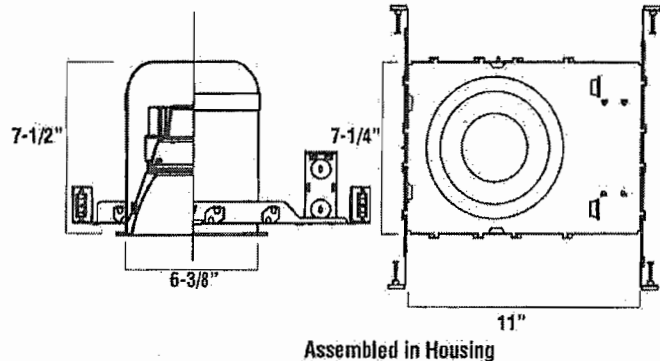
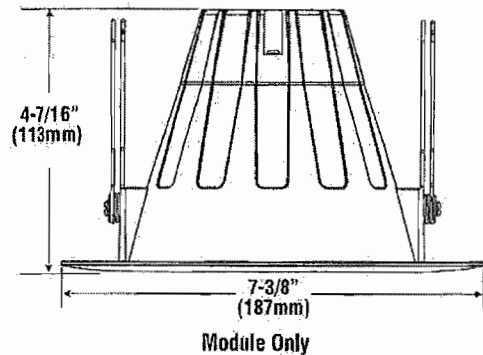

ORDERING INFORMATION

TYPICAL ORDER EXAMPLE: **PDL6K LED HO NW 120**

Prefix	Light Source	Lumen Output	Color Temp	Line Voltage
PDL6K - 6" Downlight (Module & housing)	LED	HO - High Output SS - Super-Seven	NW - Neutral White (4000K)	120 - 120 VAC

PDL6K-LED-HO-NW-120-SD H



Project Name _____ Fixture Type _____
 Catalog # _____

01/21/14
 © 2014
 LSI INDUSTRIES INC.

LED AREA LIGHTS - PATRIOT® SMALL (XPTS3)

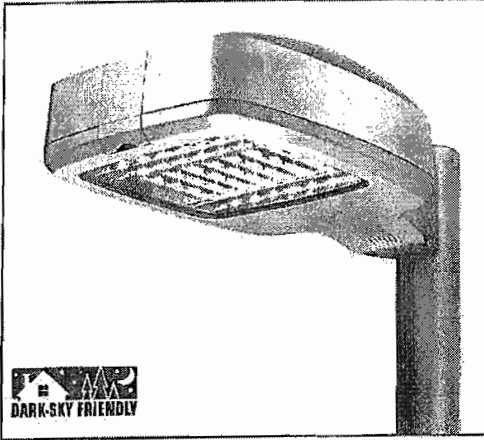

US patent 7828456, 7952293, 8002428, 8177386 and CAN 2736757 and MX patent 29631 and ISRL 49679 and AUS 2008312668 and US & Int'l. patents pending

SMARTTEC™ THERMAL CONTROL - Sensors in the driver enclosure reduce driver current when ambient temperatures exceed 50°C. Current is lowered in imperceptible 5% increments every 5 minutes until safe temperature is reached.

EXPECTED LIFE - Minimum 60,000 hours to 100,000 hours depending upon the ambient temperature of the installation location. See LSI web site for specific guidance.

LEDS - Select high-brightness LEDs in Cool White (5800°K nominal) or Neutral White (4000°K nominal) color temperature. 70 CRI (nominal)

DISTRIBUTION/PERFORMANCE - Types 2, 3, FT and 5. Exceptional uniformity creates bright environment at lower light levels. Improved backlight cutoff minimizes light trespass.

HOUSING - One-piece, die-cast aluminum in a multi-radiused, rectangular shape with mounting arm cast in as an integral part of the housing. All hardware is stainless steel or electro-zinc plated steel.

OPTICAL UNIT - Clear tempered optical grade flat glass lens sealed to die-cast aluminum door assembly. Secures to housing with stainless steel hinge bracket. Integral over-center latch allows easy tool-less access to driver. Optic provided with catch mechanism that limits door swing. One-piece extruded silicone gasket seals optical assembly against the housing.

MOUNTING - Use with 5" traditional drilling pattern. Integral cast mounting arm is flat for square pole applications. Use round pole adaptor (RPPC) to mount to round poles. RPPC must be ordered separately. Extruded 6" arm extension is available (but not required).

ELECTRICAL - Two-stage surge protection (including separate surge protection built into electronic driver) meets IEEE C62.41.2-2002, Location Category C. Available with universal voltage power supply 120-277VAC (UE-50-60Hz input) and 347-480VAC. Optional button-type photocalls (PCI) are available in 120, 208, 240, 277 or 347 volt (supply voltage must be specified). Fixture watts (nominal): LW - 54, SS - 75.

DRIVER - Available in LW (low wattage) and SS (super saver) drive currents. (Driver currents are factory programmed.) State-of-the-art driver technology designed specifically for LSI LED light sources provides unsurpassed system efficiency. Components are fully encased in potting material for IP65 moisture resistance. Driver complies with requirements of FCC title 47CFR Part 15, Class A and B; Part 18, Class A.

OPERATING TEMPERATURE - -40°C to +50°C (-40°F to +122°F)

FINISH - Fixtures are finished with LSI's DuraGrip® polyester powder coat finishing process. The DuraGrip finish withstands extreme weather changes without cracking or peeling, and is guaranteed for five full years. Standard colors include bronze, black, platinum plus, graphite, satin verde green, metallic silver and white. Meets requirements of ASTM B117 1000-hour salt fog and ASTM G155 1000-hour Xenon Arc UV tests (supersedes G53-UVB313).

WARRANTY - LSI LED fixtures carry a limited 5-year warranty.

PHOTOMETRICS - Application layouts are available upon request. Contact LSI Applications Group at lighting.apps@lsi-industries.com

SHIPPING WEIGHT - 30 lbs./13.6Kg

LISTING - ETL listed to U.S. and Canadian safety standards. Suitable for wet locations.

LIGHT OUTPUT - XPTS3						
		# of LEDs	Lumens (Nominal)			
			Type 2	Type 3	Type FT	Type 5
Cool White	LW	63	4300	4100	4500	3300
	SS	63	5400	5100	5600	4200
Neutral White	LW	63	5700	5800	4000	2900
	SS	63	4900	5000	5100	3900

This product, or selected versions of this product, meet the standards listed below. Please consult factory for your specific requirements.



ROHS COMPLIANT

FC CE C



ARRA Funding Compliant

IP65

XPTS3-3-LED-63-LW-CW-UE

K

Also available in traditional light sources



Project Name _____ Fixture Type _____
 Catalog # _____

10/28/13

© 2013

LSI INDUSTRIES INC.

LED AREA LIGHTS - PATRIOT® SMALL (XPTS3)



LUMINAIRE ORDERING INFORMATION

TYPICAL ORDER EXAMPLE: **XPTS3 FT LED 63 SS CW UE WHT PCI120**

Prefix	Distribution	Light Source	# of LEDs	Drive Current	Color Temperature	Input Voltage	Finish	Options
XPTS3 - LED Patriot Small	2 - Type II 3 - Type III 4 - Forward Throw 6 - Type V	LED	63	SS - Super Green LW - Low Watt	CW - Cool White NW - Neutral White	UE - Universal Voltage (120-277) 347-480	BLK - Black BRZ - Bronze GPT - Graphite MSV - Metallic Silver PLP - Platinum Plus SVG - Satin Verde Green WHT - White	PCI120 - 120V Button-Type Photocell PCI208-277 - 208-277V Button-Type Photocell PCI347 - 347V Button-Type Photocell TB - Terminal Block

LUMINAIRE EPA CHART - XPTS3

	Single	1.1
	D180°	2.1
	D90°	1.6
	T90°	2.7
	TN120°	2.8
	Q90°	3.2

Note: House Side Shield adds to fixture EPA. Consult Factory.

ACCESSORY ORDERING INFORMATION (Accessories are field installed)

Description	Order Number	Description	Order Number
RPPC - Round Pole Plate	141940CLR	XPTS3 HSS - House Side Shield Type 2, 3, FT	516850BLK++
FK120 - Single Fusing	FK120*	XPTS3 PLS - Polycarbonate Shield	263016
FK277 - Single Fusing	FK277*	BKS-BO-PTS-WM-* - CLR - Wall Mount Plate	263230CLR
DFK208, 240 - Double Fusing	DFK208,240*	BKA-BO-PTS-EC-6-CLR - Extension Arm	263228CLR
DFK480 - Double Fusing	DFK480*	BKA-BO-BA-8-CLR - Radius Arm	169010CLR
FK347 - Single Fusing	FK347*	BKU-BO-S-19-CLR - Upsweep Bracket for Round and Square Poles	144191CLR

NOTES: *Fusing must be located in the hand hole of pole. **Black only.

DIMENSIONS

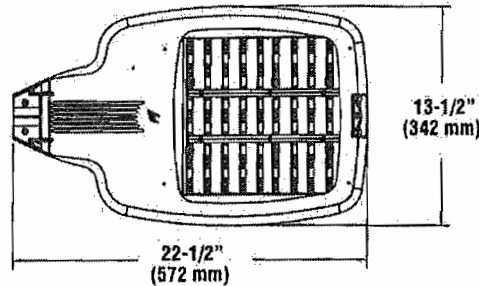
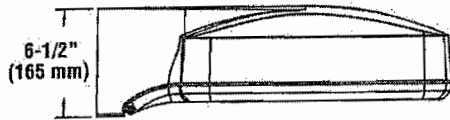

House Side Shield (HSS)
Rear Mounted (516850 BLK)

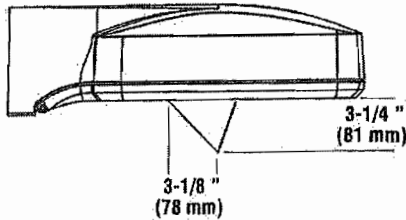

K

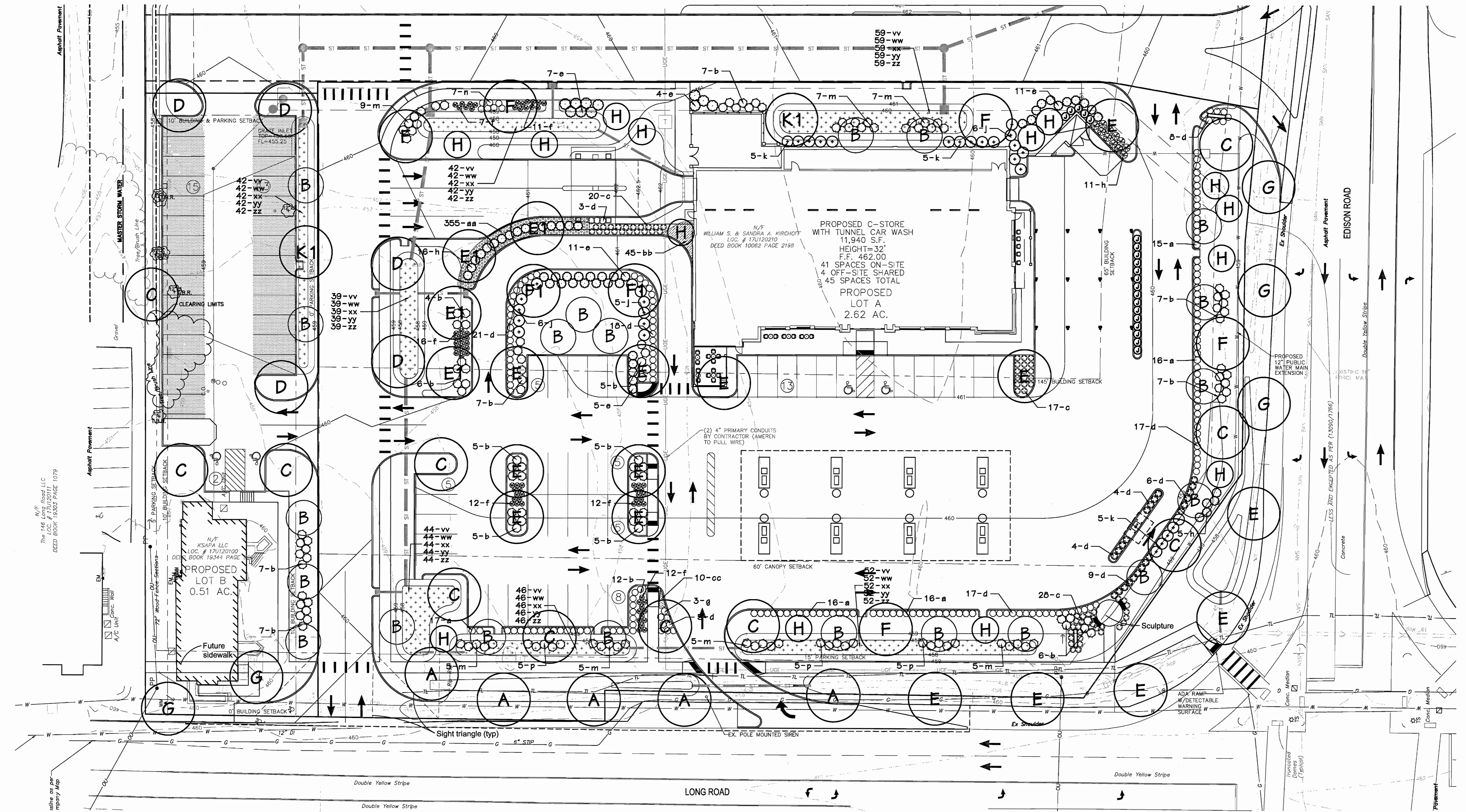

NOTE: Open space percentage for Larson property = 39.0%

NOTE: Open space percentage for Edison Express property = 35.0%

LANDSCAPE PLAN
 SCALE 1" = 20'

BIO-RETENTION PLANTINGS - (3,960 s.f.)

SYMBOL	QUANTITY	BOTANICAL NAME	COMMON NAME	SIZE	REMARKS
vv	324	<i>Carex praegracilis</i>	Tollway Sedge	2' x 2' x 5" DCP	18" O.C.
ww	324	<i>Carex shortiana</i>	Short's Sedge	2' x 2' x 5" DCP	18" O.C.
xx	324	<i>Sporobolus heterolepis</i>	Prairie Dropseed Grass	2' x 2' x 5" DCP	18" O.C.
yy	324	<i>Iris virginica</i>	Southern Blueflag Iris	2' x 2' x 5" DCP	18" O.C.
zz	324	<i>Rudbeckia fulgida</i>	Orange Coneflower	2' x 2' x 5" DCP	18" O.C.

Note: Plug to be planted in clusters of 12-16

PLANTING SCHEDULE

TREES	SYMBOL	QUANTITY	BOTANICAL NAME	COMMON NAME	SIZE	REMARKS	RATE	MATURE HEIGHT
A	5	<i>Gleditsia triacanthos 'inermis'</i>	Thornless Honeylocust	2 1/2"	Canopy	FAST	45'+	
B	21	<i>Cercis canadensis</i>	Redbud	2 1/2"	Ornamental	FAST	25-30'	
C	11	<i>Tilia cordata</i>	Littleleaf Linden	2 1/2"	Canopy	SLOW	45'+	
D	5	<i>Quercus bicolor</i>	Swamp White Oak	2 1/2"	Canopy	MED.	45'+	
E	14	<i>Carpinus caroliniana</i>	American Hornbeam	2 1/2"	Ornamental	MED.	20-35'	
F	5	<i>Acer rubrum 'Frankered'</i>	Red Sunset Maple	2 1/2"	Canopy	FAST	45'+	
G	5	<i>Carpinus betulus</i>	European Hornbeam	2 1/2"	Canopy	MED.	35-40'	
H	14	<i>Picea glauca</i>	White Spruce	6-8'	Evergreen	MED.	30-40'	
J	20	<i>Platycladus orientalis 'Holmstrup'</i>	Holmstrup Oriental Arborvitae	5-6'	Evergreen	SLOW	10-15'	
SHRUBS & LARGE GRASSES								
a	80	<i>Itea virginica 'Sprich'</i>	Little Henry Sweetpire	3 gal.				
b	77	<i>Juniperus x pfitzeriana 'Sea Green'</i>	Sea Green Juniper	5 gal.				
c	64	<i>Rhus aromatica 'Gro-Low'</i>	Gro-Low Sumac	3 gal.				
d	113	<i>Buxus 'Green Velvet'</i>	Green Velvet Boxwood	5 gal.				
e	35	<i>Rosa 'Redrazz'</i>	Knockout Rose	5 gal.				
f	70	<i>Calamagrostis x acutiflora 'Karl Foerster'</i>	Karl Foerster Feather Reed Grass	5 gal.				
g	3	<i>Hydrangea paniculata 'Jane'</i>	Little Lime Hydrangea	5 gal.				
h	32	<i>Miscanthus sinensis 'Yaku Jima'</i>	Yaku Jima Dwarf Maiden Grass	3 gal.				
i	17	<i>Weigela florida 'Alexandra'</i>	Wine and Roses Weigela	5 gal.				
j	15	<i>Ilex 'Mesog/Mesdob'</i>	China Girl/Boy Holly	7 gal.				
k	43	<i>Cornus sericea</i>	Red Twig Dogwood	3 gal.				
m	7	<i>Miscanthus sinensis 'Gracillimus'</i>	Maiden Grass	5 gal.				
n	15	<i>Cornus sericea 'Flaviramea'</i>	Yellow Twig Dogwood	3 gal.				
PERENNIALS								
aa	355	<i>Vinca minor 'Bowles'</i>	Bowles Periwinkle	1 qt.				
bb	60	<i>Liriope muscari 'Big Blue'</i>	Big Blue Liriope	1 gal.				
cc	10	<i>Hemerocallis 'Stella de Oro'</i>	Stella de Oro Daylily	1 gal.				

NOTE: An Inground irrigation system will be provided for all landscape areas.

MITIGATION PLANTING SCHEDULE

SYMBOL	QUANTITY	BOTANICAL NAME	COMMON NAME	SIZE	REMARKS	RATE	MATURE HEIGHT
E1	4	<i>Carpinus caroliniana</i>	American Hornbeam	2 1/2"	Ornamental	SLOW	20-35'
F1	2	<i>Acer rubrum 'Frankered'</i>	Red Sunset Maple	2 1/2"	Canopy	FAST	45'+
K1	2	<i>Taxodium distichum</i>	Bald Cypress	2 1/2"	Canopy	MED.	45'+

City of Chesterfield Tree Preservation and Landscape Requirements:
 1) Street trees shall not be planted closer than three (3) feet to any curb or paved shoulder.
 2) Street trees shall be located within a street right-of-way unless so approved by variance.
 3) Street trees shall not be placed within twenty-five (25) feet of street lights, street signs, and intersections.
 4) No trees shall be planted within ten (10) feet of street inlets or manholes.
 5) No tree, shrub, or planting shall be placed within the sight distance triangle or the area of adjacent right-of-way bounded by the street pavement and the extension of the sight distance triangle.

Revisions:

Date	Description	No.
11/18/13	City Comments	1
12/30/13	City Comments	2
02/13/14	City Comments	3
04/14/14	City Comments	4
05/07/14	City Comments	5
05/28/14	City Comments	6
07/01/14	Plan Revision	7
07/23/14	Plan Revision	8

Drawn: BAR
 Checked: JAS

loomisAssociates
 landscapeArchitects/planners
 707 South 40 Park Drive, Suite 105
 Chesterfield, Missouri 63005-1077
 Phone: 636.865.1077
 Fax: 636.865.1078
 E-mail: info@loomisassociates.com
 Loomis Associates, Inc.
 Missouri State Certificate of Authority #: LAC #00018

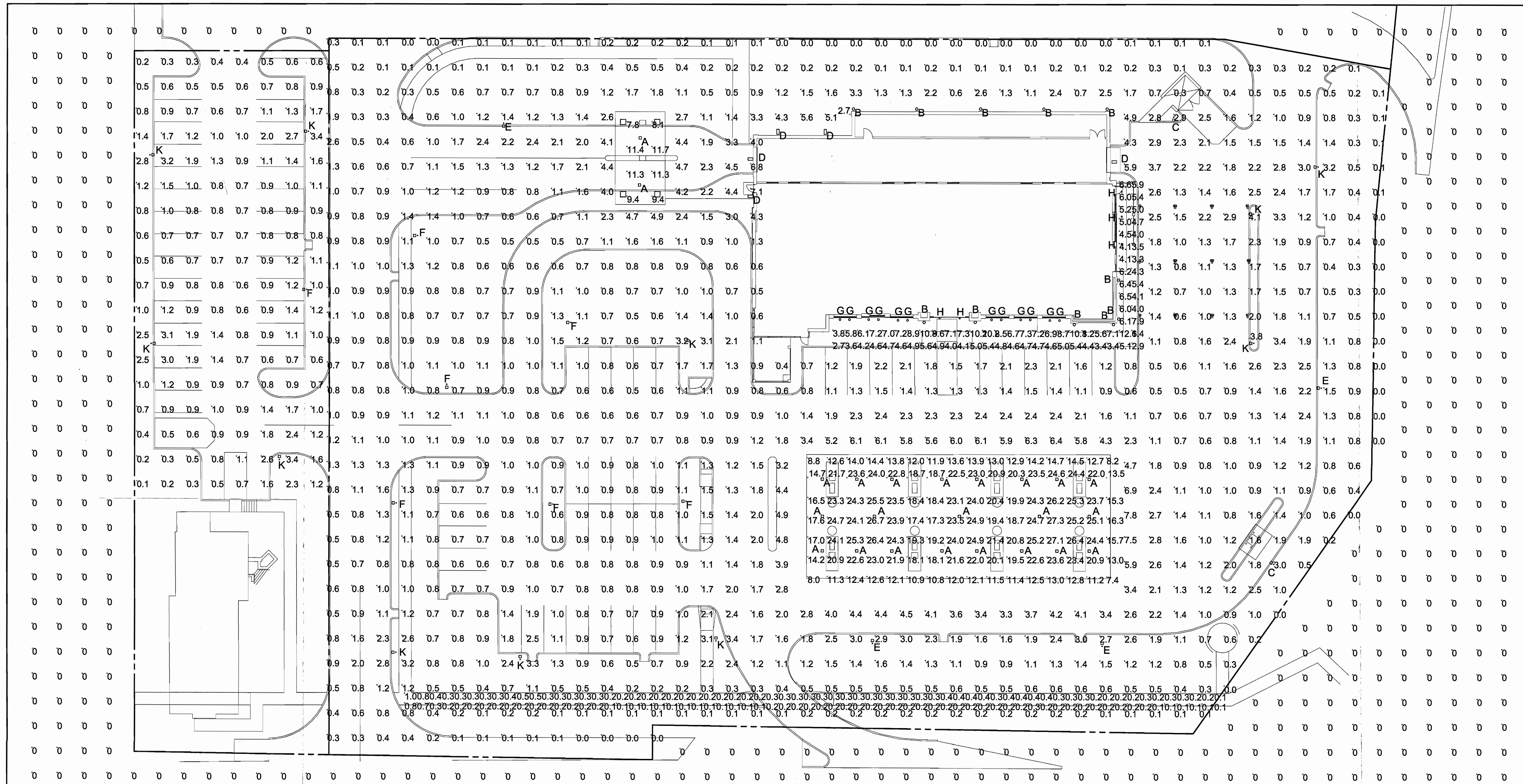

PHOTOMETRIC PLAN
1"=20'

- NOTES**
1. Mounting height of 20' (18'pole, 2'base)
Canopy and wall mounted lights mounted at 15'
 2. Calculations taken at ground level.

STATISTICS

Description	Symbol	Avg	Max	Min	Max/Min	Avg/Min
Adjacent Parking Lot	+	1.1 fc	3.4 fc	0.1 fc	34.0:1	11.0:1
Sidewalk by Road	+	0.2 fc	1.0 fc	0.1 fc	10.0:1	2.0:1
Canopy	+	19.0 fc	27.3 fc	7.4 fc	3.7:1	2.6:1
Car Wash Canopy	+	10.0 fc	11.7 fc	7.8 fc	1.5:1	1.3:1
Main Parking Lot	+	1.3 fc	7.8 fc	0.0 fc	N/A	N/A
Outside Property Line	+	0 fc	0 fc	0 fc	N/A	N/A
Sidewalk by Building	+	5.8 fc	12.1 fc	2.7 fc	4.5:1	2.1:1

LUMINAIRE SCHEDULE

Symbol	Label	Qty	Catalog Number	Description	Lamp	File	Lumens	LLF	Watts
□	A	23	CRU-SC-LED-LW-CW-UE			CRU-SC-LED-LW-CW-UE.ies	Absolute	0.95	76
○	B	11	P6W-LED20-120-F#	P6W DOWNLIGHT CYLINDER 6" DIA. APERTURE	20W LED	P6W-LED20.ies	1650	0.95	21.94
□	C	2	XPTS3-FT-LED-63-LW-CW-UE			XPTS3-FT-LED-63-LW-CW-UE.ies	Absolute	0.95	54
□	D	5	XPWS3-WW-LED-28-350-CW-UE			XPWS3-WW-LED-28-350-CW-UE.ies	Absolute	0.95	34
□	E	4	XPTS3-2-LED-63-LW-CW-UE			XPTS3-2-LED-63-LW-CW-UE.ies	Absolute	0.95	54
□	F	7	XPTS3-5-LED-63-LW-CW-UE			XPTS3-5-LED-63-LW-CW-UE.ies	Absolute	0.95	54
□	K	11	XPTS3-3-LED-63-LW-CW-UE			XPTS3-3-LED-63-LW-CW-UE.ies	Absolute	0.95	54
○	G	12	AD150-10-CW-LED-UE			AD150-10-CW-LED-UE.ies	Absolute	0.95	11.4
○	H	5	PDL6K-LED-HO-NW-120-SD			PDL6K-LED-HO-NW-120-SD.ies	Absolute	0.95	13

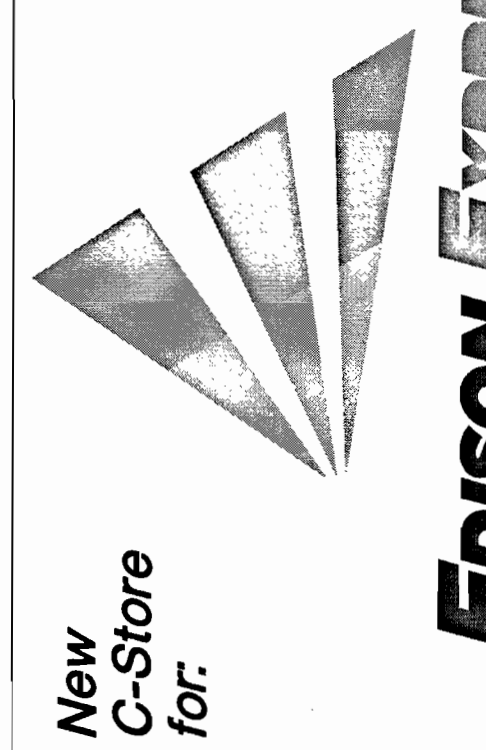
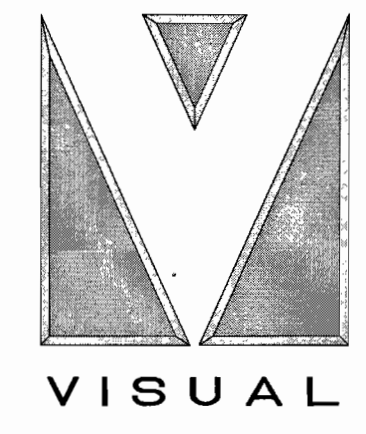

New C-Store for

158 Long Road, Chesterfield, MO 63017

ISSUE DATES:

SITE PLAN REVIEW:	09-30-13
SITE PLAN REVIEW:	10-28-13
SITE PLAN REVIEW:	11-01-13
SITE PLAN REVIEW:	11-14-13
SITE PLAN REVIEW:	12-26-13
ARB REVIEW:	12-30-13
REVISIONS:	02-17-14
REVISIONS:	03-13-14
REVISIONS:	04-07-14
REVISIONS:	06-30-14
REVISED SITE PLAN:	07-21-14

COPYRIGHT © 2014 DAVID W. DIAL ARCHITECTS, P.C.

STATE OF MISSOURI REGISTERED ARCHITECT:
DAVID WILLIAM DIAL - LICENSE NUMBER A-7331
DAVID W. DIAL ARCHITECTS, P.C.
ARCHITECTURAL CORPORATION #2000149091

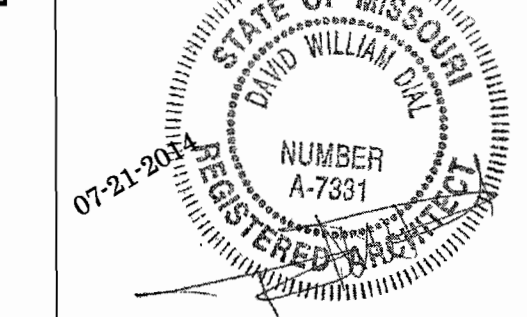

THE ARCHITECT'S SEAL AFFIXED TO THIS SHEET INDICATES THAT THE NAMED ARCHITECT HAS PREPARED OR DIRECTED THE PREPARATION OF THE MATERIAL SHOWN ONLY ON THIS SHEET. OTHER DRAWINGS AND DOCUMENTS, NOT CARRYING THIS SEAL, SHALL NOT BE CONSIDERED PREPARED BY OR THE RESPONSIBILITY OF THE UNDERSIGNED.

dial architects
14364 Manchester Road • Manchester Missouri 63011
636 230 0400
www.dialarchitects.com

SHEET NUMBER:
PHOTOMETRIC PLAN
PROJECT NUMBER: 11180 DATE: 07-21-2014

RECEIVED
City of Chesterfield

MAY 30 2014

Department of Public Services

FIRST AMENDMENT TO SALE AGREEMENT

This FIRST AMENDMENT TO SALE AGREEMENT is made and entered into as of this 1st day of April, 2014, by and between JLA DEVELOPMENT, LLC, as purchaser ("Purchaser"), and KSAPA, L.L.C. ("Seller").
Witnesseth, that

WHEREAS, Purchaser, as purchaser, and Seller, as seller, entered into that certain Sale And Purchase Agreement dated April 15, 2013 (as the same may be amended from time-to-time, the "Sale Agreement") for 0.53± acre tract located in St. Louis County, Missouri. All capitalized terms not herein defined shall have the meanings ascribed to such terms in the Agreement.

NOW, THEREFORE, for and in consideration of the premises and the mutual covenants and agreements contained herein, the Purchaser and Seller hereby agree and provide, as follows:

A. Extension of Larson Contingency Period. The last sentence of Section 5(a) of the Sale Agreement hereby is amended and restated to provide:

"Notwithstanding anything to the contrary contained herein, the Larson Contingency Period under this Agreement shall not extend more than sixteen (16) months plus five (5) days from the Effective Date of this Agreement, excepting upon the prior written consent and agreement of the Seller."

B. Easement for Four (4) Parking Spaces On Larson Adjusted Tract. The approved site plan for the Larson Adjusted Tract is configured with a total of thirty (30) parking spaces to be installed and striped by the Purchaser on the Larson Adjusted Tract in accordance with the Purchaser's post-closing obligations under the Sale Agreement. The approved site plan for the Project Tract being developed by the Purchaser is based upon four (4) parking spaces for the use of the Project Tract being four (4) of the described thirty (30) parking spaces to be installed and striped by the Purchaser on the Larson Adjusted Tract. The four (4) parking spaces are shown as "4 spaces shared with C-Store" on the drawing that is attached hereto as Attachment 1. The parties agree that either (1) the subdivision plat that establishes the platted lots shall include the grant and establishment of a non-exclusive parking easement for said four (4) parking spaces on the Larson Adjusted Tract in favor of the Project Tract; or (2) at Closing, Seller (as the owner of the Larson Adjusted Tract) shall grant the Purchaser (as the owner of the Project Tract) a non-exclusive parking easement for said four (4) parking spaces on the Larson Adjusted Tract. In either case the easement shall be perpetual, except that the easement shall provide that the easement shall be terminable by the owner of the Larson Adjusted Tract if (and only if) the Project Tract no longer needs the four (4) parking spaces in order to comply with and satisfy the zoning and other governmental approvals and requirements applicable to the Project Tract as initially developed and improved as a gas station, convenience store and car wash.

C. Marketing/Advertising/Promotional Agreement. At Closing, Buyer and Seller shall enter into a Marketing/Advertising/Promotional Agreement with respect to the Project Tract and the Larson Adjusted Tract, on terms and conditions mutually acceptable to the parties; and the parties' respective obligations to close are conditioned upon the parties entering into, executing and delivering to each other such Agreement.

D. Miscellaneous. As amended herein and hereby, the Agreement is confirmed and ratified, and is in full force and effect, as of the date hereof. This instrument shall be binding upon and shall inure to the benefit of the parties hereto and their respective successors, heirs and permitted assigns. This instrument shall be governed by and construed in accordance with the laws of the State of Missouri. This instrument may be executed in one or more counterparts, which together shall constitute one and the same instrument. This instrument may be executed via facsimile or by e-mail of a PDF, with the same force and effect as "ink" signatures, and the parties agree that facsimile or PDF execution hereof shall be binding upon the parties.

IN WITNESS WHEREOF, the parties have executed this instrument as of the date first above stated.

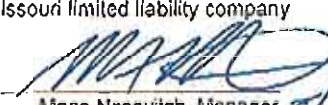
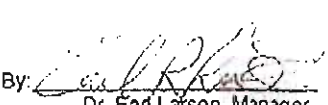
<p>PURCHASER: JLA DEVELOPMENT, LLC, a Missouri limited liability company</p> <p>By:  Mace Nosovitch, Manager 5/30/14</p>	<p>SELLER: KSAPA, L.L.C.</p> <p>By:  Dr. Earl Larson, Manager 5/30/2014</p>
--	--

Attachment 1

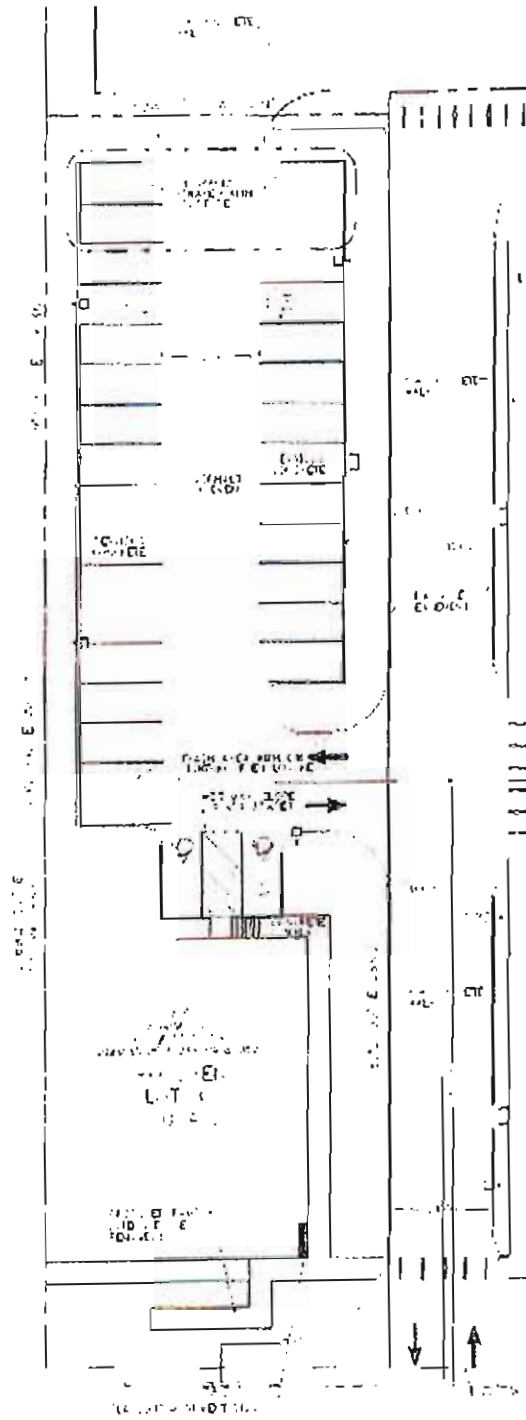

MN 5/30/14
5/2/14
5/30/14

First Amendment to
Sale Agreement for Larson Sale Tract

Attachment 1

RECEIVED 590679 2/RGSZ
City of Chesterfield
MAY 30 2014
Department of Public Services