

**Memorandum**  
**Department of Planning & Public Works**



**To:** Planning and Public Works Committee  
**From:** Annissa McCaskill-Clay, Lead Senior Planner  
**Date:** 06/15/2009  
**RE:** **P.Z. 05-2009 River Crossing (Lot C, Holiday Inn & Suites):** A request for an amendment to City of Chesterfield Ordinance Number 2469 for an increase in building height and maximum development square footage and a decrease in the openspace requirement for River Crossing Development, zoned "PC" Planned Commercial Development, located on the north side of Chesterfield Airport Road, at its intersection with Arnage Boulevard, containing 15.841 acres of land. (17U520061, 17U520072, 17U240066, 17U240077, 17U240088, 17U520171, 17U520182, 17U520193).

**Summary**

On behalf of the owners of River Crossings, Pfaff Partnership is requesting an amendment to City of Chesterfield Ordinance Number 2469. The petitioners/owners of Lot C wish to construct a hotel within the "PC" Planned District-zoned development. Their desired use is permitted under the conditions of Ordinance Number 2469, however the Petitioners are requesting an amendment to the openspace, building height and maximum square footage requirements as set forth in City of Chesterfield Ordinance Number 2469.

At the Public Hearing on May 22, 2009, the Planning Commission provided staff with one (1) issue to review. The Planning Commission requested that staff provide on information on the location of comparable buildings in the area with similar heights as the height being requested in the ordinance amendment. The information provided to the Commission is in the following table:

<b>Development</b>	<b>Building</b>	<b>Built Height</b>
River Crossings	Future Hotel	4 stories or 48 feet, whichever is less
Chesterfield Commons Four	Wehrenberg Theater (Galaxy)	70 feet
Chesterfield Commons Six	Amini's	53 feet
McBride and Son Corporate Center	Hampton Inn	48 feet
Chesterfield Grove	Hilton Garden	4 stories (Ordinance permits a maximum of 50 feet)

The Planning Commission, by a vote of 7-2, recommended of P.Z. 05-2009 with the following changes to Section I.B.2 of the Attachment A:

The maximum height for buildings, exclusive of roof screening **and parapets**, shall not exceed three (3) stories or forty-five (45) feet, whichever is less **with the exception that Lot C (17U520061) shall not exceed four (4) stories or forty-eight (48) feet, whichever is less.**

For your review, please find a copy of Staff's report, the amended Attachment A , and the Preliminary Plan.

Respectfully submitted,



Annissa McCaskill-Clay, AICP  
Lead Senior Planner

CC: Michael G. Herring, City Administrator  
Rob Heggie, City Attorney  
Michael O. Geisel, Director of Planning & Public Works  
Aimee Nassif, Director of Planning & Development Services

## ATTACHMENT A

**All provisions of the City of Chesterfield City Code shall apply to this development except as specifically modified herein.**

### **I. SPECIFIC CRITERIA**

#### **A. PERMITTED USES**

1. The uses allowed in this "PC" Planned Commercial District shall be:
  - a. Barber shops and beauty parlors.
  - b. Bookstores.
  - c. Dry cleaning drop-off and pick-up stations.
  - d. Financial institutions.
  - e. Hotels and motels.
  - f. Medical and dental offices.
  - g. Offices or office buildings.
  - h. Recreational facilities, indoor and illuminated outdoor facilities, including swimming pools, golf courses, golf practice driving ranges, tennis courts, and gymnasiums, and indoor theaters, including drive-in theaters (excluding golf courses, golf practice driving ranges, and drive-in theaters).
  - i. Research facilities, professional and scientific laboratories, including photographic processing laboratories used in conjunction therewith.
  - j. Restaurants, fast food (frontage on Interstate 64/40 shall not be allowed).
  - k. Restaurants, sit down.
  - l. Sales, rental, and leasing of new and used vehicles, including automobiles, trucks, trailers, construction equipment, agricultural equipment, and boats, as well as associated repairs. All vehicles used by business, industry, and agriculture.
  - m. Schools for business, professional, or technical training, but not including outdoor areas for driving or heavy equipment training.
  - n. Service facilities, studios, or work areas for antique salespersons, artists, candy makers, craft persons, dressmakers, tailors, music teachers, dance teachers, typists, and stenographers, including cabinet makers, film

processors, fishing tackle and bait shops, and souvenir sales. Goods and services associated with these uses may be sold or provided directly to the public on the premises.

- o. Stores, shops, markets, service facilities, and automatic vending facilities in which goods or services of any kind, including indoor sale of motor vehicles are being offered for sale or hire to the general public on the premises.

2. Ancillary Uses:

- a. Cafeterias for employees and guest only.
- b. Child care centers, nursery schools, and day nurseries.
- c. Parking areas, including garages, for automobiles, but not including any sales of automobiles, or the storage of wrecked or otherwise damaged and immobilized automotive vehicles for a period in excess of seventy-two (72) hours.
- d. Vehicle repair facilities for automobiles.
- e. Vehicle service centers for automobiles.
- f. Vehicle washing facilities for automobiles.

3. Hours of Operation

Hours of operation for this "PC" Planned Commercial District shall not be restricted.

**B. FLOOR AREA, HEIGHT, BUILDING AND PARKING STRUCTURE REQUIREMENTS**

1. FLOOR AREA

Total building floor area shall not exceed 189,000 square feet.

2. HEIGHT

The maximum height for buildings, exclusive of roof screening and parapets, shall not exceed three (3) stories or forty-five (45) feet, whichever is less with the exception that Tract C (17U520061) shall not exceed four (4) stories or forty-eight (48) feet, whichever is less.

3. BUILDING REQUIREMENTS

- a. A minimum of twenty eight percent (28%) openspace, excluding stormwater areas. This percentage shall be an average of the entire development.
- b. A maximum of eight (8) buildings shall be permitted on this development.

## **C. SETBACKS**

### **STRUCTURE SETBACKS**

No building or structure, other than: a freestanding project identification sign, boundary and retaining walls, light standards, flag poles or fences will be located within the following setbacks:

- a. Lot 1:
  - (1.) One hundred (100) feet from Chesterfield Airport Road right-of-way.
  - (2.) One hundred fifty (150) feet from the western boundary of this district.
  - (3.) Seventy (70) feet from the main entrance into the development.
  - (4.) Sixty (60) feet from the proposed interior road to the north, as proposed on the Preliminary Plan
- b. Lot 2:
  - (1.) One hundred (100) feet from Chesterfield Airport Road right-of-way.
  - (2.) One hundred (100) feet from the building on Lot 1.
  - (3.) Fifty (50) feet from the building on Lot 3.
  - (4.) Sixty (60) feet from the proposed interior road to the north, as proposed on the Preliminary plan.
- c. Lot 3:
  - (1.) One hundred (100) feet from Chesterfield Airport Road right-of-way.
  - (2.) Sixty (60) feet from the eastern boundary of this district.
  - (3.) Sixty (60) feet from the proposed interior road to the north, as proposed on the preliminary plan.

- a. Lot 4/Tract C:
  - (1.) One hundred twenty (120) feet from the western boundary of this district.
  - (2.) Sixty (60) feet from the southern interior road, as proposed on the Preliminary Plan.
  - (3.) Sixty (60) feet from the proposed interior road to the north, as proposed on the preliminary plan.
  
- b. Lot 5/Tract D:
  - (1.) Eighty (80) feet from the eastern boundary of this district.
  - (2.) Sixty (60) feet from the southern interior road, as proposed on the Preliminary Plan.
  - (3.) Sixty (60) feet from the northern interior road to the north, as proposed on the preliminary plan.
  - (4.) One hundred (100) feet from the building on Lot 4.
  
- c. Lot 6:
  - (1.) Sixty (60) feet from Interstate 64/40 right-of-way.
  - (2.) Thirty (30) feet from the western boundary of this district.
  - (3.) Forty (40) feet from the proposed interior road to the south, as proposed on the Preliminary Plan.
  
- d. Lot 7:
  - (1.) Sixty (60) feet from Interstate 64/40 right-of-way.
  - (2.) Thirty (30) feet from the interior road to the south as proposed on the Preliminary Plan.
  - (3.) Sixty (60) feet from the building on Lot 6.

- h. Lot 8/TractD:
  - (1.) Sixty (60) feet from Interstate 64/40 right-of-way.
  - (2.) Seventy (70) feet from the eastern boundary of this district.
  - (3.) Thirty (30) feet from the interior road to the south.

2. **PARKING SETBACKS**

No parking stall, loading space, internal driveway or roadway, except points of ingress or egress, will be located within the following setbacks:

- 1. Fifty (50) feet from the Chesterfield Airport Road right-of-way.
- 2. Fifty (50) feet from Interstate 64/40 right-of-way.
- 3. Twenty (20) feet from the western and eastern boundaries of this district.
- 4. Fifteen (15) feet from internal drives within the site.

**D. PARKING AND LOADING REQUIREMENTS**

- 1. Parking and loading spaces for this development will be as required in the City of Chesterfield Code.
- 2. Parking space dimensions may be reduced to a seventeen (17) foot length as approved by the Planning Commission and City Council and with the following considerations (as prescribed by the Architectural Review Board on May 17, 2001):
  - a. Adequate room is available for the reduction.
  - b. The reduction does not count in the greenspace calculations.
  - c. The design of the space shall be constructed so that landscaping is not harmed by car overhangs.

3. Construction Parking
  - a. The streets surrounding this development and any street used for construction access thereto shall be cleaned throughout the day. The developer shall keep the road clear of mud and debris at all times.
  - b. Provide adequate off-street stabilized parking area(s) for construction employees and a washdown station for construction vehicles entering and leaving the site in order to eliminate the condition whereby mud from construction and employee vehicles is tracked onto the pavement causing hazardous roadway and driving conditions.
  - c. No construction related parking shall be permitted within the Chesterfield Airport Road right-of-way.
4. Parking lots shall not be used as streets.

#### **E. LANDSCAPE AND TREE REQUIREMENTS**

1. The developer shall adhere to the Tree Preservation and Landscape Requirements of the City of Chesterfield Code.

#### **F. SIGN REQUIREMENTS**

1. Signage shall conform to the design guidelines provided by the Petitioner and attached hereto as Exhibit 2.
2. No advertising signs, temporary signs, portable signs, off site signs, or attention getting devices shall be permitted in this development.
3. Ornamental Entrance Monument construction, if proposed, shall be reviewed by the City of Chesterfield, and/or the St. Louis County Department of Highways and Traffic, for sight distance considerations prior to installation or construction.

#### **G. LIGHT REQUIREMENTS**

1. Provide a lighting plan and cut sheet in accordance with the City of Chesterfield Code.
2. Provide for the installation, maintenance, operation and all expenses related thereto for the street lighting along all public streets associated with this development, including Chesterfield Airport Road in perpetuity, as directed by the City of Chesterfield's



Department of Planning and Public Works. The street lighting plan shall comply with Chesterfield Valley Master Street Lighting Plan.

## **H. ARCHITECTURAL**

1. The developer shall submit architectural elevations, including but not limited to, colored renderings and building materials. Architectural information is to be reviewed by the Architectural Review Board and the Planning Commission.
2. Building facades should be articulated by using color, arrangement or change in materials to emphasize the facade elements. The planes of the exterior walls may be varied in height, depth or direction. Extremely long facades shall be designed with sufficient building articulation and landscaping to avoid a monotonous or overpowering appearance.
3. Trash enclosures: The location, material, and elevation of any trash enclosures will be as approved by the Planning Commission on the Site Development Plan. All exterior trash areas will be enclosed with a six (6) foot high sight-proof enclosure complimented by adequate landscaping approved by the Planning Commission on the Site Development Plan. An opportunity for recycling will be provided.
4. Mechanical equipment will be adequately screened by roofing or other material as approved by the Planning Commission.
5. The architectural elevations shall reasonably conform to the elevations submitted with the Preliminary Plan and take into consideration recommendations provided by the Architectural Review Board (May 17, 2001).
6. A material and color palette for the development shall be submitted with the Site Development Concept Plan.
7. Architectural elevations shall conform to design guidelines attached hereto as Exhibit 1.

## **I. ACCESS/ACCESS MANAGEMENT**

1. Access to Chesterfield Airport Road shall be limited to one entrance. The entrance shall generally align with Public Works Drive, which lies on the south side of Chesterfield Airport Road.
2. Lots along Chesterfield Airport Road shall be accessed via a secondary drive off the main entrance. The secondary drive shall be designed to current city standards, extend to the east property line of the development and be located approximately 300 feet from

the Chesterfield Airport Road right-of-way, as directed by the City of Chesterfield and the St. Louis County Department of Highways and Traffic.

No access to the main entrance shall be permitted between Chesterfield Airport Road and the secondary drive, and entrances along each side of the secondary drive shall generally align.

3. Cross access shall be provided to the properties to the east and west of the development. Cross access shall also be provided between lots within the development.
4. The centerline of the interior connector road that parallels Chesterfield Airport Road shall be approximately 300 feet from the Chesterfield Airport Road right-of-way or as directed by the City of Chesterfield and the St. Louis County Department of Highways and Traffic.
5. No entrances shall be allowed from proposed Lot 4 onto the entrance roadway from Chesterfield Airport Road.
6. All entrances onto the roadway that parallels Chesterfield Airport Road from the proposed lots shall align with each other.

**J. PUBLIC/PRIVATE ROAD IMPROVEMENTS, INCLUDING PEDESTRIAN CIRCULATION**

1. Provide additional right-of-way and construct improvements to Chesterfield Airport Road as required by the Department of Planning and Public Works and the St. Louis County Department of Highways and Traffic.
2. Roadway and related improvements shall be constructed prior to 60% occupancy of the retail portion of the site.
3. Sidewalks shall be as proposed on the Preliminary Plan including sidewalks around the perimeter of the office and retail/restaurant structures and internal walkways connecting lots within the development.
4. The interior roadway that parallels Chesterfield Airport Road shall be designed to current City standards.
5. The developer shall provide any additional right-of-way and construct any improvements to Chesterfield Airport Road, as well as to the entrance to the proposed development from Chesterfield Airport Road, as required by the St. Louis County Department of

Highways and Traffic and the City of Chesterfield's Department of Planning and Public Works.

**K. TRAFFIC STUDY**

Prior to Site Development Plan approval, provide a traffic study, including internal and external circulation, for review, and approval, by the City of Chesterfield Department of Planning and Public Works, and the St. Louis County Department of Highways and Traffic.

**N. POWER OF REVIEW**

The Mayor or a Councilmember of the Ward in which a development is proposed may request that the site plan be reviewed and approved by the entire City Council. This request must be made no later than 24 hours before posting the agenda for the next City Council meeting after Planning Commission review and approval of the site plan. The City Council will then take appropriate action relative to the proposal.

**O. STORMWATER**

1. The site shall provide for the positive drainage of storm water and it shall be discharged at an adequate natural discharge point or connected to an adequate piped system.
2. Per the Chesterfield Valley Master Storm Water Plan, a 10 foot wide flat bottom ditch has been constructed along the north property line of this site, and a 15 foot ditch along the south. Chesterfield Valley Storm Water Easements have also been dedicated. Depict the channel and easements on all Site Development Plans and improvement plans. Maintenance of the required channel shall be the responsibility of the property owner.
3. All Chesterfield Valley Master Storm Water Plan improvements shall be operational prior to the paving of any driveways or parking areas.

**Q. GEOTECHNICAL REPORT.**

Provide a geotechnical report, prepared by a registered professional engineer licensed to practice in the State of Missouri, as directed by the Department of Planning and Public Works. The report shall verify the suitability of grading and proposed improvements with soil and geologic conditions and address the existence of any potential sinkhole, ponds, dams, septic fields, etc., and recommendations for treatment. A statement of compliance, signed and sealed by the geotechnical engineer preparing the report, shall be included on all Site Development Plans and Improvement Plans.

## **R. MISCELLANEOUS**

1. All utilities will be installed underground. The development of this parcel will coordinate the installation of all utilities in conjunction with the construction of any roadway on site.
2. All loading docks are to be screened by sound attenuating material.
3. No retail, storage or displays are permitted outside the main building unless one side is attached to said building. Screening for the remaining three (3) sides shall be approved by the Planning Commission as part of the Site Development Plan.
4. Screening for outdoor storage shall be approved by the Planning Commission on the Site Development Plan and shall have the same sight proof materials as the approved color palette for the development.
5. An opportunity for recycling will be provided. All provisions of Chapter 25, Article VII, and Section 25-122 thru Section 25-126 of the City of Chesterfield, Missouri Code shall be required where applicable.

## **II. TIME PERIOD FOR SUBMITTAL OF SITE DEVELOPMENT CONCEPT PLANS AND SITE DEVELOPMENT PLANS**

- A. The developer shall submit a concept plan within 18 months of City Council approval of the change of zoning.
- B. In lieu of submitting a Site Development Concept Plan and Site Development Section Plans, the petitioner may submit a Site Development Plan for the entire development within 18 months of the date of approval of the change of zoning by the City.
- C. Failure to comply with these submittal requirements will result in the expiration of the change of zoning and will require a new public hearing.
- D. Said Plan shall be submitted in accordance with the combined requirements for Site Development Section and Concept Plans. The submission of Amended Site Development Plans by sections of this project to the Planning Commission shall be permitted if this option is utilized.
- E. Where due cause is shown by the developer, this time interval for plan submittal may be extended through appeal to and approval by the Planning Commission.

### **III. COMMENCEMENT OF CONSTRUCTION**

- A. Substantial construction shall commence within two (2) years of approval of the site development concept plan or site development plan, unless otherwise authorized by ordinance.
- B. Where due cause is shown by the developer, the Commission may extend the period to commence construction for not more than one additional year.

### **IV. GENERAL CRITERIA**

#### **A. SITE DEVELOPMENT CONCEPT PLAN SUBMITTAL REQUIREMENTS**

The Site Development Concept Plan shall include, but not be limited to, the following:

- 1. Any site development concept plan shall show all information required on a preliminary plat as required in the City of Chesterfield Code.
- 2. A conceptual landscape plan in accordance with the City of Chesterfield Code to indicate proposed landscaping along arterial and collector roadways.
- 3. A lighting plan in accordance with the City of Chesterfield Code to indicate proposed lighting along arterial collector roadways.
- 4. Comments/approvals from the appropriate Fire District, the St. Louis County Department of Highways and Traffic, Monarch Levee District, Spirit of St. Louis Airport and the Missouri Department of Transportation.

#### **B. SITE DEVELOPMENT SECTION PLAN SUBMITTAL REQUIREMENTS**

The Site Development Section Plan shall adhere to the above criteria and to the following:

- 1. Location map, north arrow, and plan scale. The scale shall be no greater than one (1) inch equals one hundred (100) feet.
- 2. Parking calculations. Including calculation for all off street parking spaces, required and proposed, and the number, size and location for handicap designed.
- 3. Provide open space percentage for overall development including separate percentage for each lot on the plan.

July 13, 2009

4. Provide Floor Area Ratio (F.A.R.).
5. A note indicating all utilities will be installed underground.
6. A note indicating signage approval is separate process.
7. Depict the location of all buildings, size, including height and distance from adjacent property lines and proposed use.
8. Specific structure and parking setbacks along all roadways and property lines.
9. Indicate location of all existing and proposed freestanding monument signs
10. Zoning district lines, subdivision name, lot number, dimensions, and area, and zoning of adjacent parcels where different than site.
11. Floodplain boundaries.
12. Depict existing and proposed improvements within 150 feet of the site as directed. Improvements include, but are not limited to, roadways, driveways and walkways adjacent to and across the street from the site, and significant natural features, such as wooded areas and rock formations, that are to remain or be removed.
13. Depict all existing and proposed easements and rights-of-way within 150 feet of the site and all existing or proposed off-site easements and rights-of-way required for proposed improvements.
14. Indicate the location of the proposed storm sewers, detention basins, sanitary sewers and connection(s) to the existing systems.
15. Depict existing and proposed contours at intervals of not more than one (1) foot, and extending 150 feet beyond the limits of the site as directed.
16. Address trees and landscaping in accordance with the City of Chesterfield Code.
17. Comply with all preliminary plat requirements of the City of Chesterfield Subdivision Regulations per the City of Chesterfield Code.
18. Signed and sealed in conformance with the State of Missouri Department of Economic Development, Division of Professional

Registration, Missouri Board for Architects, Professional Engineers and Land Surveyors requirements.

19. Provide comments/approvals from the appropriate Fire District Monarch Levee District, Spirit of St. Louis Airport and the Missouri Department of Transportation.
20. Compliance with Sky Exposure Plane.

## V. CHESTERFIELD VALLEY TRUST FUND

The developer shall contribute a Traffic Generation Assessment (TGA) to the Chesterfield Valley Trust Fund (No. 556). This contribution shall not exceed an amount established by multiplying the required parking spaces by the following rate schedule:

<b>Type of Development</b>	<b>Required Contribution</b>
TGA Category	Contribution
General Office	\$575.04
General Retail	\$1,725.20
Loading Space	\$2,823.08

If types of development proposed differ from those listed, rates shall be provided by the Saint Louis County Department of Highways and Traffic.

If a portion of the improvements required herein are needed to provide for the safety of the traveling public, their completion as a part of this development is mandatory.

Allowable credits for required roadway improvements will be awarded as directed by the Saint Louis County Department of Highways and Traffic and the City of Chesterfield. Sidewalk construction and utility relocation, among other items, are not considered allowable credits.

As this development is located within a trust fund area established by Saint Louis County, any portion of the traffic generation assessment contribution which remains following completion of road improvements required by the development should be retained in the appropriate trust fund.

Traffic generation assessment contributions shall be deposited with Saint Louis County prior to the issuance of building permits. If development phasing is anticipated, the developer shall provide the traffic generation assessment contribution prior to issuance of building permits for each phase of development. Funds shall be payable to Treasurer, Saint Louis County.

### Water Main

The primary water line contribution is based on gross acreage of the development land area. The contribution shall be a sum of \$693.85 per acre for the total area as approved on the Site Development Plan to be used solely to help defray the cost of constructing the primary water line serving the Chesterfield Valley area.

The primary water line contribution shall be deposited with the Saint Louis County Department of Highways and Traffic. The deposit shall be made before St. Louis County approval of the Site Development Plan unless otherwise directed by the Saint Louis County Department of Highways and Traffic. Funds shall be payable to the Treasurer, Saint Louis County.

### Storm Water

The storm water contribution is based on gross acreage of the development land area. These funds are necessary to help defray the cost of engineering and construction improvements for the collection and disposal of storm water from the Chesterfield Valley in accordance with the Master Plan on file with and jointly approved by Saint Louis County and the Metropolitan Saint Louis Sewer District. The amount of the storm water contribution will be computed based on \$2,201.47 per acre for the total area as approved on the Site Development Plan. The storm water contributions to the Trust Fund shall be deposited with the Saint Louis County Department of Highways and Traffic. The deposit shall be made before the issuance of a Special Use Permit (S.U.P.) by Saint Louis County Department of Highways and Traffic or before the issuance of building permits in the case where no Special Use Permit is required. Funds shall be payable to the Treasurer, Saint Louis County.

### Sanitary Sewer

The sanitary sewer contribution is collected as the Caulks Creek impact fee.

The sanitary sewer contribution within Chesterfield Valley area shall be deposited with the Metropolitan St. Louis Sewer District as required by the District.

The amount of these required contributions for the roadway, storm water and primary water line improvements, if not submitted by January 1, 2010, shall be adjusted on that date and on the first day of January in each succeeding year thereafter in accordance with the construction cost index as determined by the Saint Louis County Department of Highways and Traffic.



## **VI. RECORDING**

Within 60 days of approval of any development plan by the City of Chesterfield, the approved Plan will be recorded with the St. Louis County Recorder of Deeds. Failure to do so will result in the expiration of approval of said plan and require re-approval of a plan by the Planning Commission.

## **VII. OCCUPANCY PERMIT**

Prior to the issuance of any occupancy permit, the existing storm water channels located on this site shall be regraded to restore the channel to the line and grade of the original design.

## **VIII. ENFORCEMENT**

- A. The City of Chesterfield, Missouri will enforce the conditions of this ordinance in accordance with the Plan approved by the City of Chesterfield and the terms of this Attachment A.
- B. Failure to comply with any or all the conditions of this ordinance will be adequate cause for revocation of approvals/permits by reviewing Departments and Commissions.
- C. Non-compliance with the specific requirements and conditions set forth in this Ordinance and its attached conditions or other Ordinances of the City of Chesterfield shall constitute an ordinance violation, subject, but not limited to, the penalty provisions as set forth in the City of Chesterfield Code.
- D. Waiver of Notice of Violation per the City of Chesterfield Code.
- E. This document shall be read as a whole and any inconsistency to be integrated to carry out the overall intent of this Attachment A.



**VIII.B.**

---

690 Chesterfield Pkwy W • Chesterfield MO 63017-0760  
Phone: 636-537-4000 • Fax 636-537-4798 • www.chesterfield.mo.us

---

### **Planning Commission Staff Report**

**Subject:** Issues/Rezoning Vote Report

**Meeting Date:** July 13, 2009

**From:** Annissa McCaskill-Clay, AICP  
Lead Senior Planner

**Location:** North side of Chesterfield Airport Road, at its intersection with  
Arnage Boulevard

**Petition:** P.Z. 05-2009 River Crossings (Lot C, Holiday Inn & Suites)

#### **Proposal Summary**

Pfaff Partnership, on behalf of the owners of River Crossings, is requesting an amendment to City of Chesterfield Ordinance Number 2469. The petitioners/owners of Lot C wish to construct a hotel within the "PC" Planned District-zoned development. This use is currently permitted within the River Crossings, however the Petitioners are requesting an amendment to the openspace, building height and maximum square footage requirements as set forth in City of Chesterfield Ordinance Number 2469.

#### **Department Input**

The Attachment A for this request meets all of the development requirements of the City of Chesterfield for a "PC" Planned Commercial District.

#### **Zoning Analysis**

As stated above, the Petitioners are requesting amendment to the openspace, building height and maximum square footage requirements for the "PC" Planned Commercial District-zoned River Crossings development. Specifically, the petitioners are proposing to make the following changes to conditions within the ordinance:

Criteria	Ordinance 2469	Proposed Change
<b>Maximum Height</b>	A maximum height of the building, exclusive of roof screening, shall not exceed three (3) stories or forty five (45) feet, whichever is less.	<b>A maximum building height, exclusive of roof screening and parapets, shall not exceed four (4) stories or forty eight (48) feet, whichever is less.</b>
<b>Minimum Open Space</b>	A minimum of thirty-one percent (31%) openspace, excluding stormwater areas. This percentage shall be an average of the entire development.	A minimum of <b>twenty-eight</b> percent ( <b>28%</b> ) openspace, excluding stormwater areas. This percentage shall be an average of the entire development.
<b>Maximum Square Footage</b>	The maximum square footage of this development shall not exceed a total of 175,000 square feet.	The maximum square footage of this development shall not exceed a total of <b>189,000</b> square feet

A preliminary plan accompanies all rezoning or ordinance requests when the request involves a Planned District. When a vote is taken on such a request, the vote is to approve the change of zoning with an Attachment A written by Staff. The accompanying preliminary plan has been provided for informational purposes only and is not subject to approval with the Petitioner’s request.

Surrounding Land Use and Zoning

- North: The property to the north, across Interstate 64/Highway 40, is MPD Investments zoned, “PI” Planned Industrial District.
- South: To the south of the subject site, across Chesterfield Airport Road, is Chesterfield Commons Four, zoned “PI” Planned Industrial District.
- East: To the east is Chesterfield Commons Six, zoned “C-8” Planned Commercial District.
- West: To the west is Chesterfield Commons Seven, which was recently rezoned to “PC” Planned Commercial District.



Looking east across Lot 4/Tract C. Chesterfield Commons Six is in the distance.



Looking south across Chesterfield Airport Road



Looking north across the subject site. Interstate 64/Highway 40 in the distance.



Looking west from the subject site at Chesterfield Commons Seven.

### **Comprehensive Plan Analysis**

The subject site is located within Ward 4 of the City of Chesterfield. The Comprehensive Plan designates this area as the Mixed Commercial Use. Areas designated with this land use category have retail and office as appropriate land uses. Depending on the location, some areas may combine warehousing and distribution with the office development.

The Comprehensive Plan shows the area to be bordered by Mixed Commercial Use designated properties to the north, west and east. The properties to the south are designated as Mixed Use.

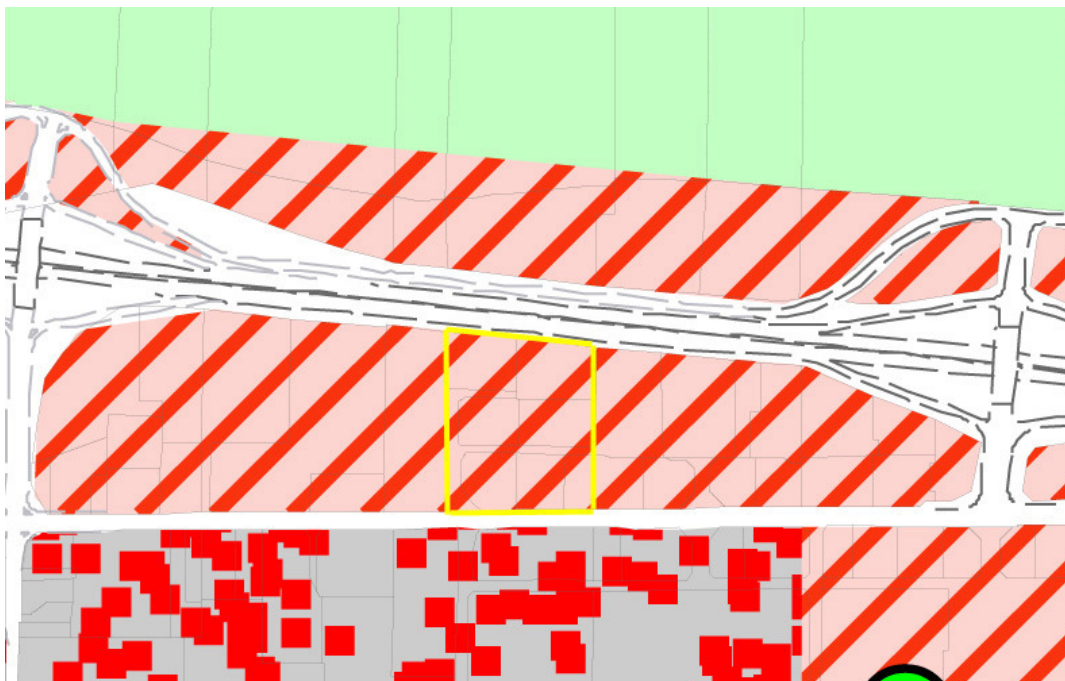

The subject site is not located in any sub-area identified by the Comprehensive Plan, therefore, there are no additional development guidelines for this site.

### **Site Area History**

The River Crossings Development was originally zoned "PC" Planned Commercial District by the City of Chesterfield in August 2001 via Ordinance Number 1772. The ordinance included specific landscape buffer requirements along I-64/Hwy 40. These requirements have been included in all subsequent amendments; Ordinance 1871 in 2002 and Ordinance 2385 in 2007. On September 24, 2007 an Amended Site Development Section Plan, Amended Landscape Plan, Lighting Plan, and Architectural Elevations were approved for Lots 7-8 (Lamborghini of St. Louis). On March 3, 2008 the City Council approved a Minor Subdivision Plat which divided the northern parcels into three lots; Lots 6, 7 and 8. On July 21, 2008 the City of Chesterfield approved Ordinance 2469, which currently governs the site.

## Issues

A Public Hearing before the Planning Commission was held on May 22, 2009. During that meeting, one outstanding issue was provided for staff review. The Planning Commission requested that staff provide information on the location of comparable buildings in the area with similar heights as the height being requested.

Development	Building	Built Height
River Crossings	Future Hotel	4 stories or 48 feet, whichever is less
Chesterfield Commons Four	Wehrenberg Theater (Galaxy)	70 feet
Chesterfield Commons Six	Amini's	53 feet
McBride and Son Corporate Center	Hampton Inn	48 feet
Chesterfield Grove	Hilton Garden	4 stories (Ordinance permits a maximum of 50 feet)

River Crossing is a "PC" Planned Commercial-zoned development. For "PC" Districts, there are height restrictions for office (75 feet) and retail (2 level stories, exclusive of mechanical equipment) uses; however for other uses the maximum height of structures are created in the governing ordinance for the development. The Petitioners are proposing a maximum height of 4 stories or 48 feet, whichever is less.

## Request

Staff has reviewed the request for amendment to City of Chesterfield Ordinance Number 2469 and has no outstanding issues with the request. The Attachment A adheres to all applicable requirements of the City of Chesterfield. Staff requests action by the City of Chesterfield Planning Commission.

### Attachments:

1. Attachment A
2. Preliminary Plan

# PRELIMINARY DEVELOPMENT PLAN FOR HOLIDAY INN RIVER CROSSINGS #11 ARNAGE DRIVE

A TRACT OF LAND BEING TRACT-C OF RIVER CROSSINGS (P.B.350 PG.205),  
IN U.S. SURVEYS 125 AND 126 TOWNSHIP 45 NORTH, RANGE 4 EAST OF THE  
5TH PRINCIPLE MERIDIAN CITY OF CHESTERFIELD, ST. LOUIS COUNTY, MISSOURI

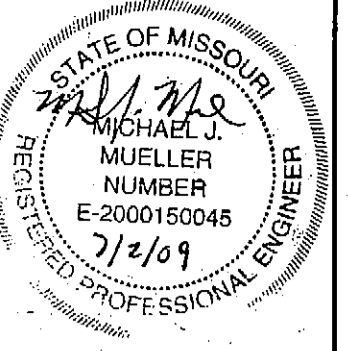

THE SEAL AND SIGNATURE APPLY ONLY TO THE DOCUMENT TO WHICH THEY ARE ATTACHED. THE SIGNER OF THIS DOCUMENT EXPRESSLY DISCLAIMS ANY AND ALL RESPONSIBILITY FOR DOCUMENTS THAT DO NOT BEAR HIS SEAL AND SIGNATURE INCLUDING, BUT NOT LIMITED TO, DRAWINGS, SPECIFICATIONS, ESTIMATES, REPORTS AND OTHER SIMILAR INSTRUMENTS OF SERVICES INTENDED TO BE USED FOR THIS PROJECT.

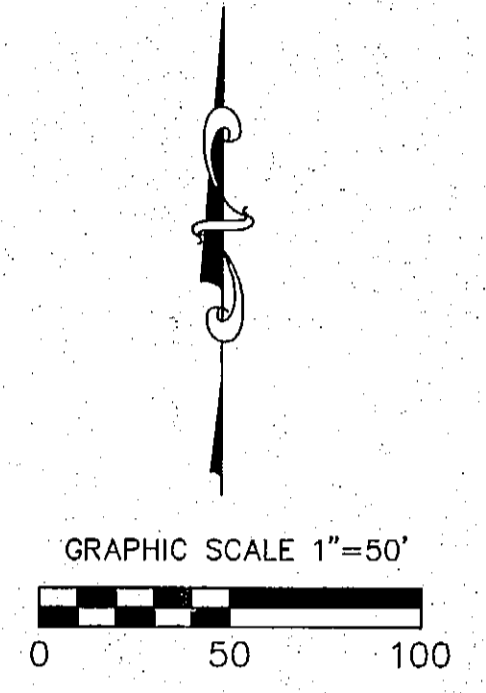
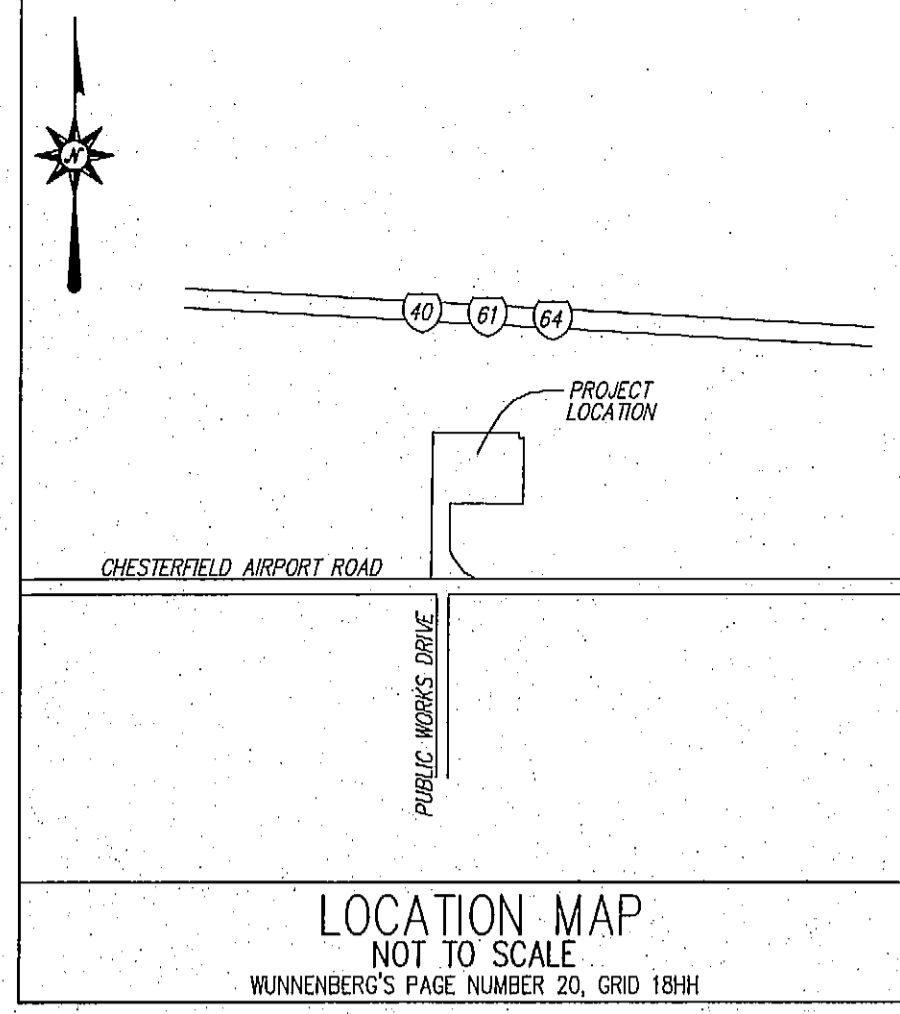

### INDEX OF SHEETS

OVERALL DEVELOPMENT PLAN	C 1.0
TRACT C DEVELOPMENT PLAN	C 2.0

LINE	BEARING	DISTANCE
L1	N00°35'51" E	20.00'
L2	S89°23'45" E	19.60'
L3	S37°17'49" E	66.38'
L4	S80°14'39" E	56.88'

CURVE	ARC	RADIUS	CHORD BEARING	CHORD
C1	61.49'	93.00'	S18°21'23" E	60.38'

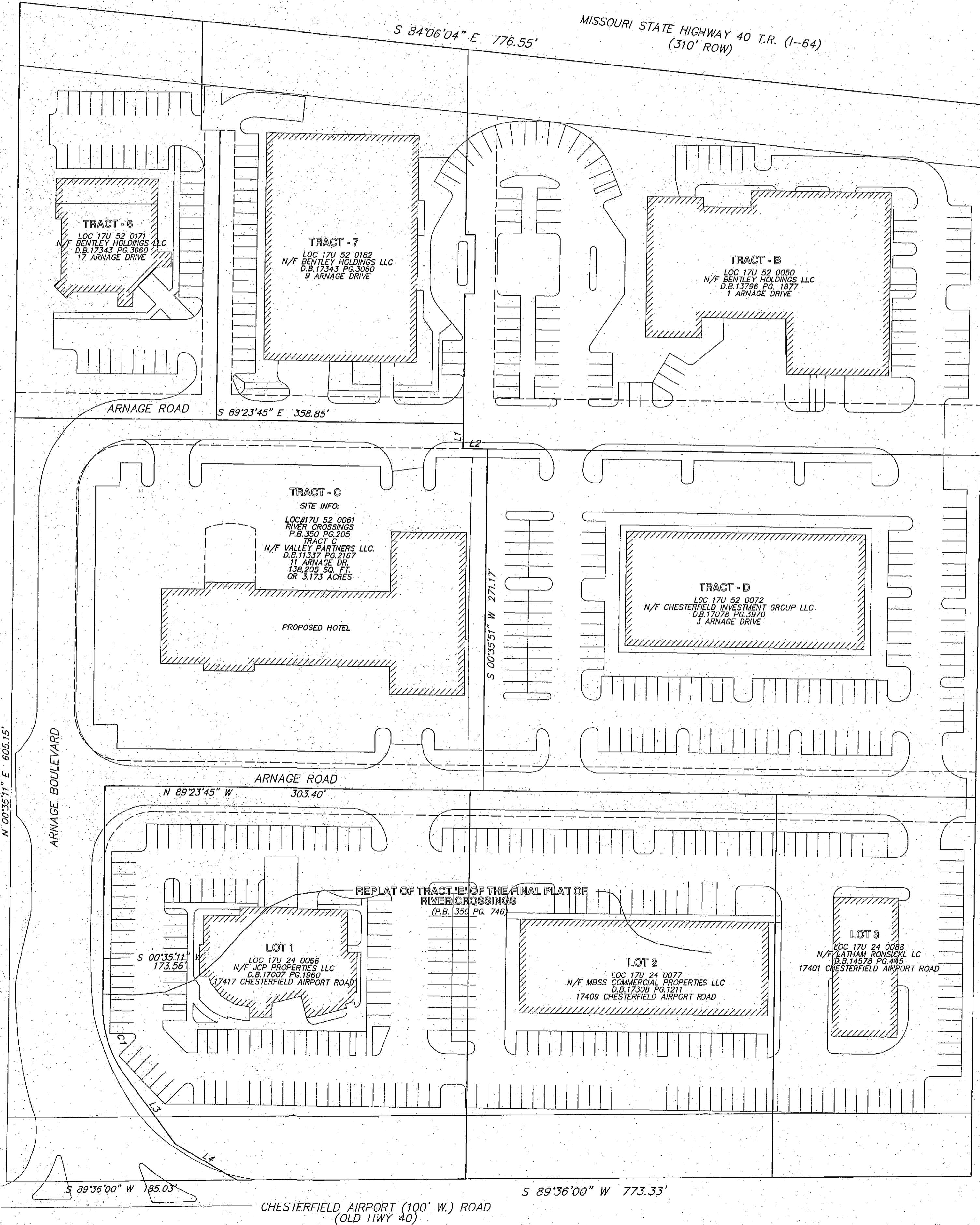

#### AREA CALCULATIONS

<b>LOT 1</b>	
TOTAL AREA.....	1.97 Ac.
OPEN SPACE.....	0.827 Ac.
PERCENT OPEN SPACE.....	32 %
<b>LOT 2</b>	
TOTAL AREA.....	1.73 Ac.
OPEN SPACE.....	0.561 Ac.
PERCENT OPEN SPACE.....	32 %
<b>LOT 3</b>	
TOTAL AREA.....	1.10 Ac.
OPEN SPACE.....	0.356 Ac.
PERCENT OPEN SPACE.....	32 %
<b>TRACT B</b>	
TOTAL AREA.....	2.82 Ac.
OPEN SPACE.....	1.052 Ac.
PERCENT OPEN SPACE.....	37 %
<b>TRACT C</b>	
TOTAL AREA.....	3.17 Ac.
OPEN SPACE.....	0.679 Ac.
PERCENT OPEN SPACE.....	21 %
<b>TRACT D</b>	
TOTAL AREA.....	2.46 Ac.
OPEN SPACE.....	0.649 Ac.
PERCENT OPEN SPACE.....	26 %
<b>TRACT 6</b>	
TOTAL AREA.....	1.17 Ac.
OPEN SPACE.....	0.592 Ac.
PERCENT OPEN SPACE.....	51 %
<b>TRACT 7</b>	
TOTAL AREA.....	1.42 Ac.
OPEN SPACE.....	0.540 Ac.
PERCENT OPEN SPACE.....	38 %
TOTAL AREA.....	15.84 Ac.
TOTAL OPEN SPACE.....	3.056 Ac.
TOTAL %.....	31.9 %
TOTAL OPEN SPACE W/OUT STORMWATER AREAS.....	4.251 Ac.
TOTAL AREA W/OUT STORMWATER AREAS.....	15.034 Ac.
TOTAL OPEN SPACE % W/OUT STORMWATER AREAS.....	28.3 %

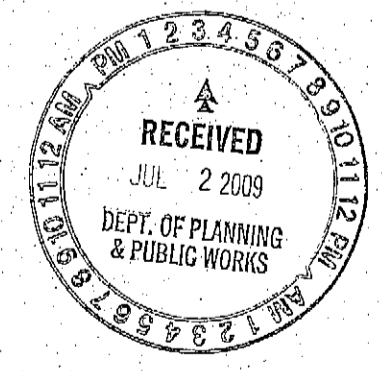

#### ENGINEERS CERTIFICATION

THIS SITE PLAN HAS BEEN PREPARED FOR PRELIMINARY PLANNING PURPOSES IN ACCORDANCE WITH THE GOVERNING AUTHORITY, AND SHALL NOT BE CONSTRUED AS A FINAL ENGINEERING DOCUMENT. SITE IMPROVEMENT PLANS CONTAINING FINAL ENGINEERING DESIGN SHALL BE COMPLETED UPON APPROVAL OF THE SITE PLAN.

Revisions

PREPARED FOR:  
OHM GROUP  
10812 ST CHARLES ROCK ROAD  
ST. ANN, MO 63074  
314-209-9200

HOLIDAY INN  
RIVER CROSSINGS  
#11 ARNAGE DR.  
PRELIMINARY  
DEVELOPMENT PLAN

Project # 09-019  
Date 5/13/09  
Checked By M.J.M.  
Drawn By M.T.G.  
File Name: 09-019 SDP

**CORNERSTONE**  
LAND SURVEYING &  
CIVIL ENGINEERING, INC.  
CORPORATION NUMBER 200606997  
2705 DOUGHERTY FERRY RD., SUITE 100  
ST. LOUIS, MO. 63122 (314)966-9987 (314)966-0329(FAX)

MSD P# BASE MAP ZIP CODE  
Sheet Number  
C 10

# TRACT C DEVELOPMENT PLAN

**LINE TYPE LEGEND**

- EX. SANITARY SEWER
- PROP. SANITARY SEWER
- EX. STORM SEWER
- PROP. STORM SEWER
- EX. WATER LINE
- PROP. WATER LINE
- TELEPHONE LINE
- GAS LINE
- OVERHEAD ELECTRIC
- UNDERGROUND ELECTRIC
- FENCE LINE
- TREE LINE

**SYMBOL LEGEND**

- STORM MANHOLE
- SANITARY MANHOLE
- TELEPHONE MANHOLE
- ELECTRIC MANHOLE
- CURB INLET
- AREA INLET
- DOUBLE CURB INLET
- GRADED INLET
- WATER METER
- WATER VALVE
- GAS METER
- GAS VALVE
- FIRE HYDRANT
- UTILITY POLE
- TREE
- SIGN
- LIGHT
- TRAFFIC CONTROL BOX
- BORING
- FLAGPOLE
- HANDICAP PARKING SPACE
- MAILBOX
- ELECTRIC PEDESTAL
- ELECTRIC METER
- CABLE PEDESTAL
- TELEPHONE PEDESTAL
- GUY WIRE
- CLEANOUT
- PARKING METER
- BOLLARD
- IRRIGATION CONTROL VALVE

**ABBREVIATION LEGEND**

- TF TOP OF FOUNDATION
- FF FINISHED FLOOR
- BF BASEMENT FLOOR
- CONC. CONCRETE
- T TOP ELEVATION
- FL FLOW LINE ELEVATION
- TO BE REMOVED
- TO BE REMOVED & REPLACED
- UP USE IN PLACE
- TEA TO BE ABANDONED
- EX EXISTING
- TYP TYPICAL
- CO CLEAN OUT
- DS DOWN SPOUT
- MIN. MINIMUM
- R RADIUS
- PS PARKING SPACE
- EJ EXPANSION JOINT

**HATCH LEGEND**

- CONCRETE
- ASPHALT
- GRAVEL

LINE	BEARING	DISTANCE
L1	N00°35'51"E	20.00'
L2	S89°23'45"E	19.60'
L3	S37°17'49"E	66.38'
L4	S60°14'59"E	56.86'

CURVE	ARC	RADIUS	CHORD BEARING	CHORD
C1	61.49'	93.00'	S18°21'23"E	60.38'

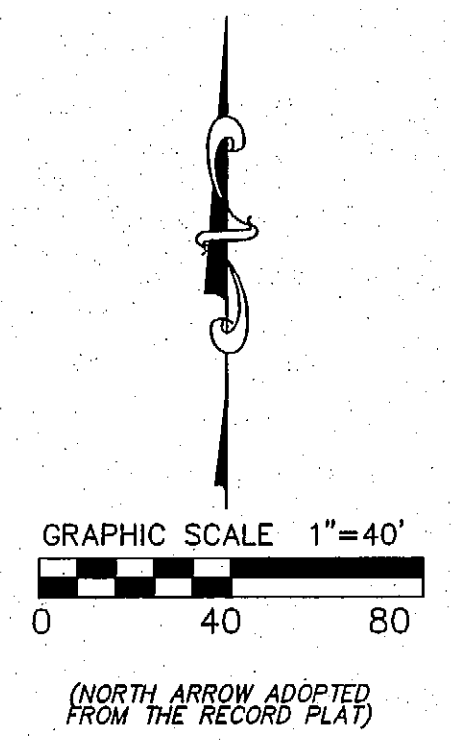
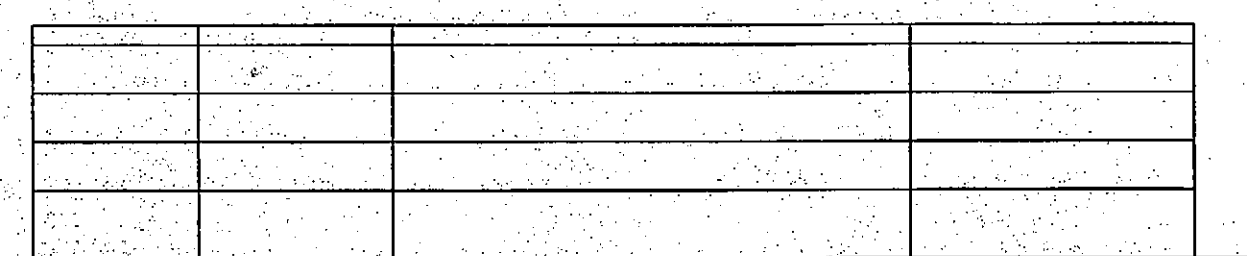
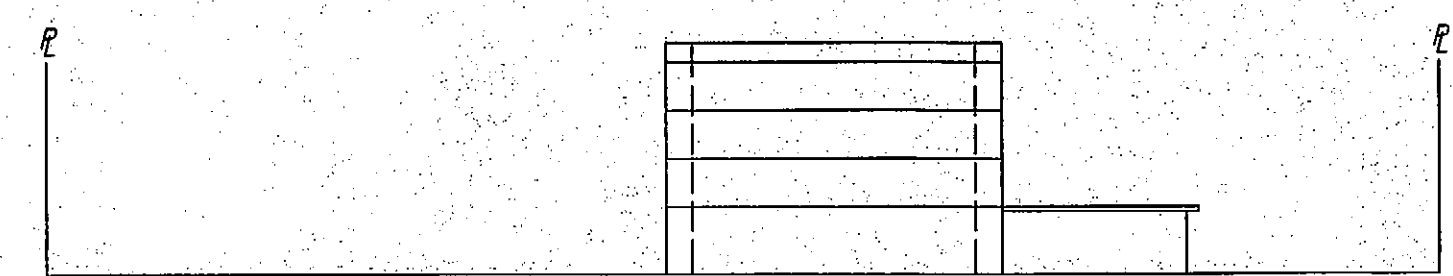
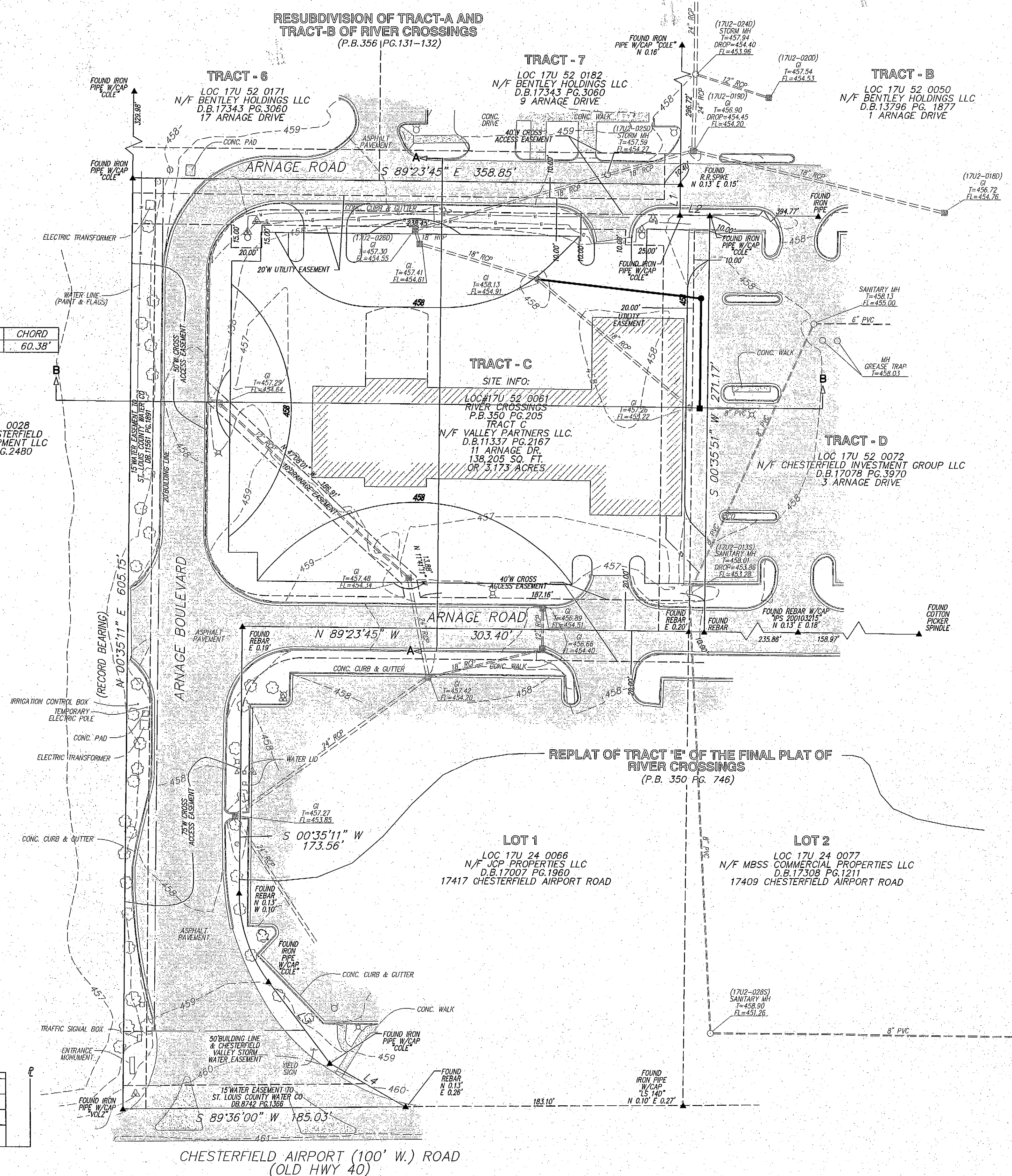

A TRACT OF LAND BEING TRACT-C OF RIVER CROSSINGS (P.B.350 PG.205), IN U.S. SURVEYS 125 AND 126 TOWNSHIP 45 NORTH, RANGE 4 EAST OF THE 5TH PRINCIPLE MERIDIAN CITY OF CHESTERFIELD, ST. LOUIS COUNTY, MISSOURI

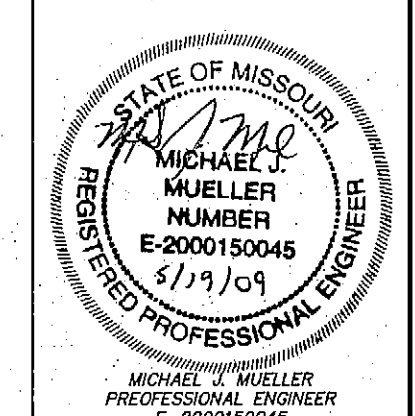

THE SEAL AND SIGNATURE APPLY ONLY TO THE DOCUMENT TO WHICH THEY ARE AFFIXED. THE SIGNER OF THIS DOCUMENT EXPRESSLY DISCLAIMS ANY AND ALL RESPONSIBILITY FOR DOCUMENTS THAT DO NOT BEAR HIS SEAL AND SIGNATURE INCLUDING, BUT NOT LIMITED TO, DIMENSIONS, SPECIFICATIONS, ESTIMATES, REPORTS AND OTHER SIMILAR INSTRUMENTS OF SERVICES INVENTED TO BE USED FOR THIS PROJECT.

Revisions

PREPARED FOR:  
HOLIDAY INN  
RIVER CROSSINGS  
#11 ARNAGE DR.  
OHM GROUP  
10812 ST. CHARLES ROCK ROAD  
ST. ANN, MO 63074  
314-209-9200

PRELIMINARY DEVELOPMENT PLAN

Project # 09-019  
Date 05/13/09  
Checked By M.J.M.  
Drawn By M.T.G.  
File Name: 09-019 SDP

**CORNERSTONE**  
LAND SURVEYING &  
CIVIL ENGINEERING, INC.  
CORPORATION NUMBER 200606597  
2705 DOUGHERTY FERRY RD., SUITE 100  
ST. LOUIS, MO. 63122 (314)966-9987 (314)966-0288(FAX)

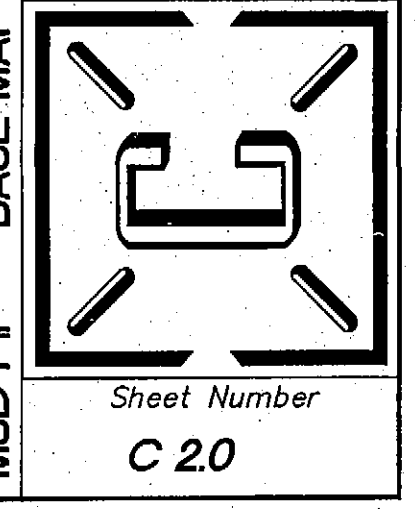

**ENGINEERS CERTIFICATION**  
THIS SITE PLAN HAS BEEN PREPARED FOR PRELIMINARY PLANNING PURPOSES IN ACCORDANCE WITH THE GOVERNING AUTHORITY, AND SHALL NOT BE CONSIDERED AS A FINAL ENGINEERING DOCUMENT. SITE IMPROVEMENT PLANS CONTAINING FINAL ENGINEERING DESIGN SHALL BE COMPLETED UPON APPROVAL OF THE SITE PLAN.