

Planning Commission Staff Report

Project Type:	Architectural Specialty Lighting Package
Meeting Date:	July 8, 2019
From:	Andrew Stanislav, Planner 
Location:	17485 North Outer Forty Road
Description:	<u>MPD Investments, Lot 1 (Metro Lighting) Lighting Package:</u> Architectural Specialty Lighting Package for a 4.02 acre tract of land zoned "PI" Planned Industrial District located on the north side of North Outer 40 Road west of Boone's Crossing (17U520148).

PROPOSAL SUMMARY

The request is for an Architectural Specialty Lighting Package in the MPD Investments subdivision for the Metro Lighting location to illuminate the south elevation facing North Outer 40 Road and the I-64/US-40 corridor. Specifically, this lighting package is seeking approval for the use of color LED up-lighting above the solar panel awning along the west and east sides of the south elevation as well as within the center arch alcove feature above the storefront entry. One static color scheme with a maximum of three (3) colors is proposed per business day and to remain static from initiating illumination at sunset until ceasing illumination at 11:00 pm.

The Architectural Review Board (ARB) reviewed this project at their March 14, 2019 meeting which is detailed later in this report. This item was subsequently scheduled to be considered at the April 8, 2019 Planning Commission meeting, though a motion was passed to postpone this item at the request of the applicant in order to address outstanding concerns.

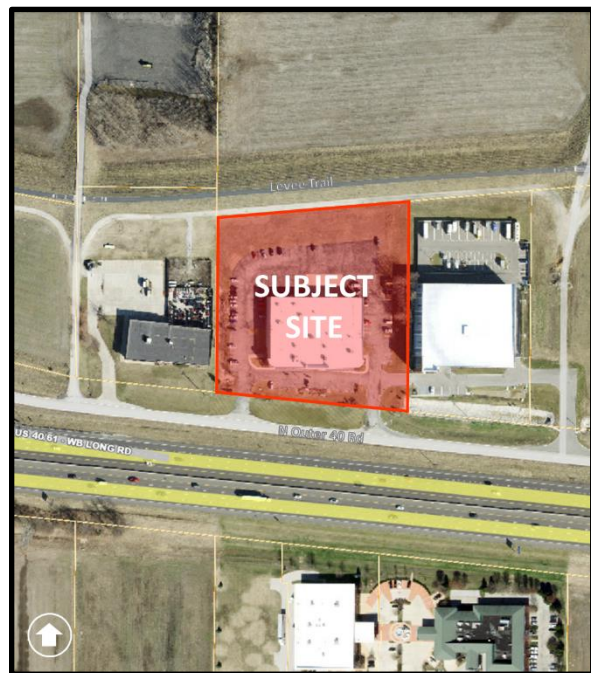

Figure 1: Aerial Image

HISTORY OF SUBJECT SITE

According to St Louis County records, the building was built in 1989. Over the years there have been many amendments to elevations and to the site itself. The site's current governing ordinance is City of Chesterfield Ordinance 2989, which amends City of Chesterfield Ordinance 2411.

In 2017, the applicant submitted an application for Amended Architectural Elevations for color-changing LED up-lighting at this property in a similar manner as currently requested through this Lighting Package. The light fixtures were already in place at the time an application was submitted, and a notice of violation was given and the lighting was turned off in order to go through the necessary approval process. On January 12, 2017, the Architectural Review Board (ARB) recommended approval of the Amended Architectural Elevations by a vote of 6-0 with the following conditions:

1. The colors be limited to two, with a primary color along the band above the solar panels and, if desired, a secondary color under the archway.
2. The colors be static for a 24-hour period, including from sun up to sun down.

Subsequently, the Planning Commission considered the Amended Architectural Elevations on February 13, 2017 and passed a motion to deny approval by a vote of 7-0. At that time, the Planning Commission noted concerns regarding light spillage and setting a precedent for other developments in the City.

Since this original consideration, the City of Chesterfield introduced the Architectural Specialty Lighting Package via Ordinance 3001 which was approved in May 2018. As of February 2019, the light fixtures at Metro Lighting remain mounted on the building and are turned off.

LAND USE AND ZONING OF SURROUNDING PROPERTIES

The land use and zoning for the properties surrounding this parcel are described below:

Direction	Zoning	Land Use
North	"FPNU" Flood Plain Non-Urban District	Vacant/undeveloped across levee
South	"PC" Planned Commercial District	Retail/car dealerships across I-64
East	"PI" Planned Industrial District	Self-storage facility
West	"C-8" Planned Commercial District	Motorsport retailer

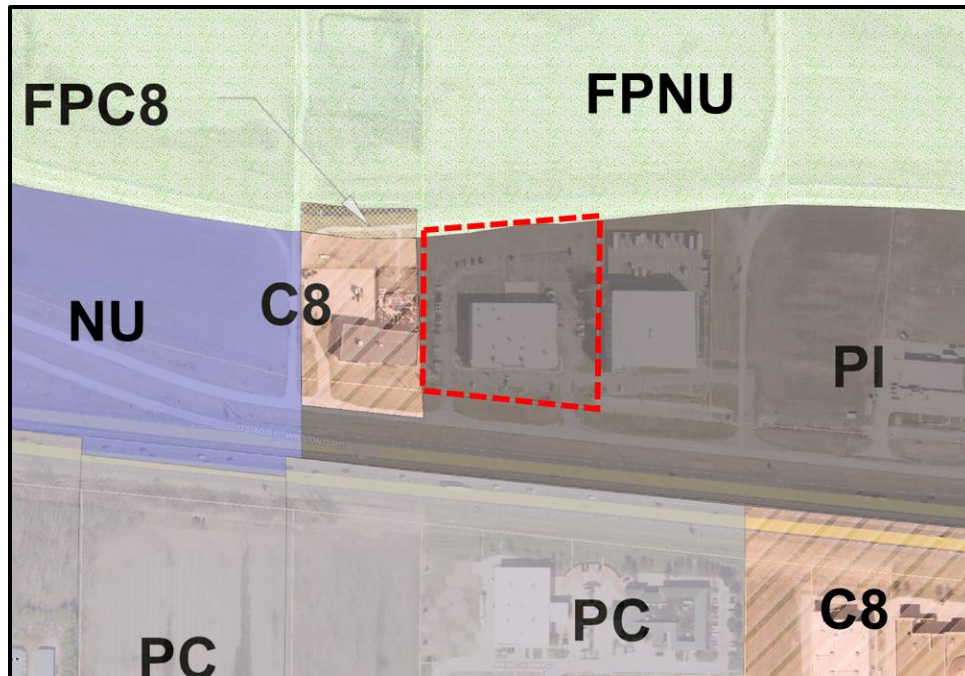

Figure 2: Zoning Map

COMPREHENSIVE PLAN ANALYSIS

The Chesterfield Valley Policies Element of the City’s Comprehensive Plan includes specific design policies to be applied to commercial and industrial development. These policies are intended to address concerns of the image presented by development along the highway corridor, including lighting:

- **2. Lighting of Buildings Along I-64/US-40** – The facades of buildings facing I-64/US-40 should be lighted to provide an attractive image at night for individuals traveling along I-64/US-40.

The Comprehensive Plan serves as the City’s guiding document in implementing the Community’s vision for development and has specifically called attention to reviewing lighting along the I-64/US-40 corridor to ensure that the aesthetics and effect are of high quality.

REQUEST OVERVIEW

The request is for 34 permanently mounted and low-profile LED ColorGraze MX4 fixtures with an extruded aluminum finish to provide color up-lighting along the southern façade of the Metro Lighting building along the I-64/US-40 corridor. The fixtures are mounted along the east and west sides of the south elevation as well as within the central arch alcove feature above the storefront entry.

The proposed programming for the lighting display is to be one static color scheme with a maximum of three (3) colors displayed at one time, specifically with one color on the central arch feature, one color on the west side of the front elevation, and one color on the east side of the front elevation. The color scheme displayed would remain static from illumination at sunset until

ceasing illumination at 11:00 pm. Different static color schemes can be used each time the display is in use; however, **there will be no changes or transitions of color during operation.**

Figure 3 below depicts an example of the lighting display on the building utilizing two (2) colors, and also clarifies the architectural features noted as the central arch feature above the storefront entry as well as the flanking sides on both the west and east sides of the front elevation.



Figure 3: Example light display with two (2) colors

STAFF ANALYSIS

The Unified Development Code (UDC) allows for Architectural Specialty Lighting Packages (Sec. 31-04-03.C) to provide comprehensive, complementary and unified architectural specialty lighting throughout a single development while recognizing that criteria pertaining to site lighting may no longer be applicable in its entirety or portions thereof.

This is the second applicant to utilize the specialty lighting package application. Review factors include color, intensity, impact on surrounding properties, and accentuation of architectural features of a development. As this request is for specialty lighting, specifically for up-lighting along the south façade of the Metro Lighting building, any other light fixtures on the property would be required to comply with the regulations established in the Unified Development Code. The UDC provides several considerations for Architectural Specialty Lighting Packages:

- *Architectural specialty lighting should highlight and accentuate traditional building detailing and architectural features. Additionally, precise lighting applications should highlight distinctive architectural features.*

The applicant has stated in their narrative statement that the proposed fixtures were selected to highlight the center arch feature above the storefront entry as well as the two flanking sides to the west and east along the south elevation. The narrative statement notes that “this is a simple and sophisticated way to highlight the building’s architectural elements in a classic manner without drawing excessive attention and remain unobtrusive.”

- *The color temperature of architectural specialty lighting should underscore the building materials and character. Also, when non-traditional lighting color is requested, changes in color shall be limited to one (1) change within any twenty-four (24) hour time period. Modifications to this standard shall require a 2/3 vote of the Planning Commission. Additionally, architectural specialty lighting should be unobtrusive in intensity and should not turn a building into an attention-getting device or blanket signage.*

The color of the existing building is of neutral gray tones. The UDC states that color temperature should underscore the building materials and colors, however the applicant is requesting the full spectrum of colors for use in creating static color schemes and therefore a large spectrum of color temperatures. The applicant has provided several photos of the building’s south elevation lit in a variety of colors for reference. The two images below in Figure 4 depict some of the programming options within the context of the surrounding area.



Figure 4: Example photos of proposed lighting display

The applicant has indicated that the lighting in the center arch feature as well as the sides east and west of the storefront will each project a static color and not cycle through the color spectrum. A maximum of three (3) static colors are proposed for the lighting display at one time, with one individual color illuminating each of these three architectural features. As such, displays may feature between one and three individual colors on the south elevation of the building at one time.

The light levels for the center, left, and right portions of the south elevation are indicated on the photometric plans provided with the Lighting Package submittal. The maximum footcandle level is 209, which is present in the area closest to the south elevation wall on the left and right sides of the building at the very top edge of the roofline. The maximum footcandle level for the center

arch feature area is 54 and is also located closest to the south elevation wall. Minimum footcandle levels range between 0 and 28 for these three areas. Additionally, a photometric plan was provided for the front drive area nearest to the south elevation of the building with lighting levels in compliance with the UDC.

The applicant notes that they intend to provide a tasteful appearance with the proposed display with the goal of reflecting Metro Lighting’s professional image in the lighting industry.

- *All proposed light fixtures should be permanently mounted.*

The proposed fixtures are permanently mounted above the solar panel canopy to the east and west of the storefront fourteen (14) feet above grade as well as within the center arch alcove feature above the storefront entry ten (10) feet above grade. All fixtures are mounted at a 90-degree angle perpendicular to the façade.



Figure 5: Photos of permanently mounted light fixtures

- *Architectural specialty lighting shall not interfere with or obscure the public's capacity to receive information, or cause visual confusion by interfering with pedestrian or vehicular traffic. Architectural specialty lighting shall conform to the character of the community, enhance the visual harmony of development, and preserve the public health, convenience, welfare and/or safety within the City of Chesterfield by maintaining the high aesthetic quality of the community.*

The applicant has recognized in the narrative statement that off-site glare and distraction to nearby drivers and pedestrians is addressed by installing **two unique types of shielding fixtures**:

Masking Shield. These light shields are mounted on the side of each fixture to direct light upward and avoid light from spilling outward horizontally toward the highway corridor. Figure 6 to the right is a diagram of the proposed masking shield.

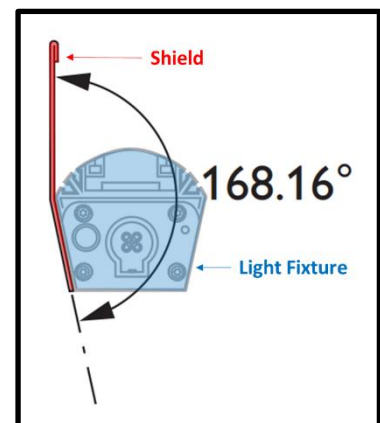

Figure 6: Proposed Light Shield

Roofline Shield. The applicant has incorporated a light shield along the entirety of the roofline in their most recent submittal in order to prevent the upward light from extending beyond the parapet of the building and will be installed along the existing coping of the building in finishes to match the existing façade color. The narrative states that “the proposed light shield would extend the full 180 feet of the roofline and extend 8 inches out from the coping on an 8 inch steep.” The narrative continues to state that the underside of the proposed roofline shield will be black in order to absorb the light. Figure 7 to the right depicts the light rays captured by the roofline shielding in a profile view of the south exterior wall.

Additionally, the light levels mentioned earlier in this report recognize the footcandle level at the top edge of the roofline on the east and west sides of the front elevation as 209. These levels do not extend above the roofline as they are proposed to be captured by the additional shielding.

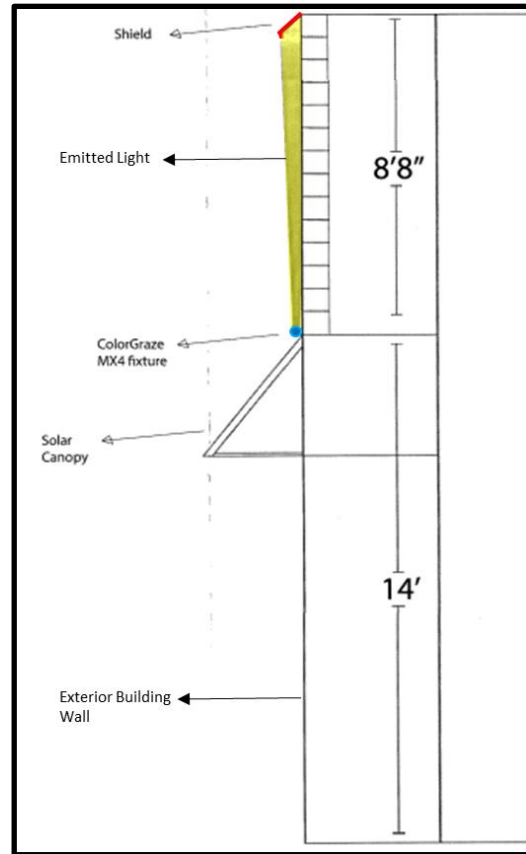

Figure 7: Proposed Roofline Light Shield

References to other prestigious buildings utilizing the light fixtures proposed were noted in the narrative statement as examples of their superior design and high-quality functionality. As previously mentioned, the applicant intends to provide a tasteful appearance and reflect Metro Lighting’s professional image in the lighting industry while also stating that they recognize the UDC’s Architectural Review Design Standards specific to the Chesterfield Valley to “utilize accent lighting and avoid floodlighting for facades of buildings facing I-64/US-40.”

- *Consideration of flexibility in architectural specialty lighting criteria is based on a number of review factors, including, but not limited to, the physical impact of the proposed architectural specialty lighting package, the quality of the proposed architectural specialty lighting package, and mitigation of unfavorable conditions such as excessive lighting, light spillover, height, and other related conditions and potentially negative impacts. However, in no instance shall architectural specialty lighting applications result in light trespass at the property line.*

As seen in the photometric plans provided and the sample imagery of the lighting fixtures while in operation included with the submittal packet, the lights would be pointed upward and shielded from both I-64/US-40 perspective and at the building roofline. The proposed lighting also does not cross any property line.

ARCHITECTURAL REVIEW BOARD INPUT

This project was reviewed by the Architectural Review Board (ARB) on March 14, 2019. At that meeting, the Board recommended approval with the following condition:

- **One color scheme with a maximum of three (3) colors per business day and to remain static from initiating illumination at sunset until ceasing illumination at 11:00 PM.**

The applicant has since revised their Lighting Package submittal to comply with the above recommendation as recognized throughout this staff report. The submittal has also been revised to address concerns regarding sky glow.

DEPARTMENTAL INPUT

Requests for Architectural Specialty Lighting Packages can be permitted if they are found to be architecturally integrated with the building design and harmonious with the surrounding area. Staff is requesting action from the Planning Commission on the Lighting Package proposed for the Metro Lighting location in the MPD Investments subdivision.

MOTION

The following options are provided to the Planning Commission for consideration relative to this application:

- 1) "I move to approve (or deny) the Architectural Specialty Lighting Package for MPD Investments (Metro Lighting) as presented."
- 2) "I move to approve the Architectural Specialty Lighting Package for MPD Investments (Metro Lighting) with the following conditions..." (Conditions may be added, eliminated, altered, or modified).

Attachments: Architectural Specialty Lighting Package Submittal



Metro Lighting Chesterfield Specialty Lighting Application

MPD INVESTMENTS SUBDIVISION
HEATHER KUNST



METRO LIGHTING CHESTERFIELD SPECIALTY LIGHTING APPLICATION
MPD INVESTMENTS SUBDIVISION

Table of Contents

Statement of Design..... 3

Other Building Applications 6

Lot Images & Adjacent Lots 9

Application Photos 12

Coping Shield Proposal Vogel Sheet Metal & Heating, Inc. 15

Coping Shield Sketch Vogel Sheet Metal & Heating, Inc. 16

Aerial Photos 17

Color Elevation Samples for Holidays & Special Events 20

ColorGraze MX4 Powercore Spec sheet 24

Graze Masking Shield Spec sheet 27

Data Enabler Pro Spec sheet 28

Controller Keypad Spec sheet 30

iPlayer 3 Spec sheet 32

ColorPlay 3 User Guide 34

Elevation Sketch Blueprint Attached Separately 36

Roof Line Photometrics Blueprint Attached Separately 37

Drive Photometrics Blueprint Attached Separately 38

STATEMENT OF DESIGN FOR METRO CHESTERFIELD
MPD INVESTMENTS SUBDIVISION

The proposed lighting package for MPD Investments subdivision METRO Lighting / METRO Electric Supply Chesterfield was created to enhance the south facing front façade of 17485 N. Outer 40 in a sophisticated, yet high-tech manner, utilizing the latest in LED technology and design. It also provides both safety and security for our customers and employees and those of the veterinary clinic that share the building. There have been no changes made to the specialty lighting display since the proposal in 2017. We submit that all other lighting shall adhere to the requirements for traditional lighting in the Chesterfield Unified Development Code (UDC) Lighting Standards.

The ColorGraze MX4 LED fixtures proposed are manufactured by Color Kinetics, the leading manufacturer in the world of LED lighting technology and are sold worldwide in large part due to their unmatched innovations and superior design. These fixtures were specifically designed to highlight architectural features ranging from textures and molding details to archways and windows. Our design has two distinct components: the center arch and two flanking sides. Both the center arch and the sides will project a static color and not cycle through the color spectrum. This is simple and sophisticated way to highlight the building's architectural elements in classic manner without drawing excessive attention and remain unobtrusive as noted in UDC 31-04-03C.7.

Some of the world's most prestigious buildings have been outfitted with the Color Kinetics ColorGraze LED lights including the Smithsonian in Washington D.C., the Empire State building in New York, the historic St. Clement Dane Church in London and even the St. Louis Central Public Library in downtown St. Louis¹. Obviously, we want a very tasteful look to reflect our professional image in the lighting industry while also cultivating the architectural appeal in the Chesterfield community. The UDC requires the utilization of accent lighting to illuminate building façades facing I-64/US 40 to convey a high-quality, attractive image at night for travelers along I-64/US40. As a high-end specialty lighting retail establishment, we believe that the color element of the architectural specialty lighting package proposal perfectly highlights the character of our building as specified in UDC 31-04-03.C3.

The 34 LED ColorGraze MX4 fixtures² are permanently mounted on the front façade of the building. Although installed, they are not currently being utilized as we await approval from the City of Chesterfield's Planning Commission. To integrate the lighting into the architecture of the building as specified in UDC 31-04-03.H.6, the low-profile fixtures are mounted directly above the edge of the solar panel awning on each side of the arch, and at the bottom of the center arch façade just above the front entrance. Each fixture is accompanied by a masking shield to prevent any off-site glare.³ This prevents any distraction to drivers and pedestrians as specified in UDC 31-04-03.C.8. The fixtures each measure 48in long x 2.8in wide x 2.7in high x 2.1in deep and are fabricated from an extruded anodized aluminum finish with a clear UV-protected polycarbonate lens⁴. They are mounted at a 90° angle perpendicular to the façade⁵ with multi-positional, constant torque locking hinges⁶. The fixtures in the center archway are mounted at 10 feet above ground level and the fixtures mounted on either side are mounted at a

¹ Other Building Applications pg. 6

² LED ColorGraze MX4 Powercore pg. 24

³ Graze Masking Shield pg. 27

⁴ LED ColorGraze MX4 Powercore pg. 24

⁵ Application Photos pg. 12

⁶ Led ColorGraze MX4 Powercore pg. 24

height of 14 feet above ground level⁷. The light output for each of the four-foot fixtures is 2,172 lumens. The beam angle is 10° x 60° upward and outward respectively.

In order to prevent any night sky light pollution, we are proposing a light shield attached to the coping to prevent glare above the height of the building. The proposed light shield would extend the full 180' of the roof line and extend 8" out from the coping on an 8" steep. It would be fabricated from a 24-gauge galvanized steel and fastened to existing coping. The shield would be finished in a Kynar 25-year coating in a finish which will match the façade color it is attached to. The center will be a matching cream, and the flanking sides a matching grey. The underside of the shield will be finished in black; the black will absorb rather than reflect the captured light. This shield would catch all of the lighting from extending into the skyline and ensure a dark sky agreeable to the Chesterfield Architectural Review Board as well as the Chesterfield Planning Commission. A detailed sketch and proposal are provided in this presentation from Vogel Sheet Metal and Heating, Inc.

The system is controlled and programmed by the iPlayer 3 Controller⁸, the ColorPlay 3 Light Show Authoring Software⁹ component and the programmable Controller Keypad¹⁰ from within the building. Together they allow for complete autonomy of light intensity and color settings. The ColorPlay 3 software configures and controls all lighting settings for the ColorGraze MX4 fixtures including color settings, color range and automatically triggers static color settings based on days of the week, sunset, timer ON / OFF, holidays and so on. The Controller Keypad has eight buttons to instantly trigger pre-programmed lighting selections on the ColorPlay 3 software as well as dimmer controls which can adjust the brightness during use and a master OFF switch. It will be programmed to emit static colors based on the color selections.

We would propose one color scheme with a maximum of three colors per business day in accordance with UDC 31-04-03.C.4 and to remain static from initiating illumination at sunset until ceasing illumination at 11:00 PM in compliance with UDC 31-04-03K.2 of the UDC.

The dashboard of the ColorPlay 3 allows for control of the mapping area which allows programming of the fixture layout in the real world and assign colors. The Fixed Color¹¹ effect displays a single solid color simultaneously on all fixtures in a group. The fixtures would be assigned into 3 groups: Left (14 fixtures) Right (14 fixtures) and Center (6 fixtures).

ColorGraze can also be programmed to display colors which commemorate different events throughout the year. We would propose a static color setting to display for any holiday, and during special events such as a sports team playoff game, etc.

Holiday / Event	Colors
Valentine's Day	Red, White & Pink
St. Patrick's Day	Orange, White & Green
Easter	Yellow, Pink & Blue
Earth Day	Green
Memorial Day	Red, White & Blue
Independence Day	Red, White & Blue

⁷ Elevation Sketch pg. 36

⁸ iPlayer 3 pg. 32

⁹ ColorPlay 3 Setting pg. 34

¹⁰ Controller Keypad pg. 30

¹¹ Fixed Color Effect pg. 34

Labor Day	Red, White & Blue
Prostate Cancer Awareness Month	Light Blue
Breast Cancer Awareness Month	Pink
Columbus Day	Red, White & Green
Small Business Saturday	Blue
Christmas	Red & Green
St. Louis Cardinals	Red & White
St. Louis Blues	Blue & Yellow

Attached you will find the following documents requested:

- Lot & Adjacent Lot Photos¹²
- Night Time Aerial Photos¹³
- Building Elevation Sketch¹⁴
- Roof Line Photometrics¹⁵
- Drive Photometrics¹⁶
- Color Elevations for Holidays and Special Awareness Events¹⁷

We hope that you will see the benefits and the enhancements that this project brings to the building and to the community itself and allow its approval.

Sincerely,

William Frisella
 President
 METRO Lighting / METRO Electric Supply

¹² Lot & Adjacent Lot Photos pg. 9

¹³ Aerial Photos pg. 17

¹⁴ Building Elevation Sketch pg. 36

¹⁵ Roof Line Photometrics pg. 37

¹⁶ Drive Photometrics pg. 38

¹⁷ Sample Static Color Scheme Suggestions pg. 20

Other Building Applications

Lantern Field, Smithsonian,
Washington, D.C.



Empire State Building,
New York, NY

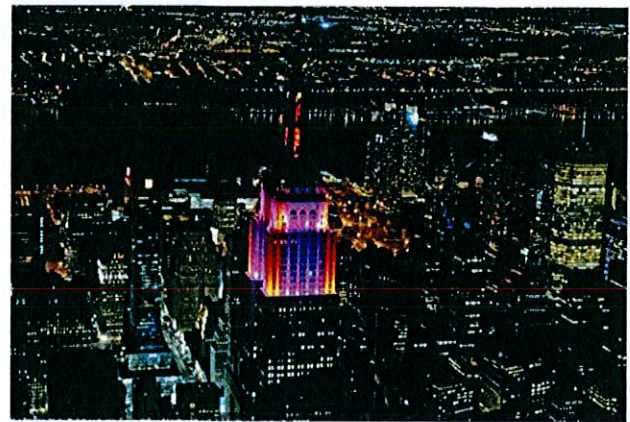

St. Clement Dane Church,
London, UK

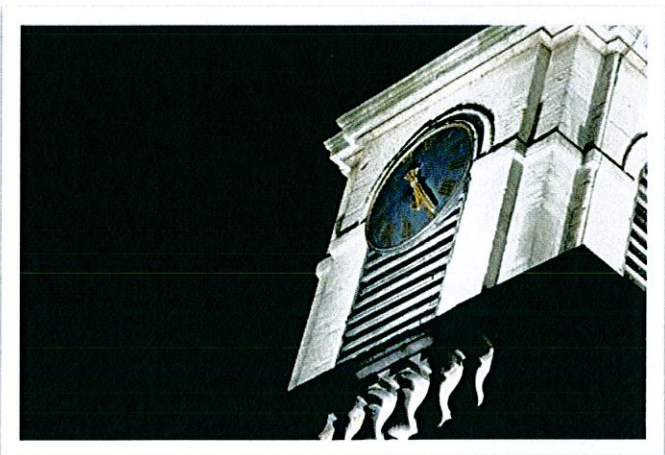
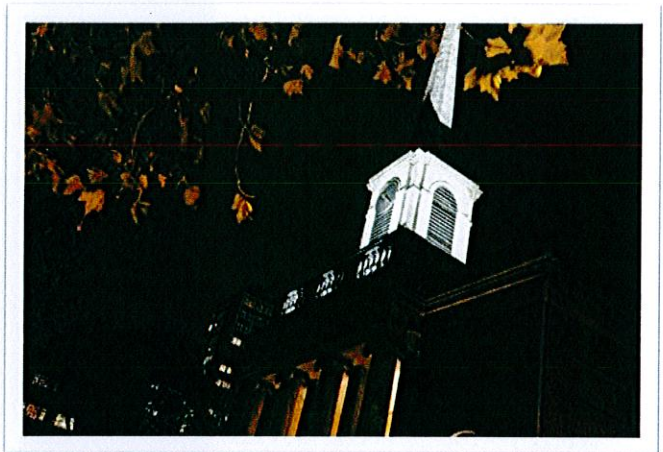
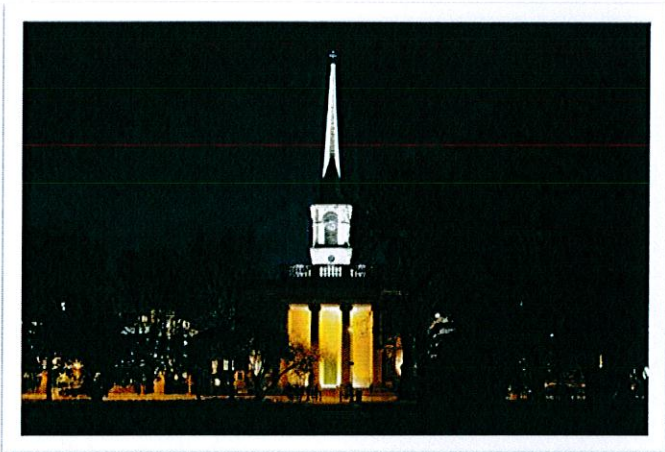

St. Louis Public Library,
Downtown St. Louis, MO

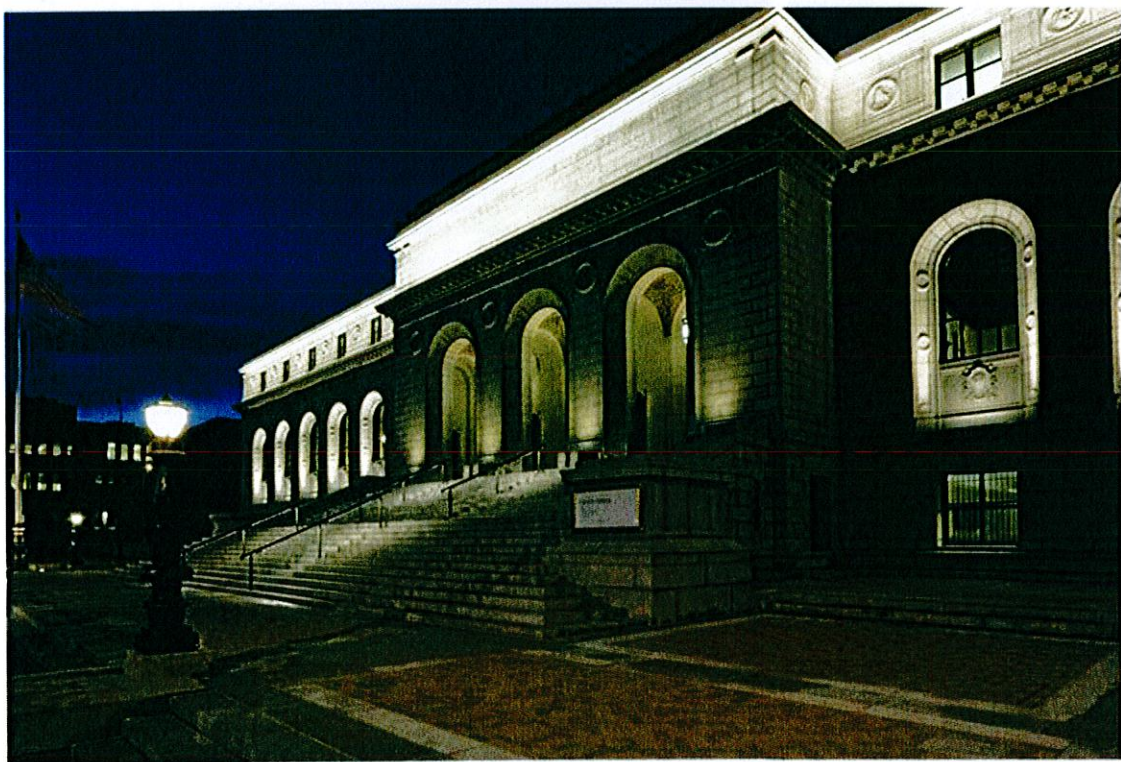

Lot Images & Adjacent Lots

Metro Lighting, Metro Electric Supply, Midwest Veterinary Referral Center, 17485 N Outer 40



Adjacent Lots

Beyond Self Storage,
17481 N Outer 40



Adjacent Lots

Surdyke Motorsports,
17501 N Outer 40



Application Photos

Metro Lighting, Metro Electric Supply, Midwest Veterinary Referral Center, 17485 N Outer 40

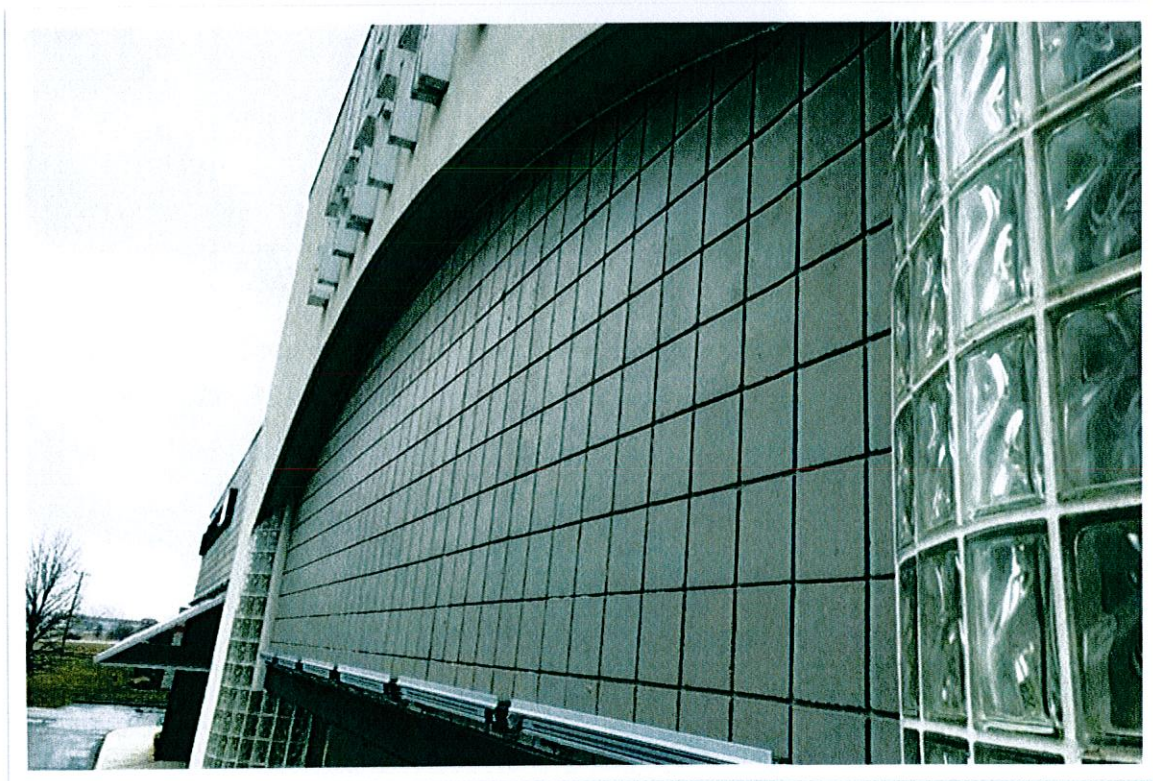

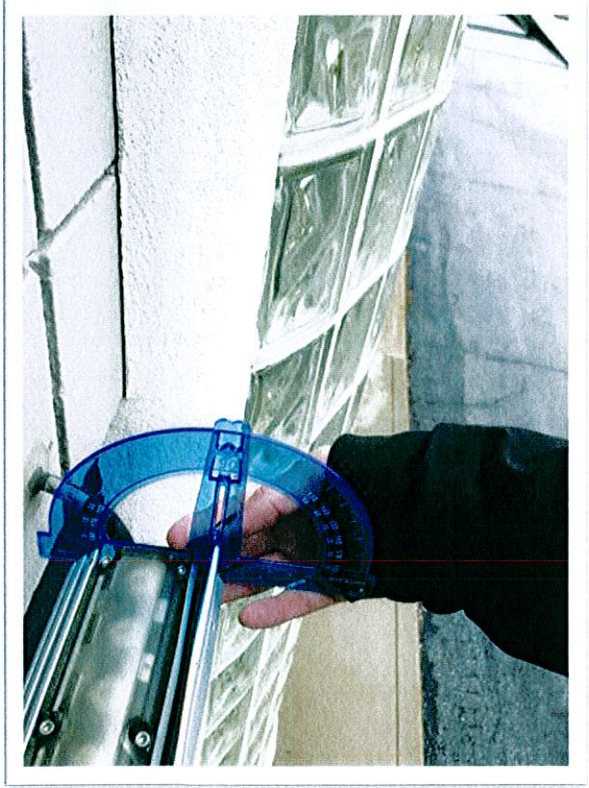

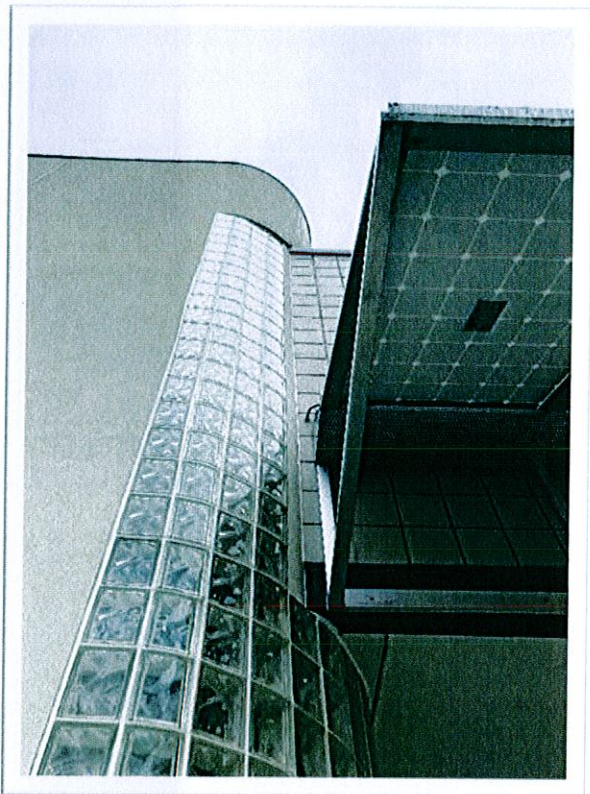
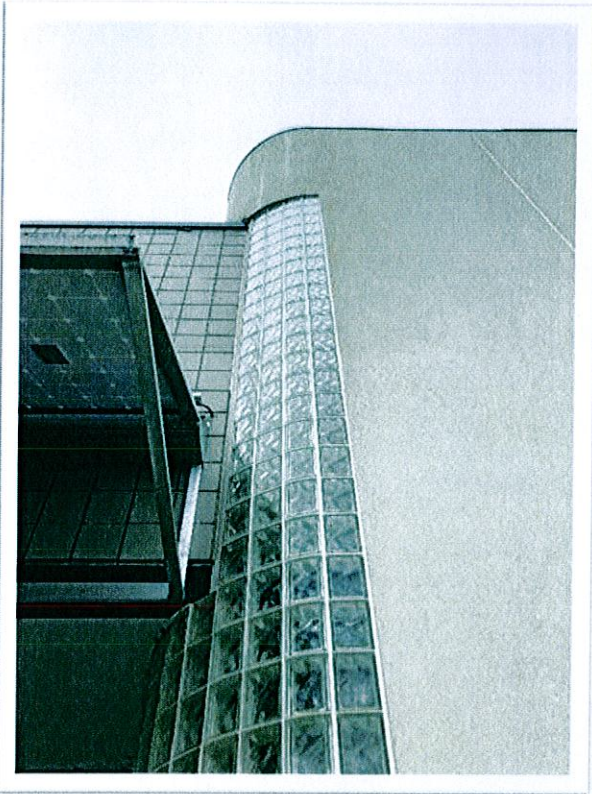



SHEET METAL & HEATING, INC.

1642 Manufacturers Dr. Fenton, MO 63026

P (314) 351-2533 F (314) 351-3253

VOGELHEATING.COM

May 23, 2019

Metro Lighting
17485 N. Outer 40 Rd.
Chesterfield, Mo 63005
Attn: Heather Kunst

RE: Metro Lighting (coping light shield)
Ballwin, MO

We are pleased to submit our quotation for the Architectural Sheet Metal work with the following qualifications:

Furnish Only:

- 180' lft. in 10' sections of a 8" overhang cap shop fabricated from 24ga kynar coated material per attached profile to be fastened by others to existing coping cap (we include 5' gussets)

Exclude:

- any items not specifically spelled out above
- Installation
- Engineering, permits, or stamped sealed calcs or drawings
- custom colors
- structural steel or blocking

Price: \$6,997.00

Sales/Estimating: Rick Sowa

- Quotation is valid for 30 days from date of quotation, unless withdrawn prior to acceptance.
- This proposal shall be binding only when Vogel Sheet Metal & Heating, Inc. and the party addressed in this proposal enter into a mutually acceptable, written Contract/Subcontract Agreement.

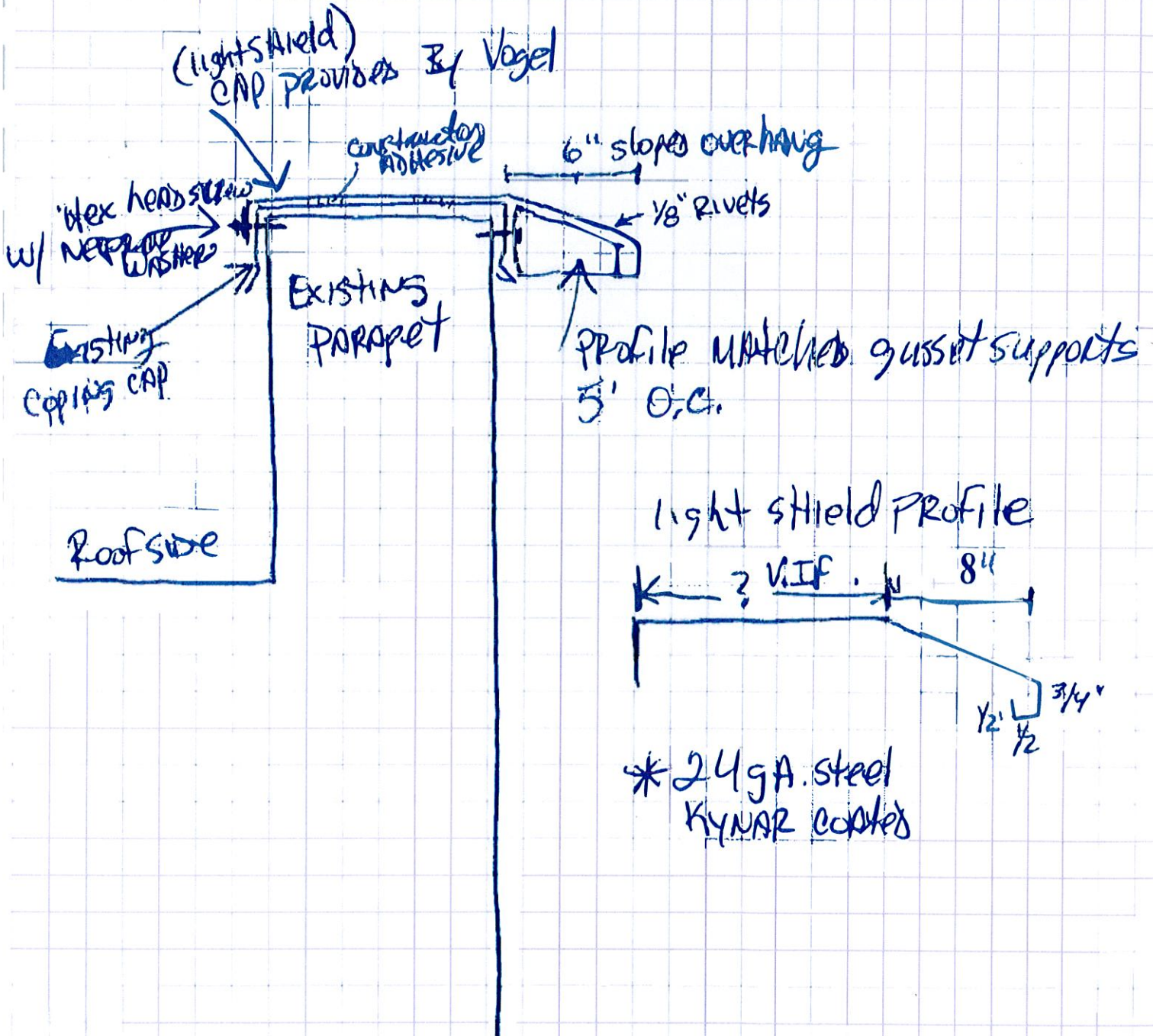

Aerial Photos of Application



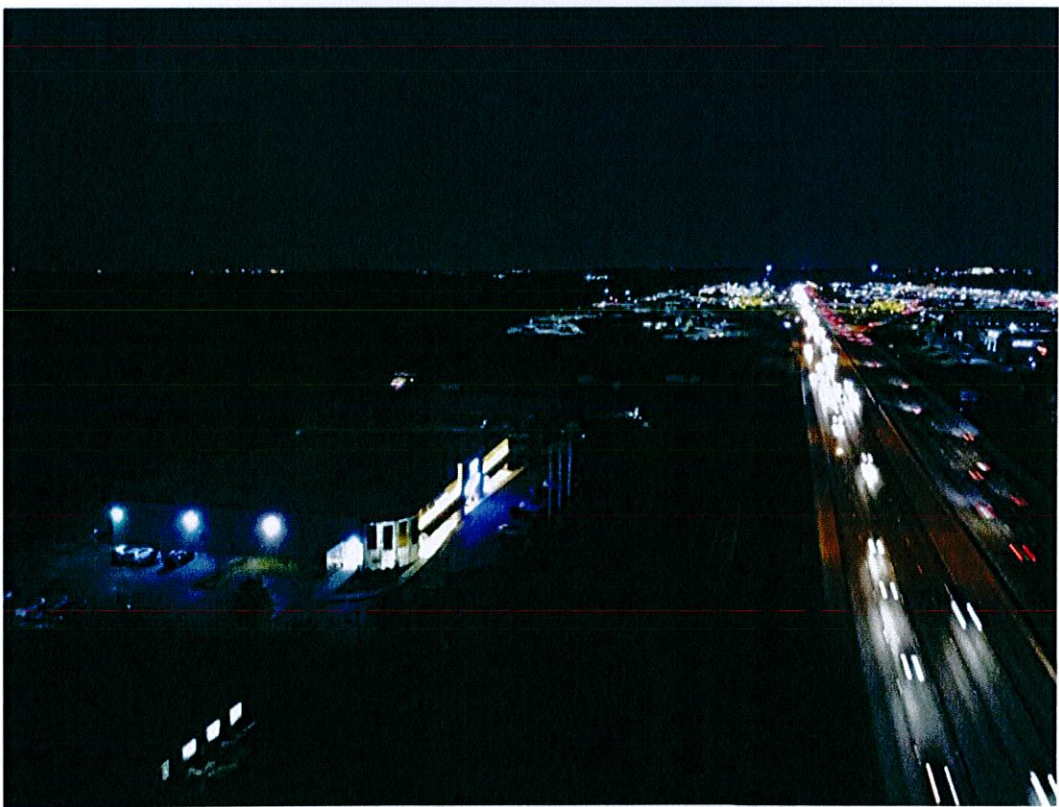



Color Elevation Samples

Valentine's Day

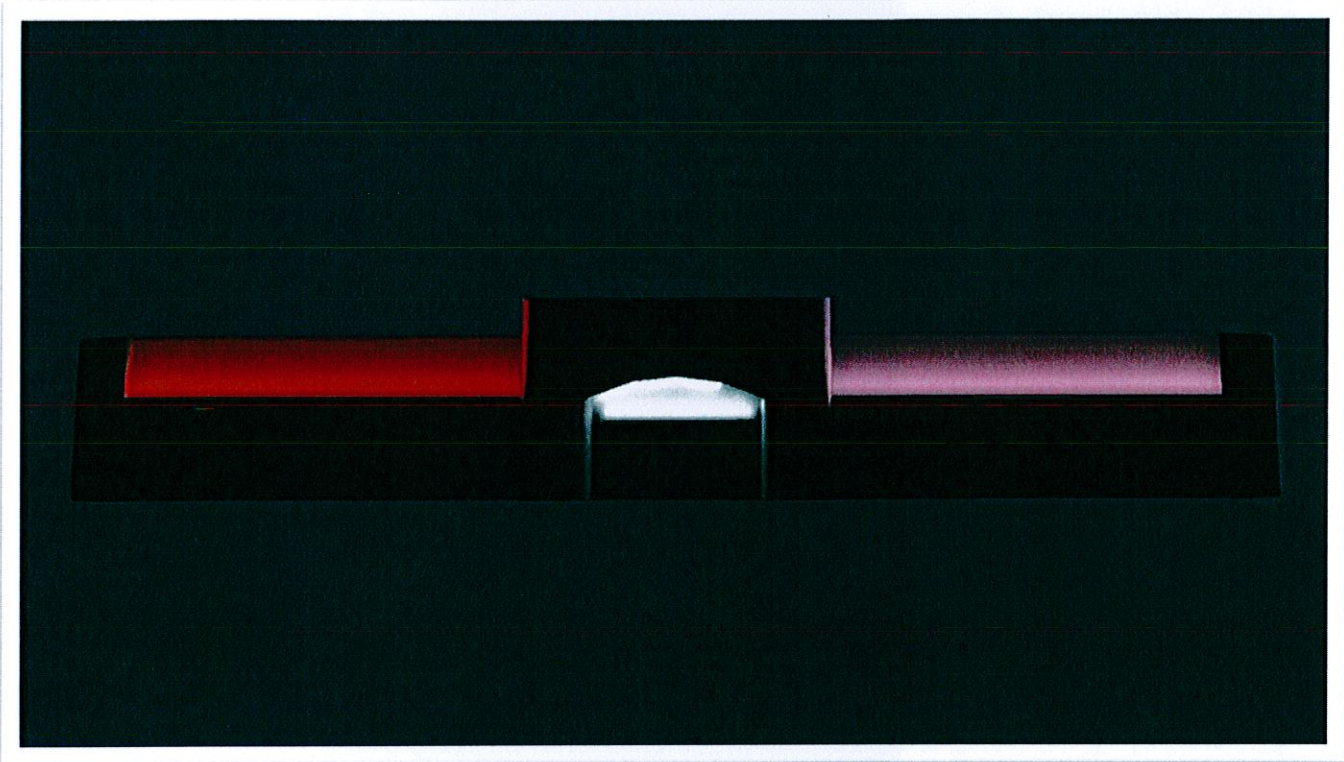

St. Patrick's Day

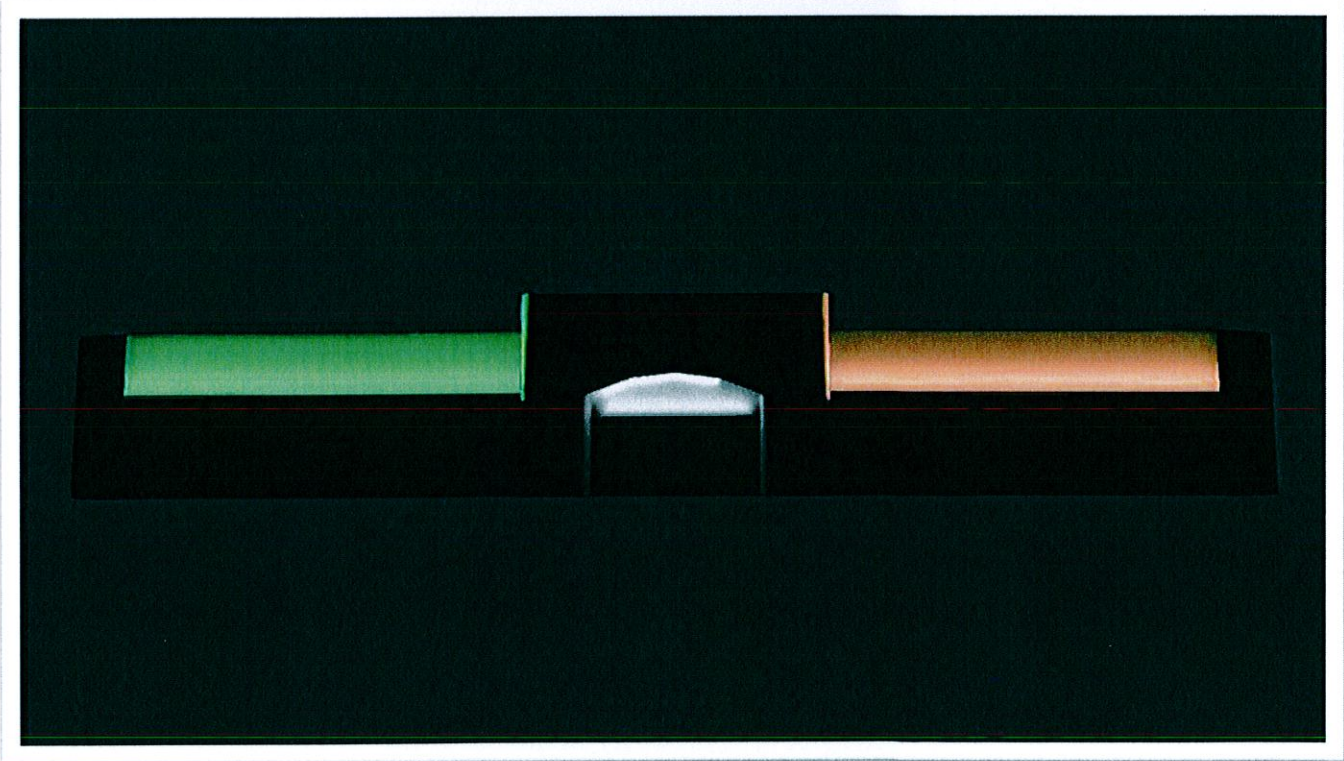

Memorial Day,
Independence Day,
Labor Day

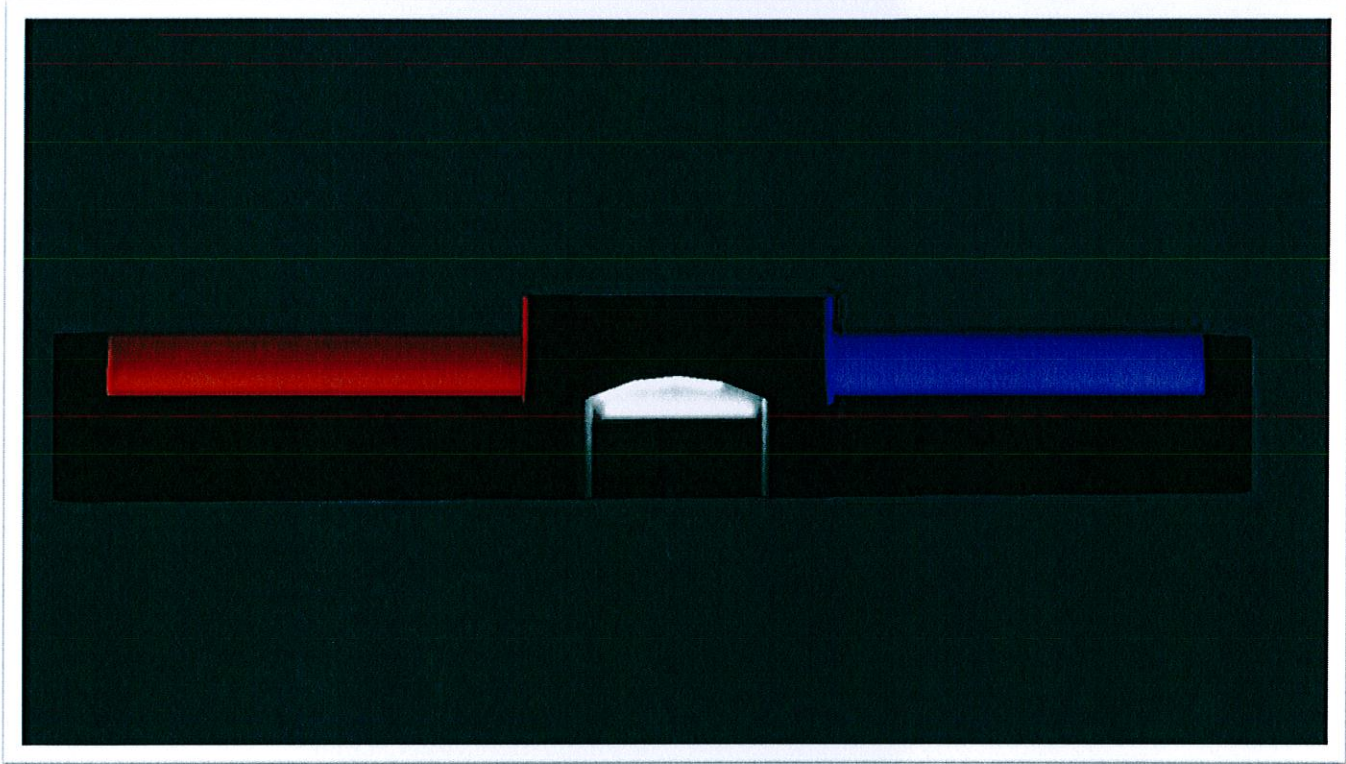

Prostate Cancer Awareness Month

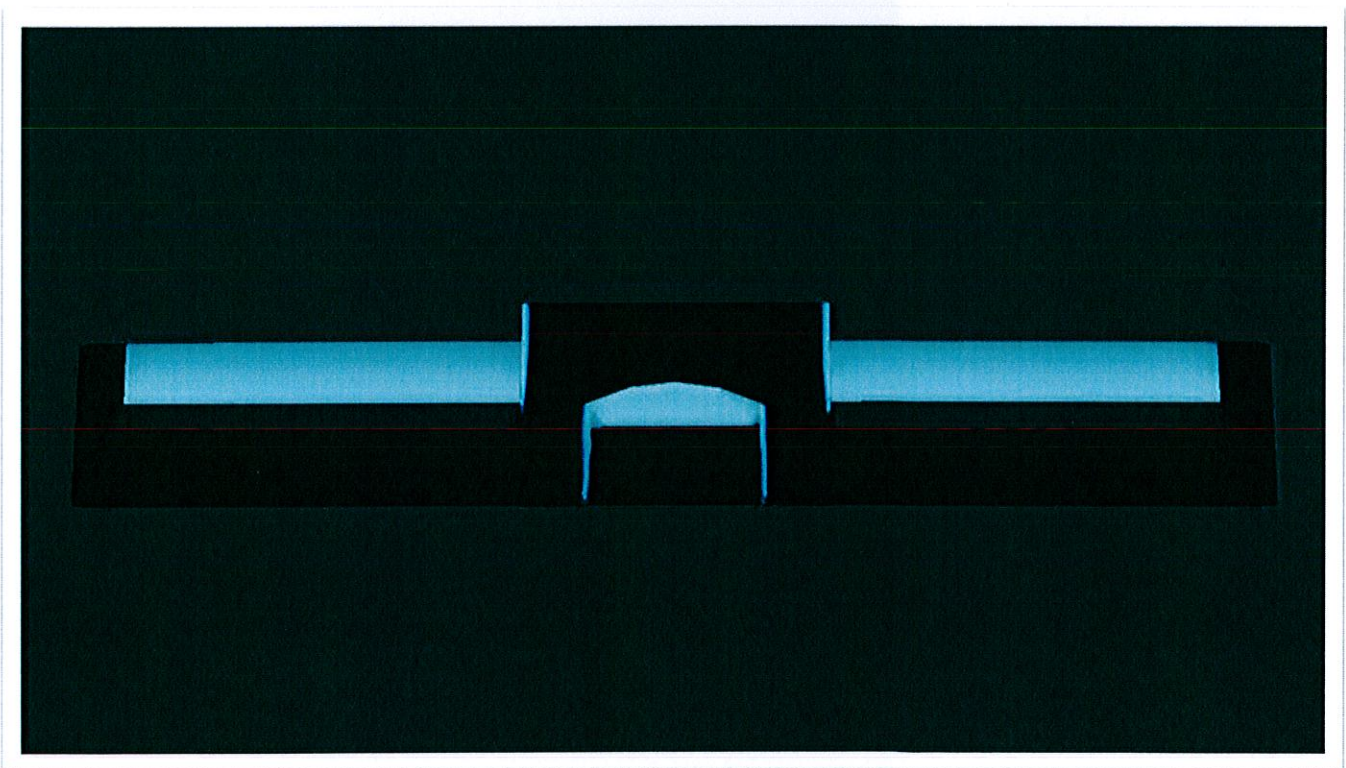

Breast Cancer Awareness Month

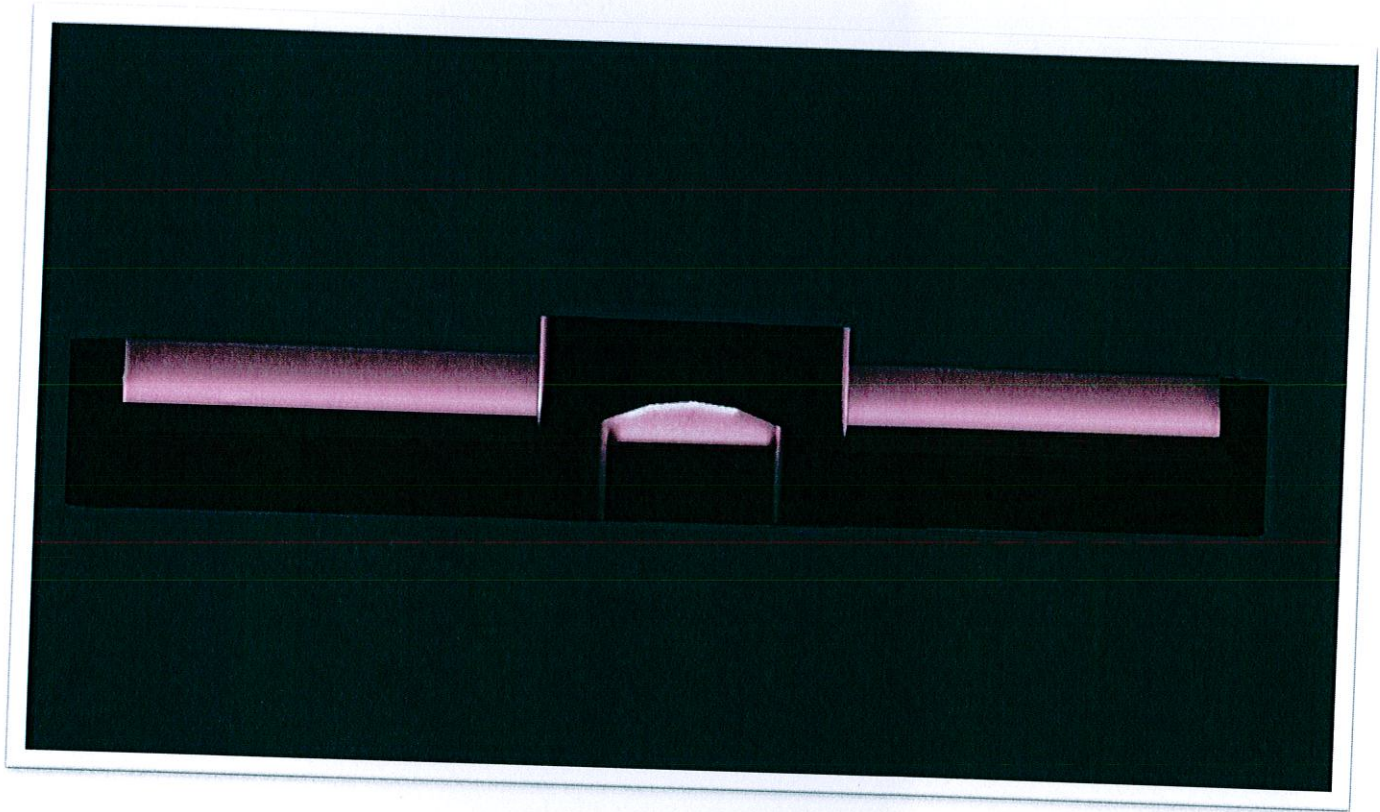

Christmas

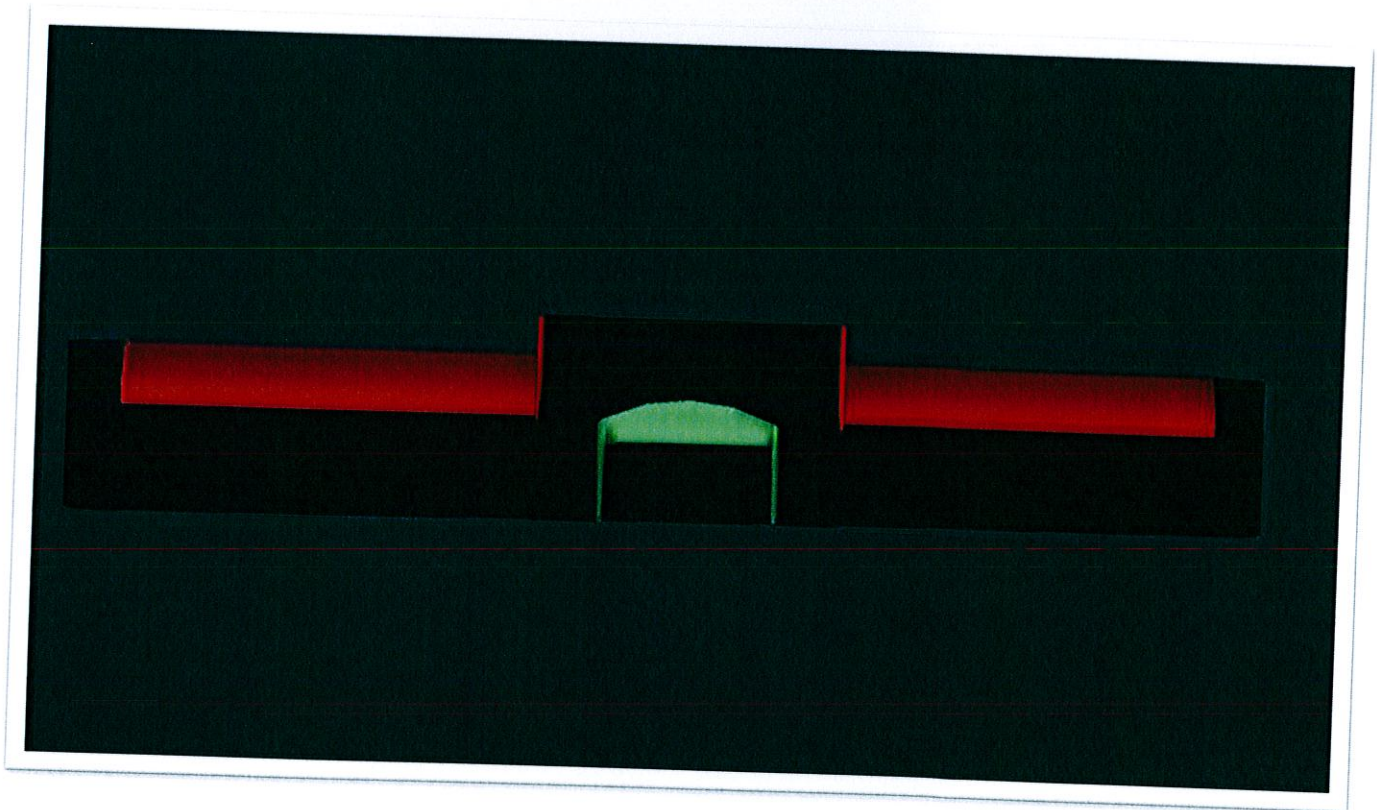

St. Louis Cardinals

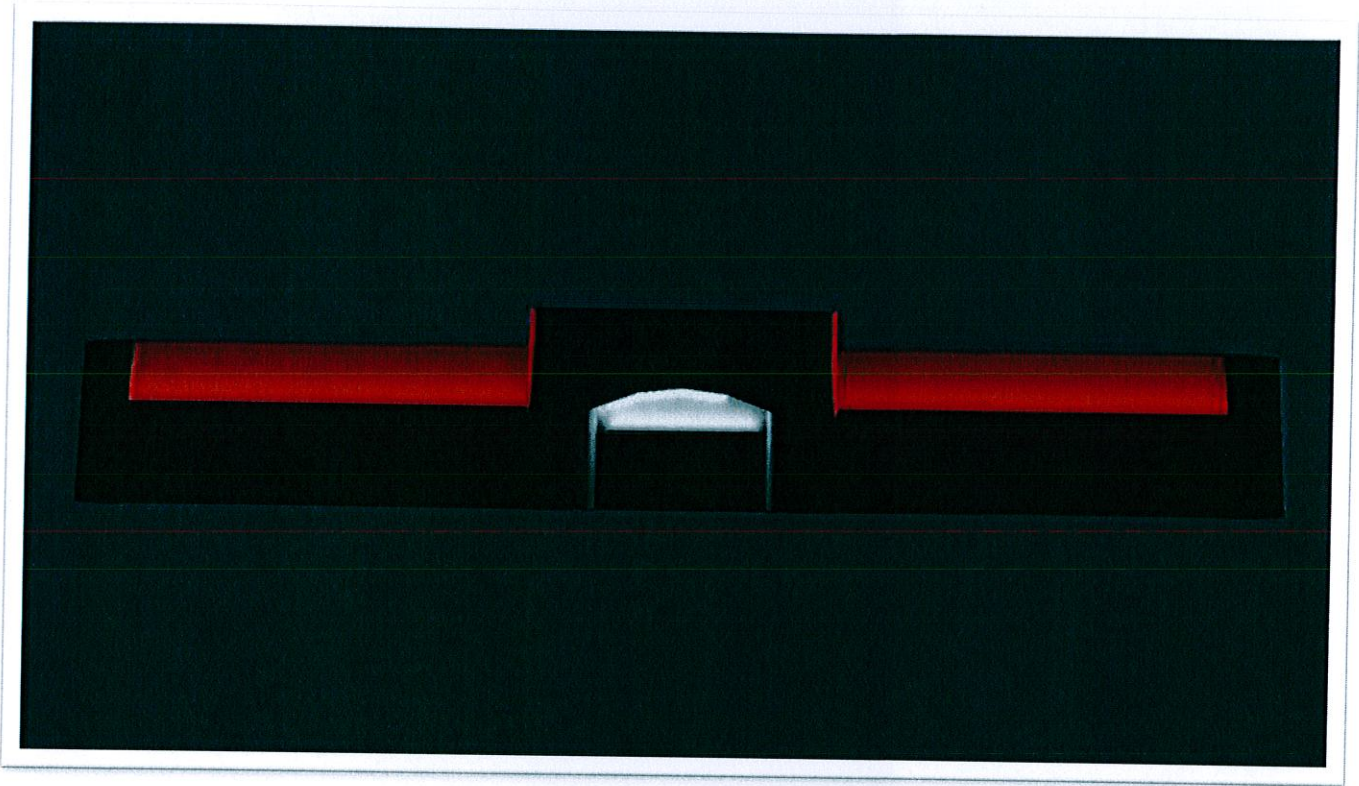

St. Louis Blues

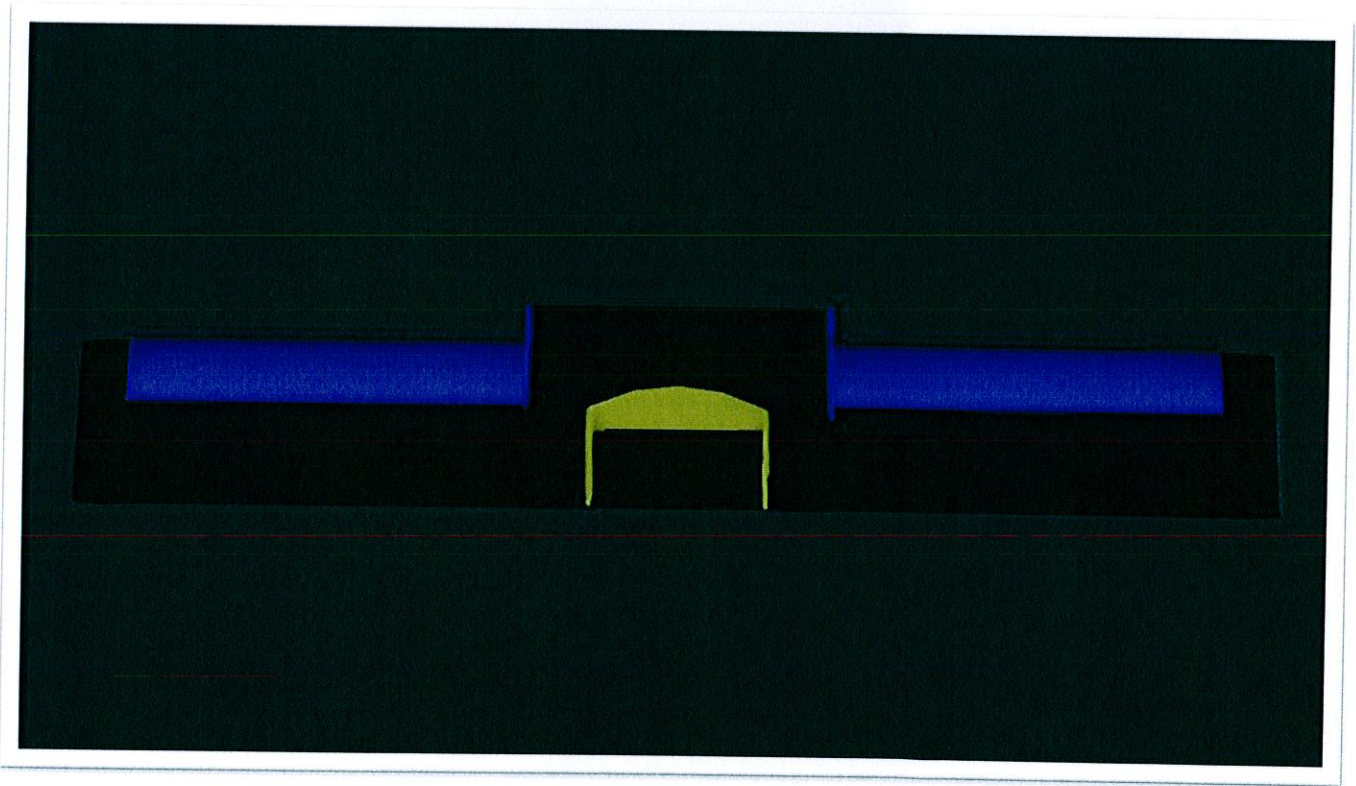

Specifications

Due to continuous improvements and innovations, specifications may change without notice.

Date: _____
 Type: _____
 Firm Name: _____
 Project: _____



ColorGraze MX4 Powercore
 RGBA, 10° x 60° Beam Angle, 1219 mm (4 ft)

Output

Beam Angle	10° x 60°
Lumens†	2,172
Efficacy (lm/W)§§	30.1
LED Channels	Red/Green/Blue/Amber

Electrical

Input Voltage	100 to 277 VAC, auto-ranging, 50/60 Hz
Power Consumption	74 W

(Maximum at full output, steady state)

Control

Interface Data Enabler Pro (DMX or Ethernet)

Control System

Philips Color Kinetics full range of controllers, including Light System Manager, Video System Manager Pro, iPlayer 3, Antumbra iColor Keypad, and ColorDial Pro, or third-party controllers

ActiveSite ActiveSite Ready

Lumen Maintenance

Threshold§	Ambient Temperature	Reported††	Calculated††
L ₇₀	25 °C	70,000	> 100,000
	50 °C	65,000	> 100,000
L ₅₀	25 °C	75,000	
	50 °C	70,000	

Physical

Dimensions 69 x 1219 x 72 mm (2.7 x 48 x 2.85 in)
(Height x Width x Depth)

Weight 4.2 kg (9.3 lb)

Housing Material Extruded anodized aluminium

Lens Clear UV-protected polycarbonate

Luminaire Connections Integral male/female waterproof connectors

Mounting Multi-positional, constant torque locking hinges

Temperature Ranges

-40 to 50 °C (-40 to 122 °F) Operating
 -20 to 50 °C (-4 to 122 °F) Startup
 -40 to 80 °C (-40 to 176 °F) Storage

Vibration Resistance

Not compliant to ANSI C136.31, 3G. Special orders are available to conform to the standard. Please contact your Philips Color Kinetics Lighting Sales rep for custom configurations.

Mechanical Impact IK10

Corrosion Resistance

Complies with ASTM B117 standard with special order. Please contact your Philips Color Kinetics Lighting Sales rep for custom configurations.

Humidity 0 to 95%, non-condensing

Luminaire Run Lengths

To calculate luminaire run lengths and total power consumption for your specific installation, download the Configuration Calculator from www.colorkinetics.com/support/install_tool/

Certification and Safety

Approbation UL/cUL, FCC Class A, CE, PSE, CQC, C-Tick

Environment Dry/Damp/Wet Location, IP66



† 305 mm (1 ft) lumen output measurements comply with IES LM-79-08 testing procedures. 610 mm (2 ft), 914 mm (3 ft), and 1219 mm (4 ft) measurements are estimated based on the 305 mm (1 ft) measurements.

§ Lxx = xx% lumen maintenance (when light output drops below xx% of initial output). All values are given at B10, or the median value where 90% of the LED population is better than the reported or calculated lumen maintenance measurement.

†† Lumen maintenance figures are based on lifetime prediction graphs supplied by LED source manufacturers. Whenever possible, figures use measurements that comply with IES LM-80-08 testing procedures. In accordance with TM-21-11, Reported values represent the interpolated value based on six times the LM-80-08 total test duration (in hours). Calculated values represent time durations that exceed six times the total test duration.

§§ Efficacy measurements are estimated based on the 305 mm (1 ft) measurements.

ColorGraze MX4 Powercore Photometrics 305 mm (1 ft), 10° x 60° beam angle

Photometric data is based on test results from an independent NIST traceable testing lab. IES data is available at www.colorkinetics.com/support/ies.

Beam Angle	10° x 60°
LED	RGBA
Lumens	543
Efficacy (lm/W)	30.1



Illuminance at Distance

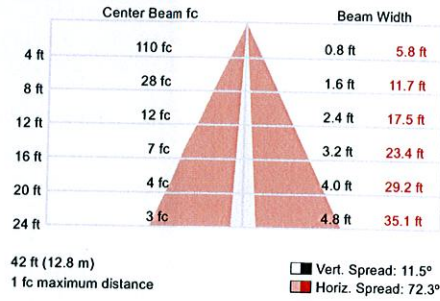

Polar Candela Distribution

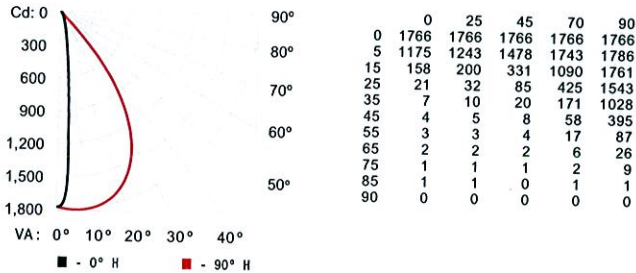

Zonal Lumen

Zone	Lumens	% Fixture
0 - 60	534.7	98.5 %
60 - 90	7.7	1.4 %
0 - 90	542.4	99.9 %

Coefficients of Utilization - Zonal Cavity Method

RCC %:	Effective Floor Cavity Reflectance: 20%											
	80	70	50	30	10	0	80	70	50	30	10	0
RW %:	70	50	30	0	70	50	30	0	50	30	20	0
RCR:	0	119	119	119	119	116	116	116	100	111	111	111
	1	114	111	109	106	111	109	107	94	105	103	101
	2	108	104	100	97	106	102	98	89	99	96	93
	3	103	97	92	89	101	96	91	83	93	89	86
	4	98	91	86	82	97	90	85	78	88	84	81
	5	94	86	81	77	92	85	80	74	83	79	76
	6	90	82	76	72	88	81	75	70	79	75	71
	7	86	77	72	68	85	77	71	66	75	71	67
	8	82	74	68	64	81	73	68	63	72	67	64
	9	79	70	65	61	78	70	64	60	69	64	61
	10	76	67	62	58	75	67	62	58	66	61	58

For lux multiply fc by 10.7

Luminaire and Accessories

Use Item Number when ordering in North America.

Luminaire

ColorGraze MX4 Powercore RGBA, 10° x 60° Beam Angle, 1219 mm (4 ft)	Item Number	Philips 12NC
	423-000002-16	910503704718

Accessories

Inground Enclosure, Outer Box for 1219 mm (4 ft) luminaire	120-000190-07	912400133691
Inground Enclosure, Inner Box for 1219 mm (4 ft) luminaire	120-000190-06	912400133690
Leader Cable with Terminator, UL/cUL, 3 m (10 ft)	108-000055-03	910503704066
Leader Cable with Terminator, UL/cUL, 15.2 m (50 ft)	108-000055-00	910503703137
Leader Cable with Terminator, CE/PSE, 3 m (10 ft)	108-000055-07	910503705065
Leader Cable with Terminator, CE/PSE, 15.2 m (50 ft)	108-000055-06	910503705064
Jumper Cable, UL/cUL, End-to-End	108-000057-00	910503703139
Jumper Cable, UL/cUL, 305 mm (1 ft)	108-000057-03	910503704076
Jumper Cable, UL/cUL, 1.5 m (5 ft)	108-000057-06	910503704079
Jumper Cable, UL/cUL, 3 m (10 ft)	108-000057-09	910503704082
Jumper Cable, CE/PSE, End-to-End	108-000057-01	910503704074
Jumper Cable, CE/PSE, 305 mm (1 ft)	108-000057-04	910503704077
Jumper Cable, CE/PSE, 1.5 m (5 ft)	108-000057-07	910503704080
Jumper Cable, CE/PSE, 3 m (10 ft)	108-000057-10	910503704083
Glare Shield, 1219 mm (4 ft)	120-000081-03	910503700748
Mounting Arm, Short, Gray	120-000201-03	912400135843
Mounting Arm, Medium, Gray	120-000201-04	912400135844
Mounting Arm, Long, Gray	120-000201-05	912400135845
Symmetric Louver, 1219 mm (48 in)	120-000202-03	912400135852
Masking Shield, 1219 mm (48 in)	120-000203-03	912400135860
Power/Data Supplies		
Data Enabler Pro, 3/4 in / 1/2 in K (U.S. trade size conduit)	106-000004-00	910503701210
Data Enabler Pro, PG21/PG13 (metric size conduit)	106-000004-01	910503701211

Copyright © 2018 Philips Lighting Holding B.V. All rights reserved. Chromacore, Chromasic, CK, the CK logo, Color Kinetics, the Color Kinetics logo, ColorBlast, ColorBlaze, ColorBurst, eW Fuse, ColorGraze, ColorPlay, ColorReach, iW Reach, eW Reach, DIMand, EssentialWhite, eW, EvenBalance, iColor, iColor Cove, IntelliWhite, iW, iPlayer, Optibin, and Powercore are either registered trademarks or trademarks of Philips Lighting Holding B.V. in the United States and/or other countries. All other brand or product names are trademarks or registered trademarks of their respective owners. Due to continuous improvements and innovations, specifications may change without notice.

DAS-000130-38 R04 13 June 2018



Philips Color Kinetics
www.philips.com/colorkinetics

Dimensions

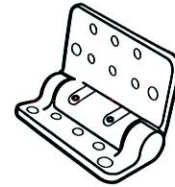
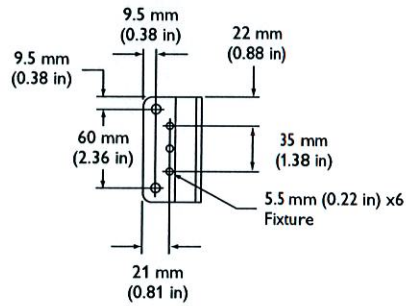
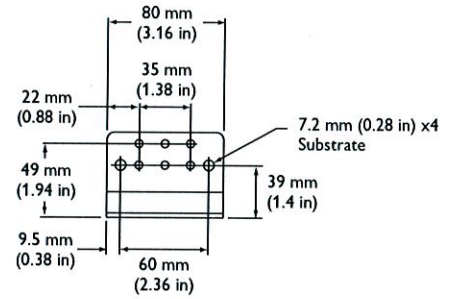
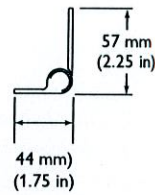
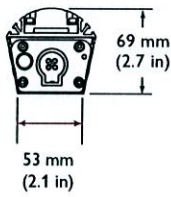
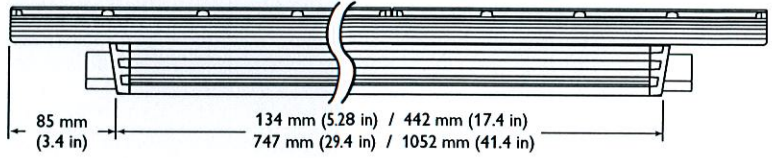
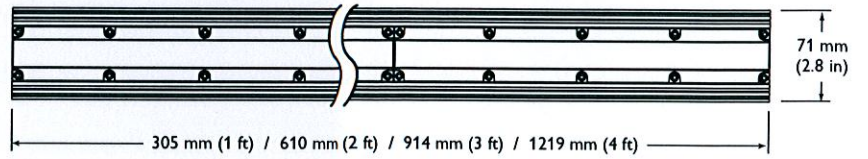
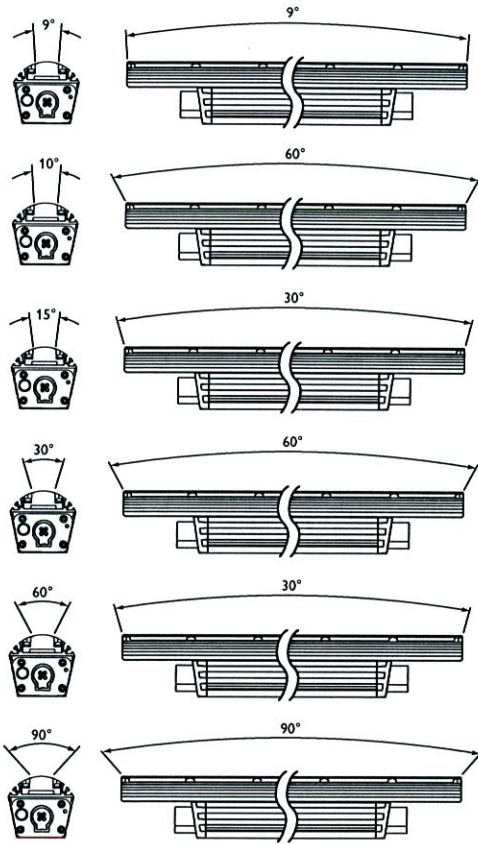

Dimensions

Graze Masking Shield

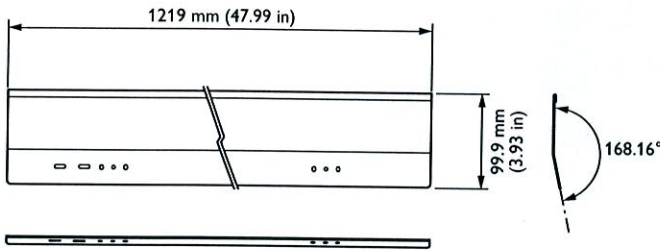

Graze Masking Shield, Mounted

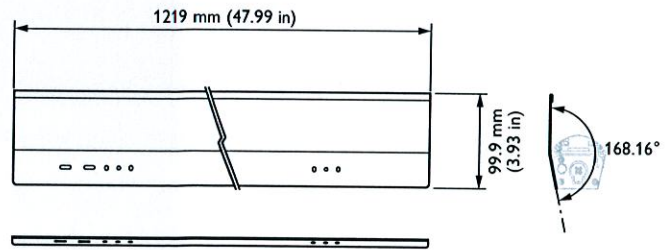

Specifications

Due to continuous improvements and innovations, specifications may change without notice.

Graze Masking Shield, 1219 mm (48 in)

Physical

Dimensions <i>(Height x Width x Depth)</i>	99.9 x 1219 mm x 168.16° (3.93 x 47.99 in x 168.16°)
Weight	0.46 kg (1 lb)
Product Material	Aluminium, gray powder-coated finish
Corrosion Resistance	Complies with ASTM G85 standard

Certification and Safety

Environment	Dry/Damp/Wet Location
-------------	-----------------------

Part numbers

Use Item Number when ordering in North America.

Accessory

	Item Number	Philips 12NC
Graze Masking Shield, 1219 mm (48 in)	120-000203-03	912400135860
Additional Accessories		
Graze Masking Shield, 305 mm (1 ft)	120-000203-00	912400135857
Graze Masking Shield, 610 mm (24 in)	120-000203-01	912400135858
Graze Masking Shield, 914 mm (36 in)	120-000203-02	912400135869
Mounting Arm, Short, Black	120-000201-00	912400135840
Mounting Arm, Medium, Black	120-000201-01	912400135841
Mounting Arm, Long, Black	120-000201-02	912400135842
Mounting Arm, Short, Gray	120-000201-03	912400135843
Mounting Arm, Medium, Gray	120-000201-04	912400135844
Mounting Arm, Long, Gray	120-000201-05	912400135845
Mounting Arm, Short, White	120-000201-06	912400135846
Mounting Arm, Medium, White	120-000201-07	912400135847
Mounting Arm, Long, White	120-000201-08	912400135848
Graze Louver, MX/MX4, 305 mm (1 ft)	120-000202-00	912400135849
Graze Louver, MX/MX4, 610 mm (24 in)	120-000202-01	912400135850
Graze Louver, MX/MX4, 914 mm (36 in)	120-000202-02	912400135851
Graze Louver, MX/MX4, 1219 mm (48 in)	120-000202-03	912400135852
Graze Louver, QLX, 305 mm (1 ft)	120-000202-04	912400135853
Graze Louver, QLX, 610 mm (24 in)	120-000202-05	912400135854
Graze Louver, QLX, 914 mm (36 in)	120-000202-06	912400135855
Graze Louver, QLX, 1219 mm (48 in)	120-000202-07	912400135856

Copyright © 2016 Philips Solid-State Lighting Solutions, Inc. All rights reserved. Chromacore, Chromasic, CK, the CK logo, Color Kinetics, the Color Kinetics logo, ColorBlast, ColorBlaze, ColorBurst, ColorGraze, ColorPlay, ColorReach, iV Reach, eW Reach, DIMand, EssentialWhite, EvenBalance, eW, iColor, iColor Cove, IntelliWhite, iV, iPlayer, Optibin, and Powercore are either registered trademarks or trademarks of Philips Solid-State Lighting Solutions, Inc. in the United States and/or other countries. All other brand or product names are trademarks or registered trademarks of their respective owners. Due to continuous improvements and innovations, specifications may change without notice.



Philips Color Kinetics
www.philips.com/colorkinetics

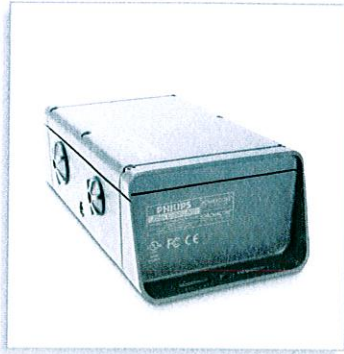

Date: _____ Type: _____

Firm Name: _____

Project: _____

Data Enabler Pro

Integrated data and power for intelligent LED lighting fixtures employing Powercore technology



For information on installation planning, including electrical and data configuration guidelines, view or download the Data Enabler Pro Product Guide from www.philipscolorkinetics.com/lsl/pds/dataenablerpro/

Data Enabler Pro delivers integrated data and power to intelligent color and tunable white LED lighting fixtures employing Powercore technology from Philips Color Kinetics. Data Enabler Pro integrates many of the features of the previous generation of Data Enablers, including Data Enabler DMX, Data Enabler Ethernet, and Data Enabler EO. Data Enabler Pro is the single solution for all intelligent Powercore-based installations, whether DMX or Ethernet, color or white, indoors or outdoors.

- Easy installation — Accessible, clearly labeled terminal block connectors for DMX, Ethernet, line voltage, and fixtures make installation easy. Tethered cover with captive screws ensures convenient removal and replacement.
- Supports fixtures employing Powercore technology — Powercore technology rapidly, efficiently, and accurately controls power output to LED lighting fixtures directly from line voltage. Philips Data Enabler Pro merges line voltage and control data and delivers them to Powercore fixtures over a single cable, dramatically simplifying installation and lowering total system cost.
- On-board diagnostics — On-board indicator LEDs provide visual feedback for normal operation, Ethernet connection detection, and Ethernet and DMX data transmission.
- Full support for DMX and Ethernet — Provides inputs and outputs for both DMX and Ethernet, allowing you to connect multiple Data Enabler Pro devices in series. Also provides an Ethernet output terminal for eW Accent MX Powercore and iColor Accent MX Powercore support.

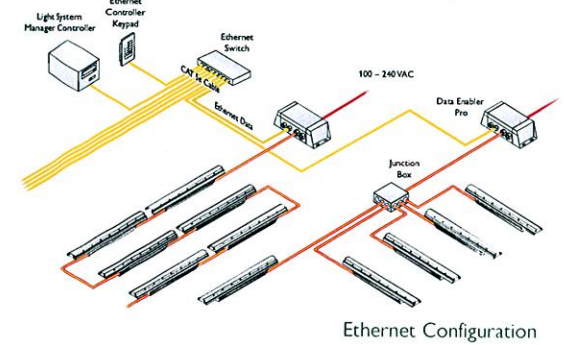
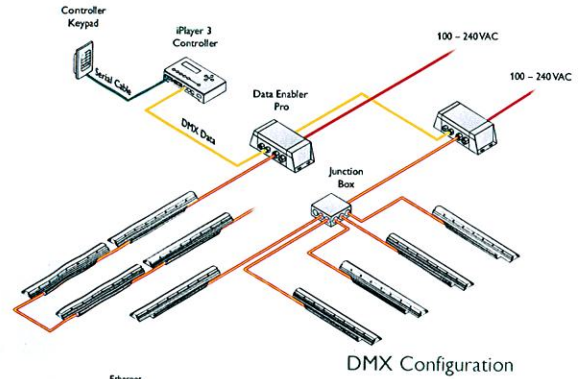

- Outdoor-rated for use in damp and wet environments — Data Enabler Pro offers superior leakage protection in a cast aluminum, IP66-rated enclosure.
- Multiple conduit entries — Data Enabler Pro conduit entries accommodate NPT conduit in US trade sizes of 1/2 in and 3/4 in, or metric sizes of PG13 and PG21.
- Universal power input range — Data Enabler Pro automatically senses mains voltages ranging from 100 – 277 VAC, and passes mains voltages through to all connected lights.
- Designed for maximum energy efficiency — Data Enabler Pro consumes just 20 W maximum. Optional power-saving modes automatically cut power to attached lights when lights are off for a configurable number of minutes.

PHILIPS

Specifications

Due to continuous improvements and innovations, specifications may change without notice.

Item	Specification	Details
Electrical	Input Voltage	100 – 277 VAC*, auto-ranging, 50 / 60 Hz
	Maximum Input Current	16.5 A maximum
	Power Consumption	20 W maximum
	Load Current	16 A maximum
Connections	Power Input	3-wire PC terminal block connector†
	Power / Data Output	4-wire PC terminal block connector†
	DMX Input / Output	4-wire IDC terminal block connector (eW Accent MX Powercore and iColor Accent MX Powercore only)‡
	DMX Input / Output	Double-pair, double-entry IDC connectors‡
	Ethernet Input / Output	Double-pair, double-entry IDC connectors‡
Physical	Dimensions (Height x Width x Depth)	3.4 x 10.5 x 5.4 in (87 x 267 x 138 mm)
	Weight	5.4 lb (2.4 kg)
	Construction	Cast aluminum enclosure with slots for surface mounting
	Finish	Powder-coated industrial gray matte
	Threaded Openings	3/4 in NPT for power / 1/2 in NPT for data (US trade) PG21 for power / PG13 for data (metric)
	Temperature Ranges	-40° – 122° F (-40° – 50° C) Operating -4° – 122° F (-20° – 50° C) Startup -40° – 176° F (-40° – 80° C) Storage
	Humidity	0 – 95%, non-condensing
	Cooling	Convection
	Heat Dissipation	20 W
	Data Input Source	Philips full range of controllers, third-party DMX controllers, or KiNET-compatible§ third-party Ethernet controllers
Certification and Safety	Certification	UL / cUL, FCC Class A, CE, C-Tick
	Environment	Dry / Damp / Wet Location, IP66

* Verify that the line voltage is appropriate for the lighting fixtures in your installation. See a specific fixture's documentation for supported line voltages.



† PC terminal block connectors accept recommended wire sizes from 8 – 18 AWG (8.37 – 0.823 mm²).

‡ IDC connectors accept wire sizes from 22 – 26 AWG (0.326 – 0.129 mm²).

§ KiNET is the Ethernet lighting protocol from Philips Color Kinetics.

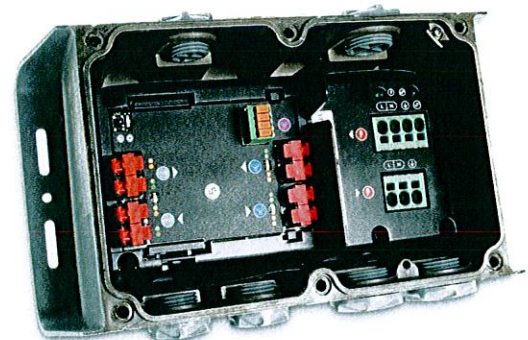
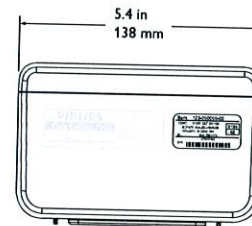
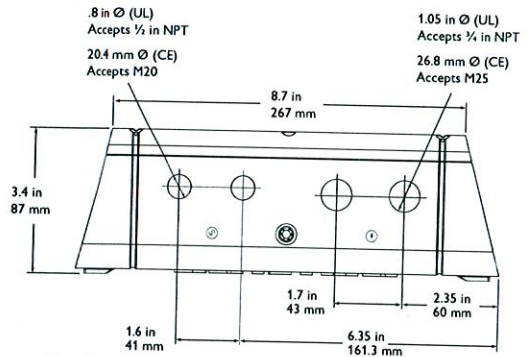
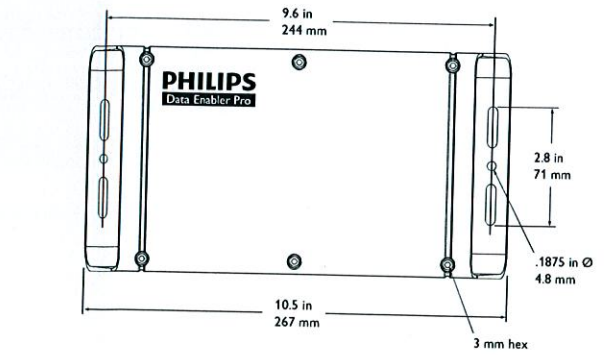

Ordering Information

Item	Type	Item Number	Philips 12NC
Data Enabler Pro	3/4 in / 1/2 in NPT (US trade size conduit)	106-000004-00	910503701210
	PG21 / PG13 (metric size conduit)	106-000004-01	910503701211

Use Item Number when ordering in North America.



Philips Color Kinetics
3 Burlington Woods Drive
Burlington, Massachusetts 01803 USA
Tel 888.385.5742
Tel 617.423.9999
Fax 617.423.9998
www.philipscolorkinetics.com

Copyright © 2010 – 2012 Philips Solid-State Lighting Solutions, Inc. All rights reserved. Chromacore, Chromasic, CK, the CK logo, Color Kinetics, the Color Kinetics logo, ColorBlast, ColorBlaze, ColorBurst, eW Fuse, ColorGraze, ColorPlay, ColorReach, iW Reach, eW Reach, DIMand, EssentialWhite, eW, iColor, iColor Cove, IntelliWhite, iW, iPlayer, Optibin, and Powercore are either registered trademarks or trademarks of Philips Solid-State Lighting Solutions, Inc. in the United States and / or other countries. All other brand or product names are trademarks or registered trademarks of their respective owners. Due to continuous improvements and innovations, specifications may change without notice.

DAS-000052-01 R06 10-15

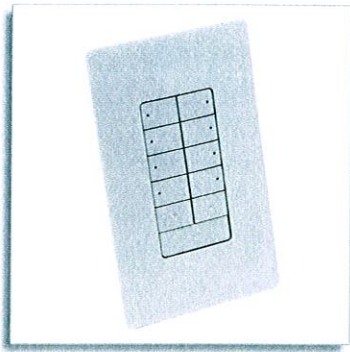

Date: _____ Type: _____

Firm Name: _____

Project: _____

Controller Keypad

Wall-mounted keypad for triggering iPlayer 3 light shows

Controller Keypad is a convenient and elegant user interface to iPlayer 3, a compact DMX lighting controller that stores and plays back custom ColorPlay 3 light shows. iPlayer 3 and Controller Keypad integrate to provide push-button playback of up to eight shows per keypad.

- Full set of lighting controls — Each keypad instantly and conveniently triggers up to eight iPlayer 3 light shows. Onboard indicator lamps identify the current show. Dimmer controls adjust the brightness of light fixtures during playback, and a master OFF switch turns all show lights off.
- Simple installation — Mounts in a standard U.S. single-gang wall box. Uses a single serial cable to connect with iPlayer 3.
- Standard support for two Controller Keypads within a single installation — Standard configuration allows you to easily install two keypads in a single iPlayer 3 installation, for control of up to 16 shows. With advanced instructions, you can install up to eight keypads in a single installation, for control of up to 64 total shows.
- Compact design with sleek Decora style faceplate — Compact design uses wall space efficiently. Industry standard Decora style faceplate hides mounting hardware for a clean look that blends with a variety of architectural styles.

For detailed product information, please refer to the Controller Keypad Product Guide at www.philipscolorkinetics.com/ls/controllers/controllerkeypad/

Typical iPlayer 3 Installation with Controller Keypad

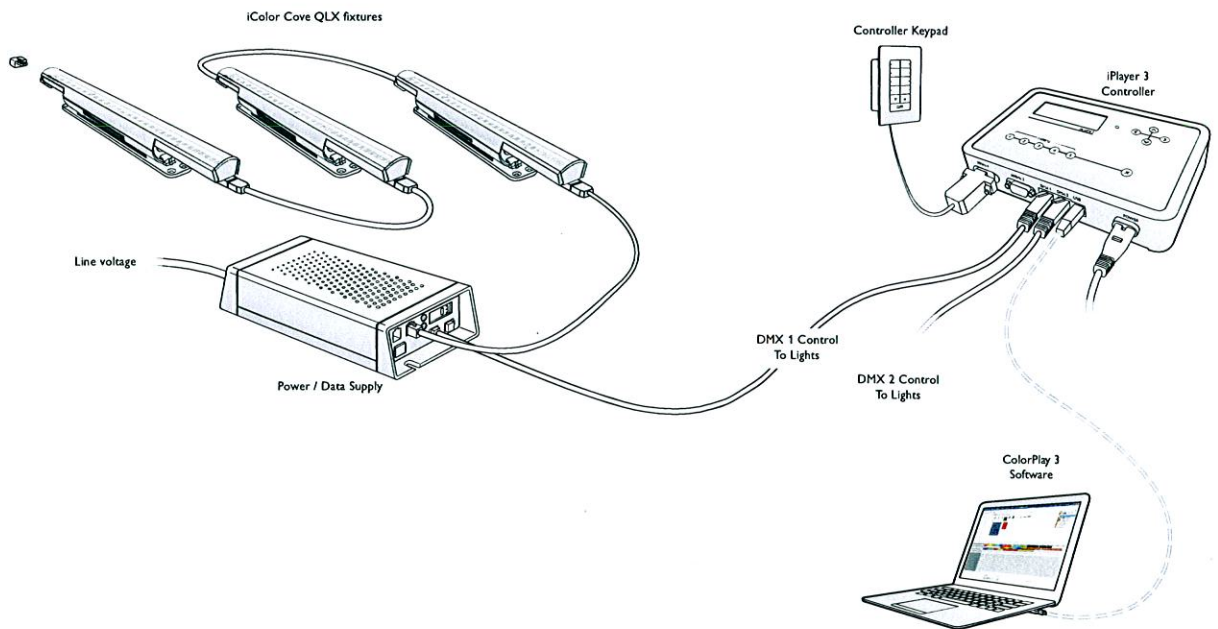

Specifications

Due to continuous improvements and innovations, specifications may change without notice.

Item	Specification	Details
Control	Serial	+5VDC @ 50 mA, from iPlayer 3 Controller
Physical	Dimensions (Height x Width x Depth)	4.7 x 2.9 x .93 in (119 x 74 x 24 mm)
	Weight	3 oz (85 g)
	Housing	Medium matte white plastic Decora style faceplate Mounts in single-gang wall box
	Temperature Ranges	14° – 104° F (-10° – 40° C) Operating 14° – 122° F (-10° – 50° C) Startup -40° – 176° F (-40° – 80° C) Storage
	Humidity	0 – 95%, non-condensing
	Connector / Cable	Serial cable, 20 ft (6.1 m) included Length of up to 50 ft (15.2 m) supported
	Certification	CE
Environment	Indoor, Dry	



Controller Keypad and Accessories

Item	Item Number	Philips 12NC
Controller Keypad	103-000020-00	910503700223
iPlayer 3	North America Power Cord	103-000019-00 910403327101
	Europe Power Cord	103-000019-01 910503700392
	China (CCC) Power Cord	103-000019-02 910503700738

Use Item Number when ordering in North America.

Front

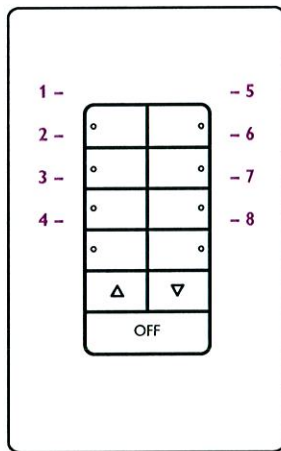

Show buttons
Dimmer controls
Turns all show lights off

Back

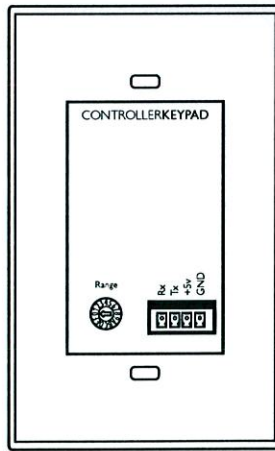

Dimensions

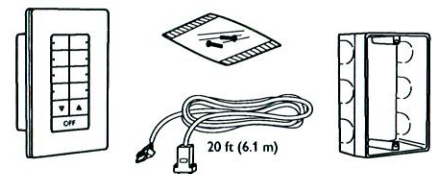
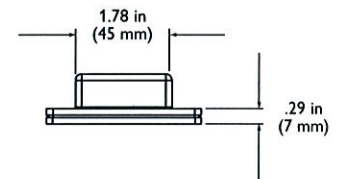
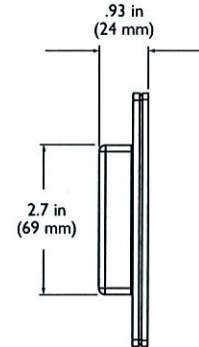
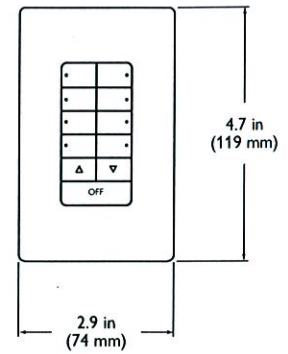

Controller Keypad is part of a complete system that includes:

- iPlayer 3 (including ColorPlay 3) for configuring the keypad and for assigning shows to each keypad trigger.
- The provided 20 ft (6.1 m) serial cable, or a custom serial cable of no longer than 50 ft (15.2 m).

Included in the box

- Controller Keypad
- 20 ft (6.1 m) serial cable
- Standard single-gang wall box for use outside of North America
- (2) self-threading flat-head countersunk M2.5 screws
- Decora style faceplate

For detailed product information, please refer to the Controller Keypad Product Guide at www.philipscolorkinetics.com/ls/controllers/iplayer3/



Philips Color Kinetics
3 Burlington Woods Drive
Burlington, Massachusetts 01803 USA
Tel 888.385.5742
Tel 617.423.9999
Fax 617.423.9998
www.philipscolorkinetics.com

Copyright © 2008 – 2012 Philips Solid-State Lighting Solutions, Inc. All rights reserved. Chromacore, Chromasic, CK, the CK logo, Color Kinetics, the Color Kinetics logo, ColorBlast, ColorBlaze, ColorBurst, eW Fuse, ColorGraze, ColorPlay, ColorReach, iW Reach, eW Reach, DIMand, EssentialWhite, eW, iColor, iColor Cove, IntelliWhite, iW, iPlayer, Optibin, and Powercore are either registered trademarks or trademarks of Philips Solid-State Lighting Solutions, Inc. in the United States and / or other countries. All other brand or product names are trademarks or registered trademarks of their respective owners. Due to continuous improvements and innovations, specifications may change without notice. DAS-000016-01 R05 04-12



Date: _____ Type: _____

























Firm Name: _____

Project: _____

iPlayer 3

Author, configure, and control dynamic LED light shows for DMX lighting networks

ColorPlay 3 Effects

-  Fixed Color
-  Cross Fade
-  Color Wash
-  Chasing
-  Chasing Node
-  Sweep
-  Sweep Node
-  Sparkle
-  Streak
-  Spiral
-  Burst
-  Random Color
-  Image Fade
-  Video
-  Text
-  Strobe
-  Ripple
-  Particle
-  Colored Bars
-  Constant Modifier
-  Wave Modifier
-  Fade In Fade Out Modifier
-  RGB Range Modifier
-  Perlin Noise Modifier

iPlayer 3 controller is a compact yet powerful show storage and playback device capable of delivering light shows to installations with up to 340 unique light addresses. Packaged with ColorPlay 3 light show authoring software, iPlayer 3 is designed to add new levels of sophistication and flexibility to your lighting installations while eliminating the need for expensive lighting boards and technical programming expertise.

- Easy to use — With factory preset shows, custom show-authoring capabilities, an intuitive LCD interface, removable SD card storage, and onboard light addressing features, iPlayer 3 enables you to spend more time on the creative aspects of lighting design and less time on setup.
- Packaged with ColorPlay 3 light show authoring software — ColorPlay 3 gives you the flexibility to create and manage light shows using fully customizable effects, multi-track editing, timeline layering, and transition styles.
- Designed for use with the optional Controller Keypad — Controller Keypad is a wall-mounted user interface providing instant pushbutton playback of up to eight light shows.

- Supports the optional AuxBox expansion device — AuxBox automatically triggers up to eight iPlayer 3 light shows using any remote triggering device with a dry-contact closure. Via the AuxBox, you can trigger light shows by motion sensors, 3rd party control or sensor systems, and more.
- Control two DMX universes — iPlayer 3 has two DMX output ports, each controlling a universe of 512 DMX channels.
- Automate show playback — Set alarms to automatically trigger show playback based on a specific date, day of the week, weekdays, weekends, or an astronomical event, such as sunrise or sunset.

For detailed product information, please refer to the iPlayer 3 Product Guide at www.philipscolorkinetics.com/lis/controllers/iplayer3/

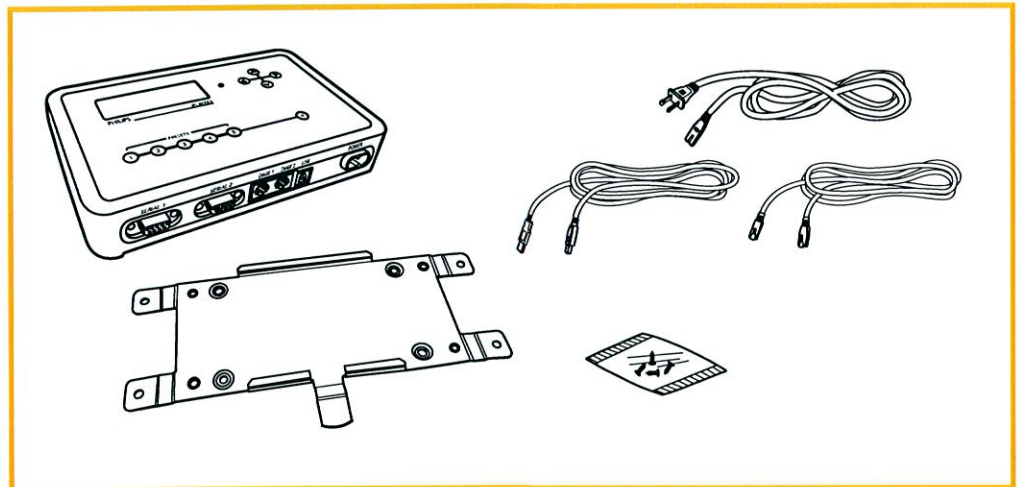

Specifications

Due to continuous improvements and innovations, specifications may change without notice

Item	Specification	Details
Capability	Capacity	2 universes of 512 DMX addresses each
Electrical	Input Voltage	100 – 240 VAC, 50 / 60 Hz, 5 W
	Computer Interface	USB 2.0
Control	External / Auxiliary Interface	Two DMX512 RJ45 ports Two RS-232 9-pin serial ports
	Data Storage	Removable Secure Digital Card drive
Physical	Dimensions (Width x Depth x Height)	8.2 x 5.4 x 1.3 in (209 x 137 x 33 mm)
	Weight	1.2 lb (0.54 kg)
	Housing	Polycarbonate
	Operating Temperature	14° – 104° F (-10° – 40° C)
	Humidity	0 – 95%, non-condensing
Certification and Safety	Certification	UL / cUL, FCC Class B, CE, CQC, C-Tick
	Environment	Dry Location, IP20

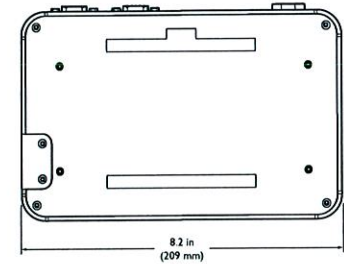
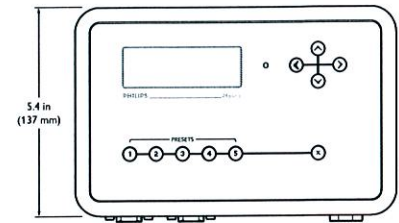

Software Requirements

System Requirements	Specification	PC	Mac
Software	Operating System	Windows 2000 / XP / Vista	Mac OS 10.4 or greater
	Memory	512 MB RAM	512 MB RAM
	Disk space	60 MB free disk space	60 MB free disk space

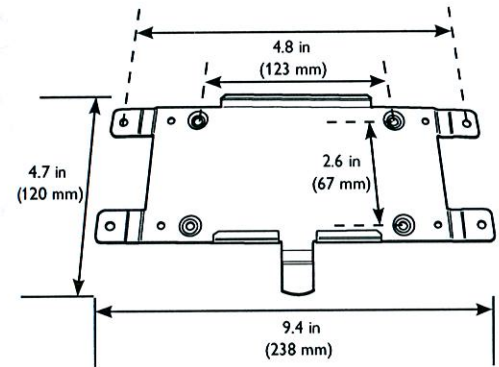

iPlayer 3 and Accessories

Item	Type	Item Number	Philips 12NC
	North America Power Cord	103-000019-00	910403327101
iPlayer 3	Europe Power Cord	103-000019-01	910503700392
	China (CCC) Power Cord	103-000019-02	910503700738
Controller Keypad	DB-9 Serial	103-000020-00	910503700223
AuxBox	DB-9 Serial	103-000021-01	910503702433

Use Item Number when ordering in North America.

✳ For detailed product information, please refer to the iPlayer 3 Product Guide at www.philipscolorkinetics.com/ils/controllers/iplayer3/

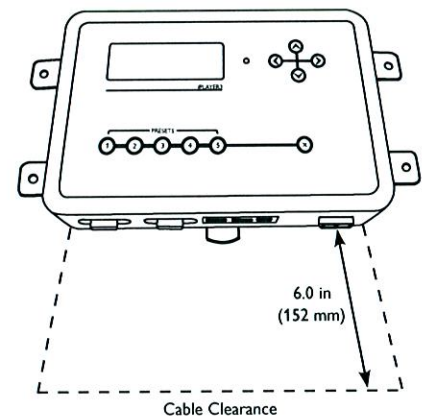

Copyright © 2015 Philips Solid-State Lighting Solutions, Inc. All rights reserved. Chromacore, Chromasic, CK, the CK logo, Color Kinetics, the Color Kinetics logo, ColorBlast, ColorBlaze, ColorBurst, ColorGraze, ColorPlay, ColorReach, iW Reach, eW Reach, DIMand, EssentialWhite, eW, iColor, iColor Cove, IntelliWhite, iW, iPlayer, Optibin, and Powercore are either registered trademarks or trademarks of Philips Solid-State Lighting Solutions, Inc. in the United States and / or other countries. All other brand or product names are trademarks or registered trademarks of their respective owners. Due to continuous improvements and innovations, specifications may change without notice. DAS-000020-01 R06 12 Aug 2015



Philips Color Kinetics
3 Burlington Woods Drive
Burlington, Massachusetts 01803 USA
Tel 888.385.5742
Tel 617.423.9999
Fax 617.423.9998
www.philipscolorkinetics.com

Color Wash



The Color Wash effect creates a smooth transition through a series of solid colors on all fixtures simultaneously.

Effect Type Name of effect type (not editable).

Start Start time of effect on the timeline (HH:MM:SS). Editing the Start property shifts the effect on the timeline and automatically updates the End property.

Duration Duration of effect on the timeline (HH:MM:SS). Editing the Duration property resizes the effect on the timeline and automatically updates the End property.

End End time of effect on the timeline (HH:MM:SS). Editing the End property resizes the effect on the timeline and automatically updates the Duration property.

Repeat The number of times to repeat the color wash within the effect duration. For example, if Repeat is set to 1 and Duration is set to 1:00, the effect transitions through the color sequence once in one minute. If Repeat is set to 3, the effect transitions through the color sequence three times in one minute.

Fade In Duration of fade in from the color selected in the Fade In Color property (HH:MM:SS).

Fade In Color Color to fade in from, using the duration set in the Fade In property. You change the color using the Palette Editor.

Fade Out Duration of fade out to the color selected in the Fade Out Color property (HH:MM:SS).

Fade Out Color Color to fade out to, using the duration set in the Fade Out property. You change the color using the Palette Editor.

Row Timeline row to which the effect is assigned (row 1 is the topmost row in the timeline). Changing the row changes the effect's priority in a stack, assigns the effect to a different group, or unassigns the effect.

Loop If false, the effect abruptly jumps from the last color in the sequence to the first color in the sequence at the end of each repeat and at the end of the effect. If true, smoothly fades from the last color in the sequence to the first color at the end of each repeat and at the end of the effect.

Palette The effect's sequence of display colors. You add, change, reorder, and delete colors using the Palette Editor.

Color Wash Example 1

Duration: 1:00 | Repeat: 1 | Loop: false



Effect transitions through a sequence of colors once, then jumps back to the first color when effect repeats

Color Wash Example 2

Duration: 1:00 | Repeat: 1 | Loop: true



Effect transitions through a sequence of colors once, then fades back to the first color when effect repeats

Color Wash Example 3

Duration: 1:00 | Repeat: 3 | Loop: false



The sequence of colors repeats three times within the total effect duration, jumping back to the first color each time

Color Wash Example 4

Duration: 1:00 | Repeat: 3 | Loop: true



The sequence of colors repeats three times within the total effect duration, fading back to the first color each time

Building Elevation

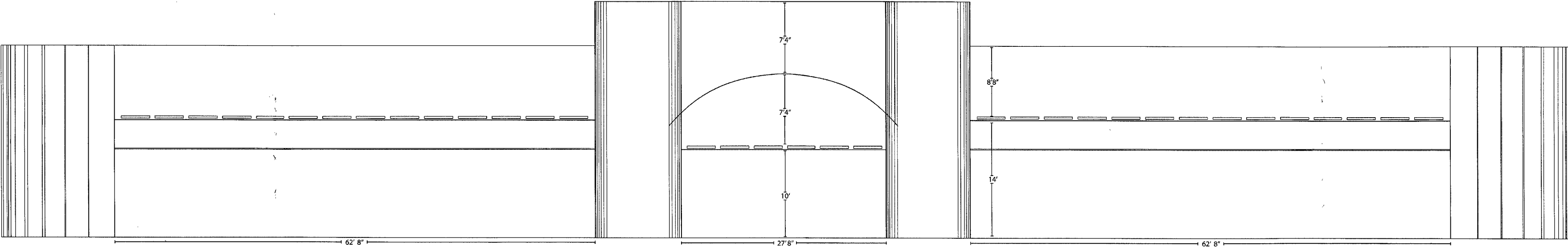

Roof Line Photometrics

Calculation Summary							
Label	CalcType	Units	Avg	Max	Min	Avg/Min	Max/Min
Center Roof Line	Illuminance	Fc	9.92	54	0	N.A.	N.A.
Left Side Roof Line	Illuminance	Fc	126.62	209	27	4.69	7.74
Right Side Roof Line	Illuminance	Fc	126.60	209	28	4.52	7.46

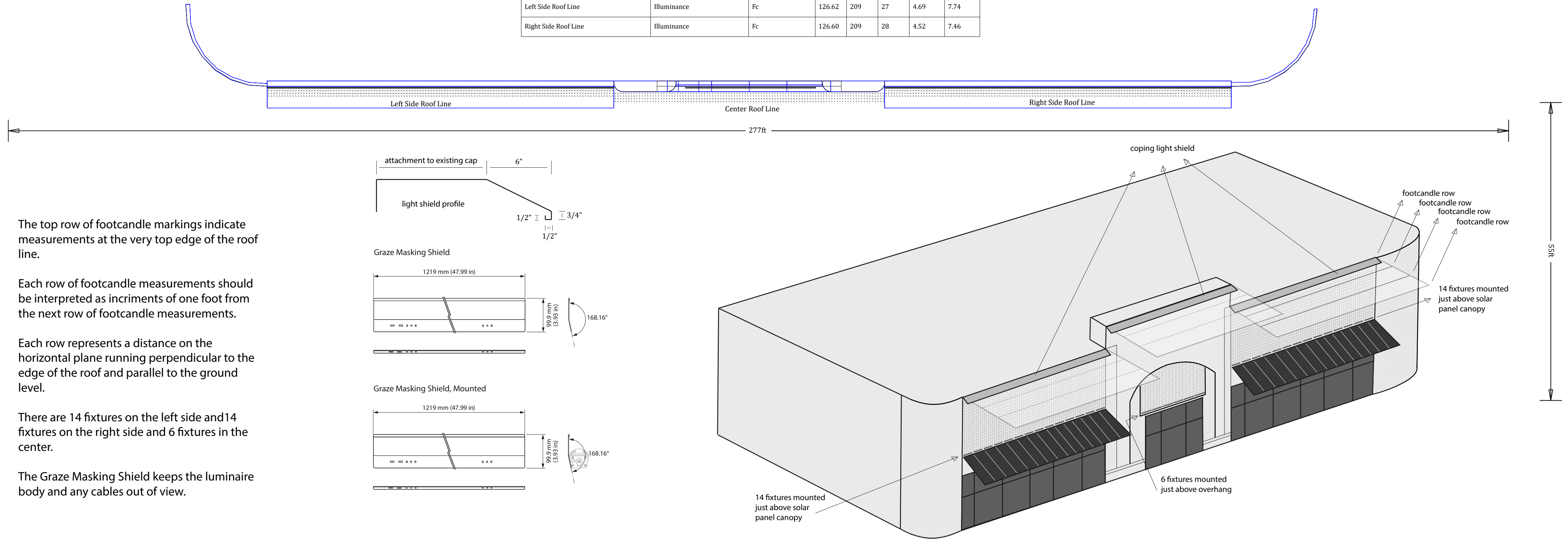

The top row of footcandle markings indicate measurements at the very top edge of the roof line.

Each row of footcandle measurements should be interpreted as increments of one foot from the next row of footcandle measurements.

Each row represents a distance on the horizontal plane running perpendicular to the edge of the roof and parallel to the ground level.

There are 14 fixtures on the left side and 14 fixtures on the right side and 6 fixtures in the center.

The Graze Masking Shield keeps the luminaire body and any cables out of view.

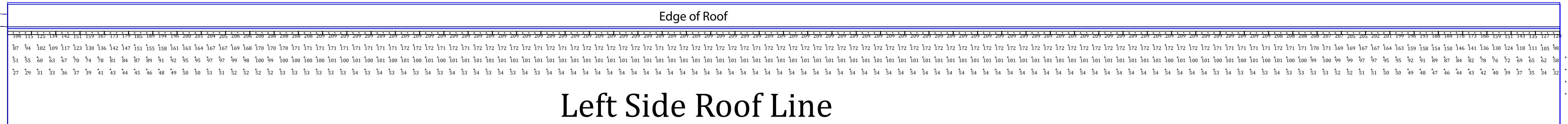

The Center Roof Line has different measurements than the Left Side Roof Line and the Right Side Roof Line. This is due to the fact that the fixtures in the center are mounted under an arched overhang. Therefore, above the arch, there is little to no footcandle measurements.

At 3 feet out from the edge of the building, the footcandle measurements are higher due to the bounce back of light from under the canopy.

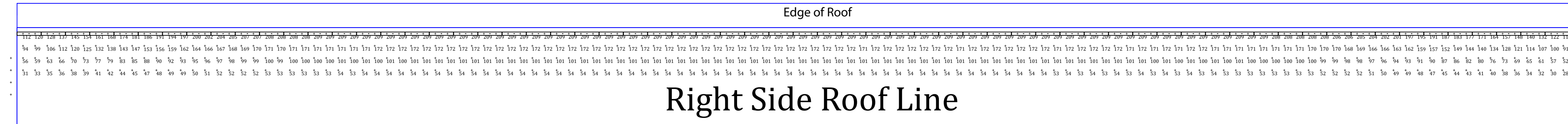
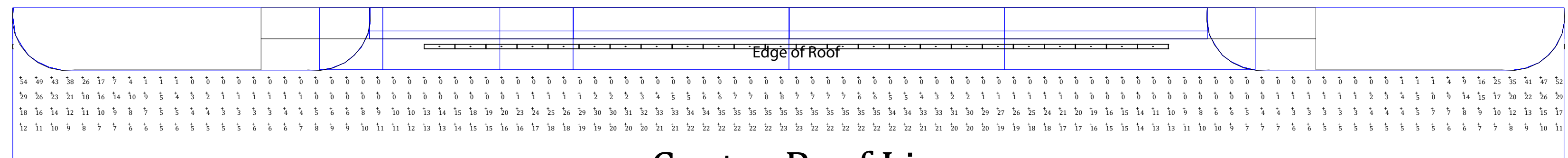

SHIELD BEAM SPREAD

Lateral View

