

## **Memorandum**

### **Department of Planning**



**To:** Planning and Public Works Committee

**From:** Annisa Kumerow, Planner **AK**

**Date:** May 21, 2020

**RE:** **TSG Chesterfield Airport Road, Lot A (Jaguar Land Rover):** A Site Development Section Plan, Landscape Plan, Mitigation Plan, Lighting Plan, Architectural Elevations and Architect's Statement of Design for an 8.728 acre tract of land zoned "PC" Planned Commercial District located north of Chesterfield Airport Road and east of Long Road. (Ward 4).

#### **Summary**

The request is for a 31,000 +/- square foot automobile dealership located north of Chesterfield Airport Road and east of Long Road. The site will house a retail showroom, sales office, and vehicle service facilities for a new Jaguar and Land Rover automobile dealership. The subject site is zoned "PC" Planned Commercial District and is governed under the terms and conditions of City of Chesterfield Ordinance Number 3082.

The project was reviewed by the Architectural Review Board on March 12, 2020. A motion was made to forward the Site Development Section Plan to the Planning Commission with a recommendation for approval by a vote of 4-0 with the following conditions:

- To further enhance the concept of a four sided building that has equal attractiveness of architectural elements on the front façade (show room) with the sides and rear (service area).
- Introduce a higher quality material, possibly the concrete tilt up panel vs. the corrugated metal as a primary material.

The project was reviewed by the Planning Commission on May 11, 2020. Planning Commission recommended approval of the request by a vote of 9 – 0, with the condition that six shade trees be relocated along the north property line. Power of Review was called in accordance with Section 31-02-20 of the Unified Development Code on May 14, 2020.

Attached to this report please find a copy of the Planning Commission Staff Report, Site Development Section Plan, Landscape Plan, Mitigation Plan, Lighting Plan, Architectural Elevations and Architect's Statement of Design.



- Attachments:
- Planning Commission Staff Report
  - Site Development Section Plan
  - Landscape Plan
  - Mitigation Plan
  - Lighting Plan
  - Architectural Elevations
  - Architect's Statement of Design







ROADWAY FIXTURES MOUNTED ON 25' POLE & 2.5' BASE  
ALL OTHER FIXTURES MOUNTED AT 20' INCLUDING BASE  
LIGHT LEVEL CALCULATED ON THE GROUND

Calculation Summary							
Label	CaleType	Units	Avg	Max	Min	Avg/Min	Max/Min
FRONT ROW DISPLAY @ 4'	Illuminance	Fe	6.35	7.8	4.9	1.30	1.59
JAGUAR LAND ROVER WAY	Illuminance	Fe	0.71	2.1	0.1	7.10	21.00
PARKING LOT	Illuminance	Fe	4.48	8.0	0.8	5.60	10.00
ROADWAY	Illuminance	Fe	1.17	4.0	0.0	N.A.	N.A.
ROADWAY_1	Illuminance	Fe	1.17	4.0	0.0	N.A.	N.A.
SPILL LIGHT	Illuminance	Fe	0.04	0.7	0.0	N.A.	N.A.

Luminaire Schedule							
Symbol	Qty	Label	Arrangement	LLF	Lum. Watts	Total Watts	Description
[Symbol]	3	EX	SINGLE	0.532	52	156	VMX-1-TS-32LC-3-4K-UNV
[Symbol]	11	F1	SINGLE	1.000	333	3663	GLEON-AF-06-LED-E1-SWQ
[Symbol]	1	F2	SINGLE	1.000	59	59	GLEON-AF-01-LED-E1-SL
[Symbol]	2	F4	SINGLE	1.000	113	226	GLEON-AF-02-LED-E1-SL3
[Symbol]	4	F5	SINGLE	1.000	225	900	GLEON-AF-04-LED-E1-SL4
[Symbol]	14	F6	SINGLE	1.000	113	1582	GLEON-AF-02-LED-E1-SL4
[Symbol]	1	F7	SINGLE	1.000	113	113	GLEON-AF-02-LED-E1-SLR
[Symbol]	3	R1	BACK-BACK	0.912	225	1350	GLEON-AF-04-LED-E1-SWQ
[Symbol]	2	BL	SINGLE	0.900	14.4	28.8	NT-3.5-LG4700-40-UNV

DESIGN IS BASED ON CURRENT INFORMATION PROVIDED AT THE TIME OF REQUEST. ANY CHANGES IN EXISTING HEIGHT OR LOCATION, LAMP WATTAGE, LAMP TYPE, AND EXISTING FIELD CONDITIONS, THAT AFFECT ANY OF THE PREVIOUSLY MENTIONED, WILL VOID CURRENT LAYOUT AND REQUIRE A CHANGE REQUEST AND RE-CALCULATION.

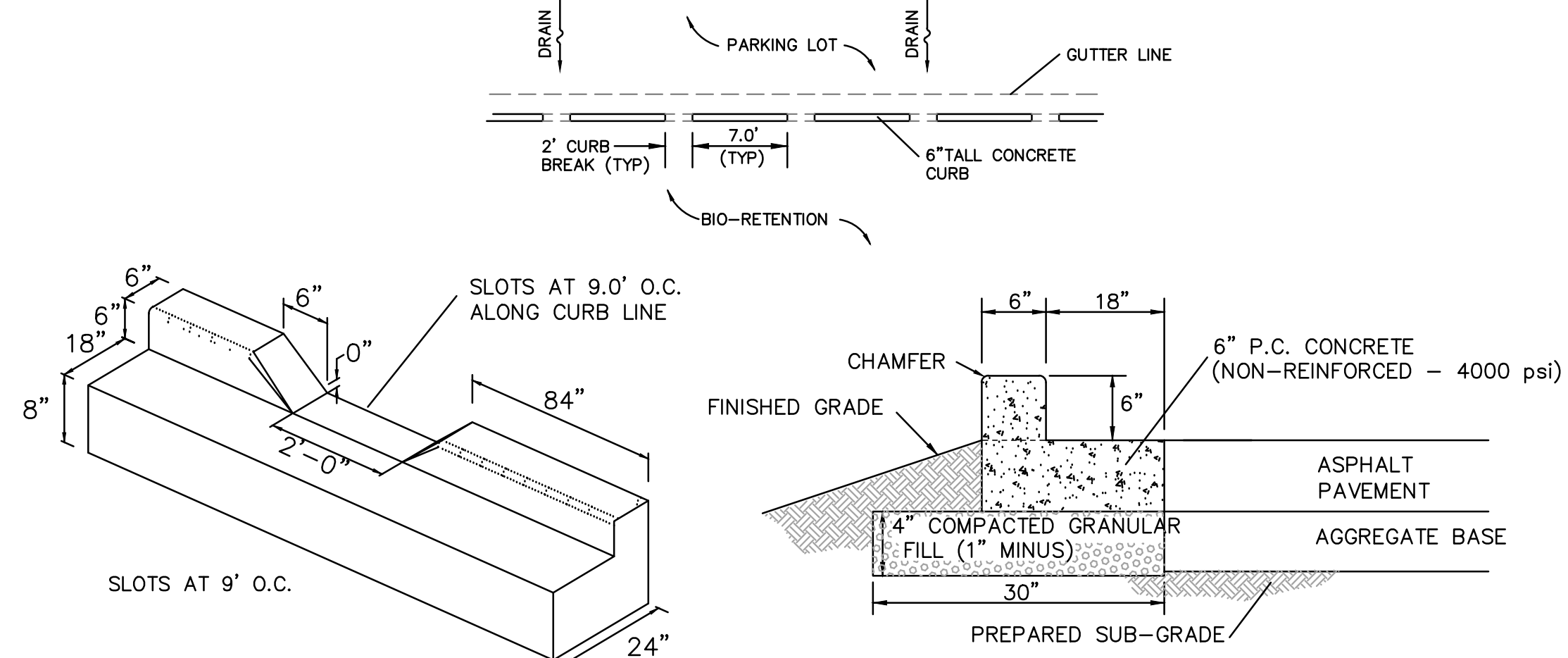
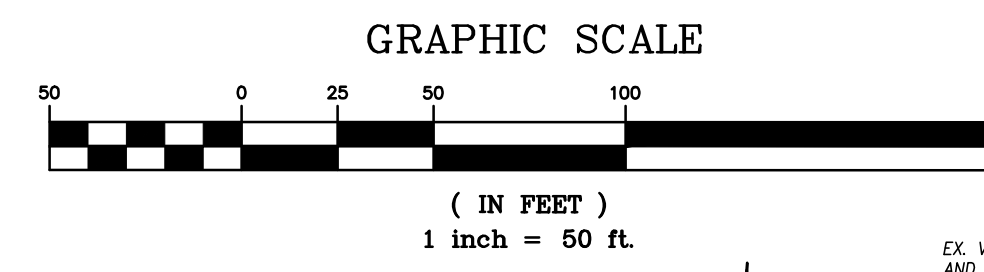

**SLOTTED CONC. CURB AND GUTTER DETAIL**  
(n.t.s.)  
FOR USE IN SHEET DRAIN AREAS OF CAR PARKING LOT & ENTRANCE DRIVES WITH FABRIC UNDER CURB & GUTTER

**SLOTTED CONC. CURB AND GUTTER DETAIL**  
(n.t.s.)  
FOR USE IN SHEET DRAIN AREAS OF CAR PARKING LOT & ENTRANCE DRIVES WITH FABRIC UNDER CURB & GUTTER

**STANDARD CONCRETE SLOTTED CURB DETAIL**  
(n.t.s.)

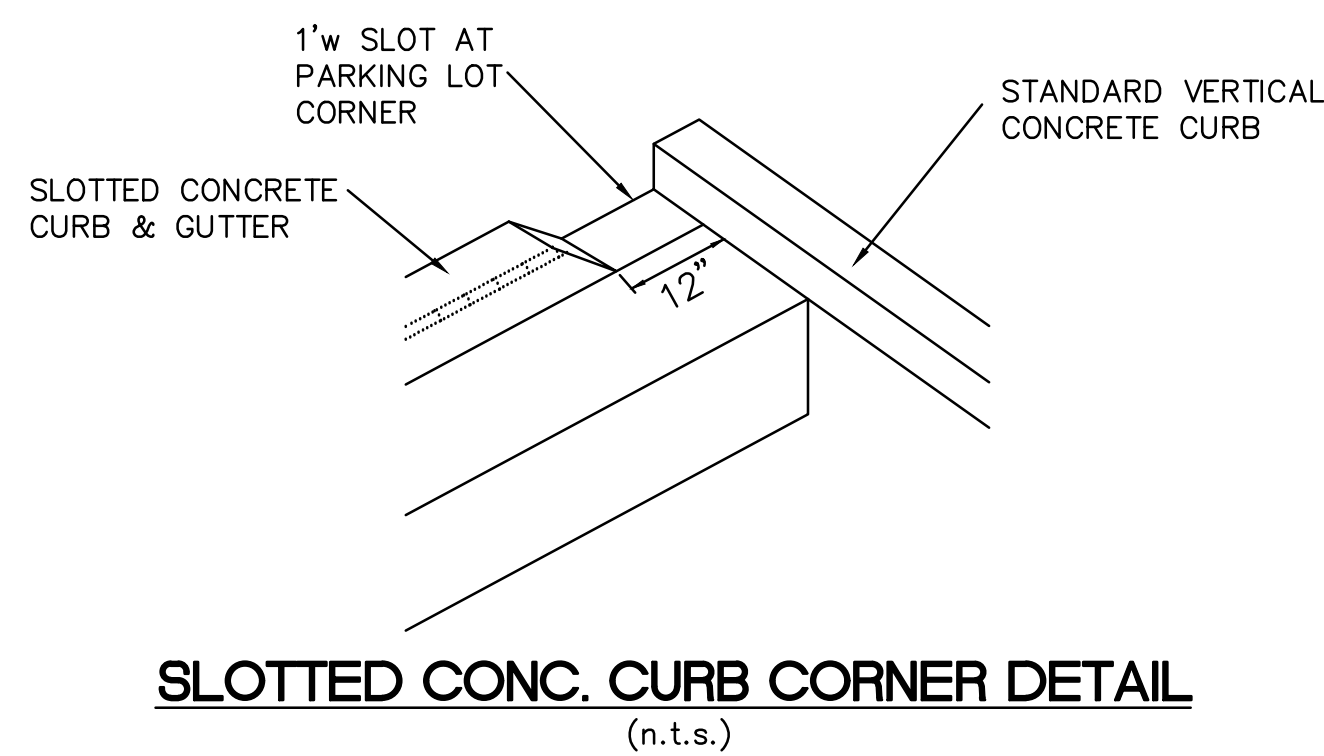

**SLOTTED CONC. CURB CORNER DETAIL**  
(n.t.s.)

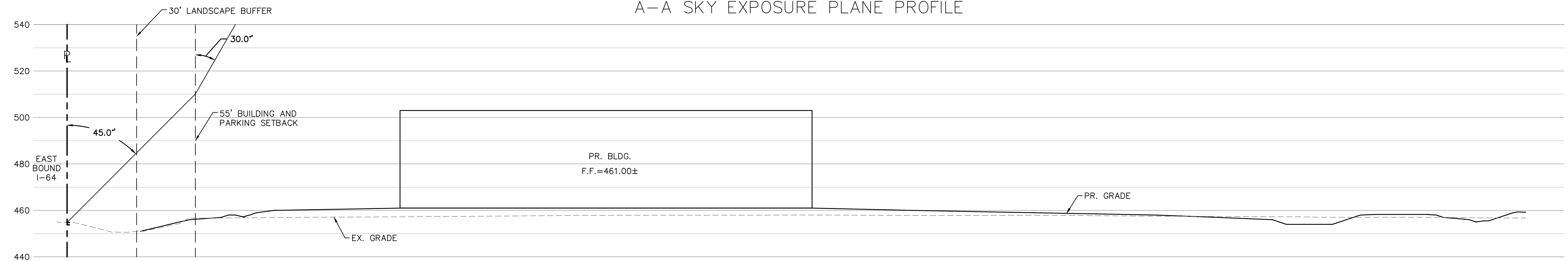

A-A SKY EXPOSURE PLANE PROFILE

**SKY EXPOSURE PLANE**  
SCALE: HORZ: 1" = 20'  
VERT: 1" = 20'

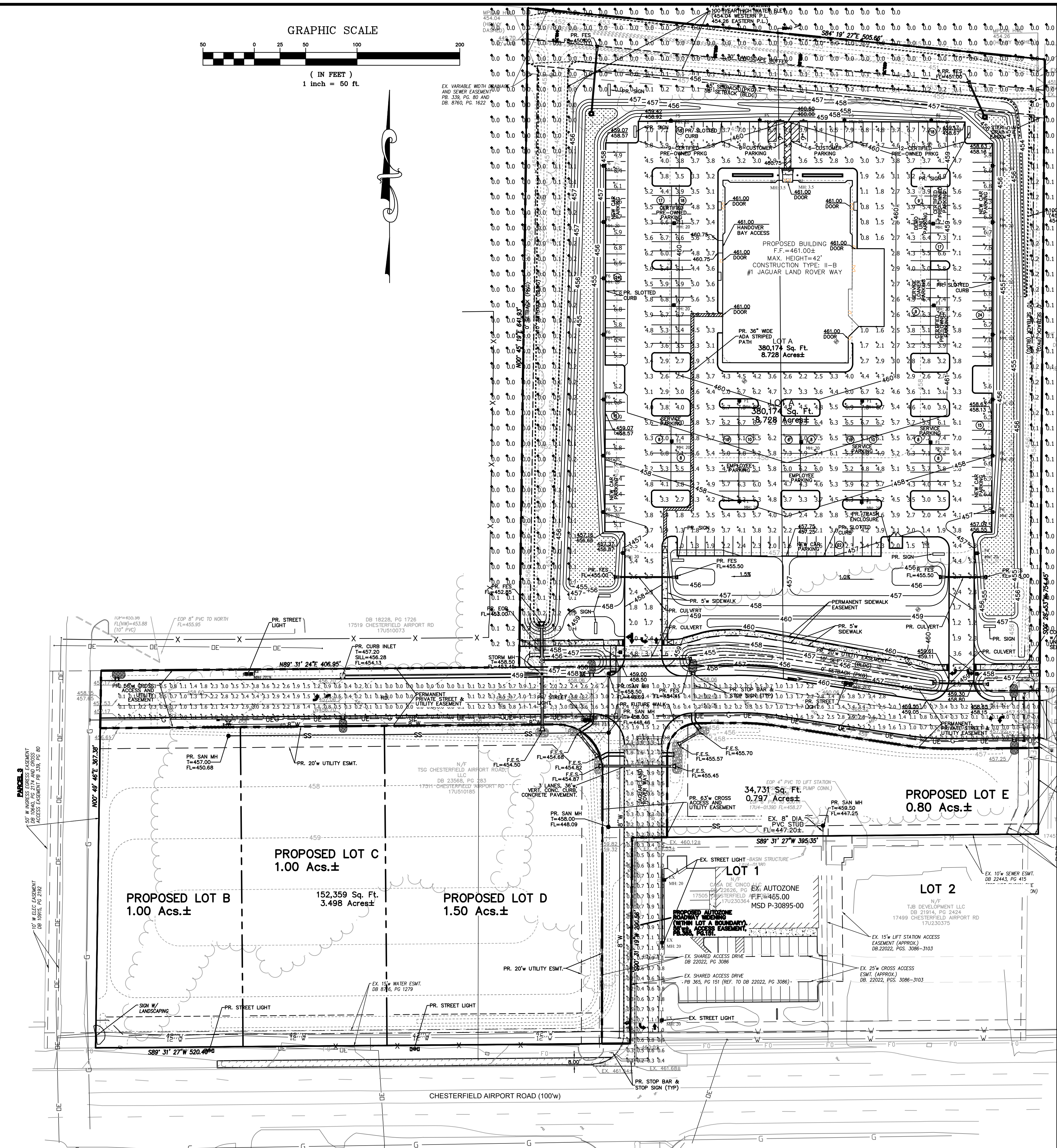

PREPARED BY: STOCK & ASSOCIATES Consulting Engineers, Inc.

**SITE DEVELOPMENT SECTION PLAN FOR:**  
**JAGUAR LAND ROVER CHESTERFIELD**  
CITY OF CHESTERFIELD, MO 63005

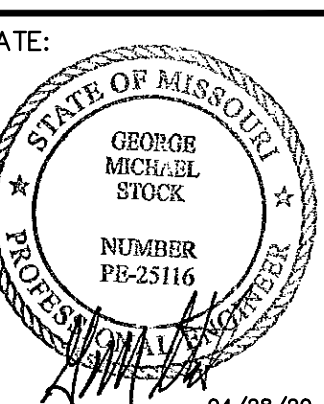

DATE: 04/28/20  
GEORGE M. STOCK E-25116  
CIVIL ENGINEER  
CERTIFICATE OF AUTHORITY NUMBER: 000996

REVISIONS:  
1 1/29/20 City Comments  
2 2/24/20 City Comments  
3 03/03/20 City Comments  
4 04/14/20 City Comments  
5 04/28/20 City Comments

RECEIVED  
City of Chesterfield  
Apr 28 2020  
Department of Public Services

DRAWN BY: K.S.C. CHECKED BY: G.M.S.  
DATE: 11/15/2019 JOB NO: 218-6407.4  
K.S.C. P.# 20MSD-00080 RISE MAP # 1705  
S.L.C. MAT # MAT SUP. #  
M.D.N.R. #  
SHEET TITLE: SITE DEVELOPMENT SECTION PLAN  
SHEET NO.: SDSP-2



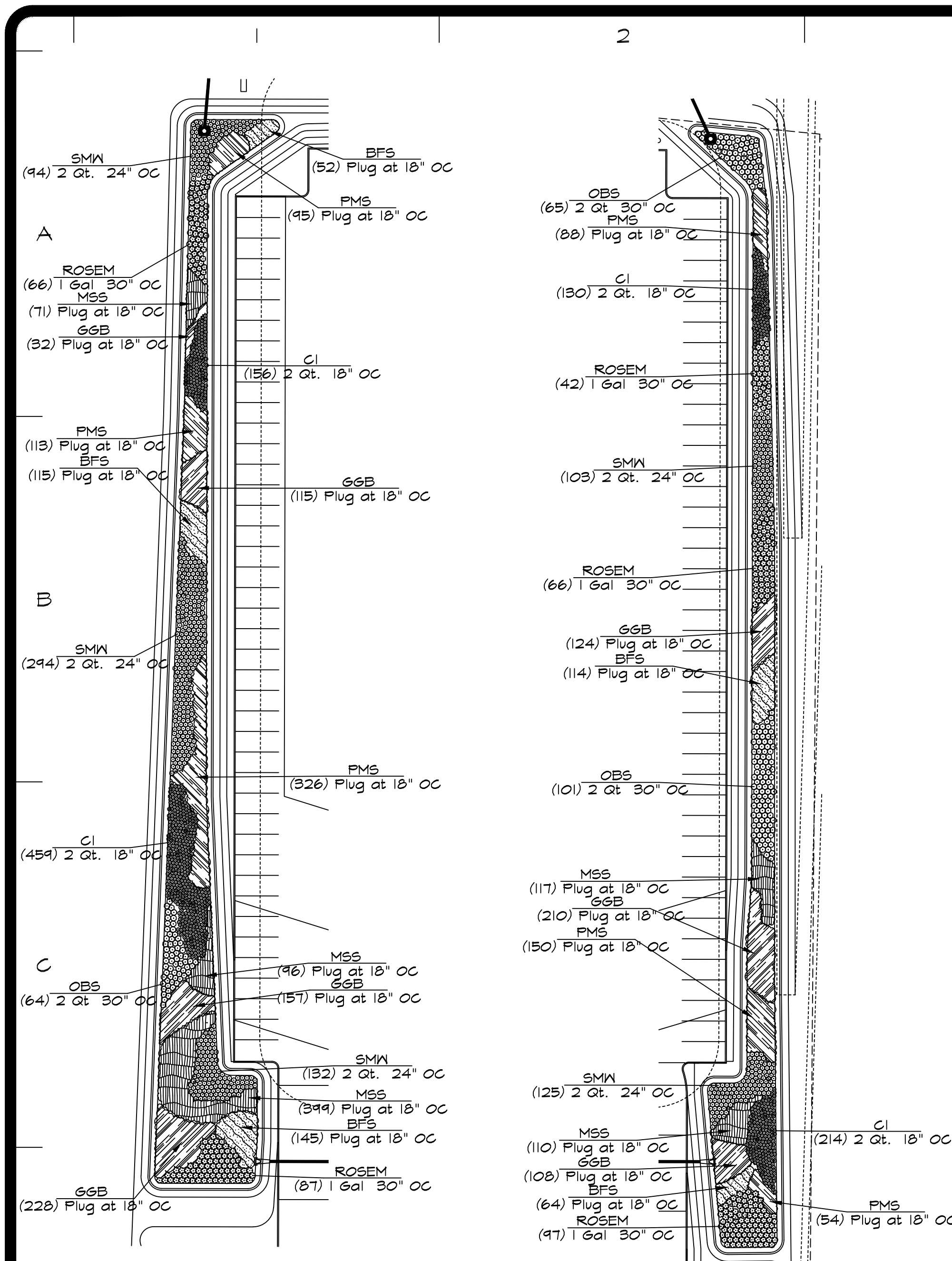

WEST BIO-RETENTION SCALE: 1"=40'-0"  
EAST BIO-RETENTION SCALE: 1"=40'-0"

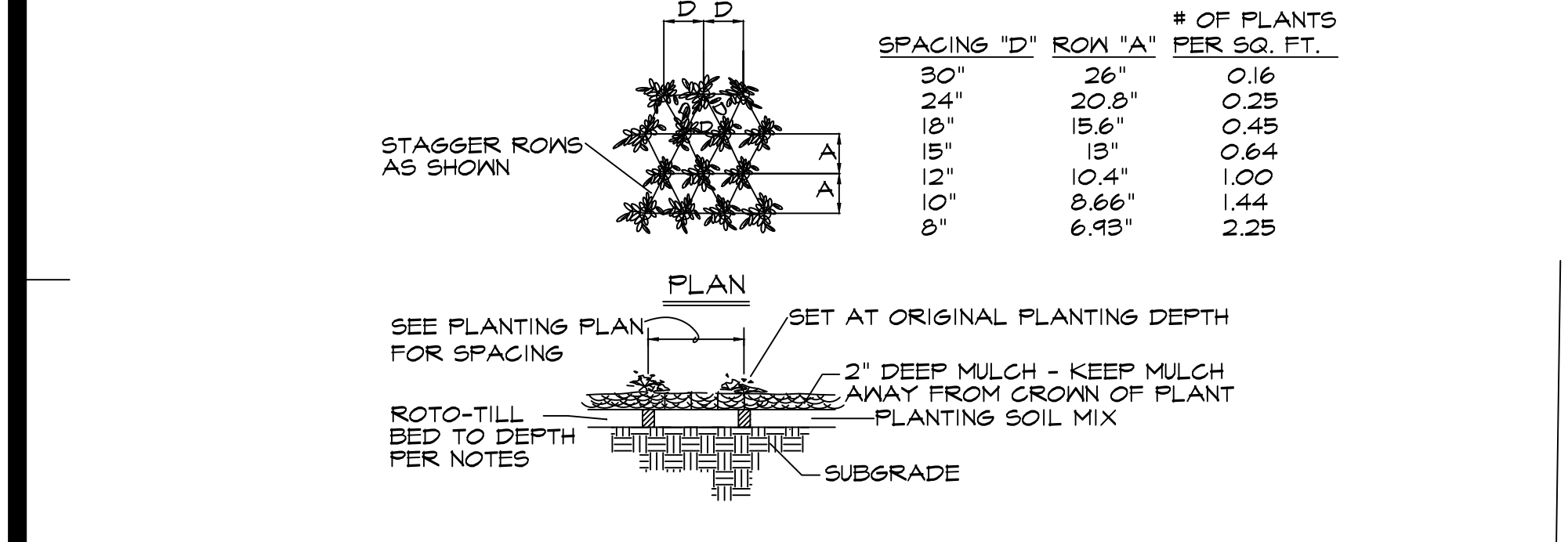

FORB/GRASS PLANTING DETAIL N.T.S.

PLANTING, WATER and MULCH REQUIREMENTS					
WATER AVAILABILITY	REQUIRED PERIOD	MINIMUM PLANT SIZE	WATER REQUIREMENT FIRST 3 WEEKS	WATER REQUIREMENT AFTER 3 WEEKS	MAXIMUM MULCH DEPTH
NO AVAILABILITY TO WATER AFTER	LATE FEB. ONLY	2.25"x3.75" LARGER	WATER EACH PLUS IMMEDIATELY	1" (60 MIN) EVERY 5 DAYS UNTIL PLANTS ESTABLISHED	1.5" FOR PLUGS 2.5" FOR QUARTS
MANUAL WATERING WITH STANDARD SPRINKLER	LATE FEB. THROUGH OCTOBER	4.25"x3.75" LARGER	1" (60 MIN) EVERY 5 DAYS	1" (60 MIN) EVERY 5 DAYS UNTIL PLANTS ESTABLISHED	1.5" FOR PLUGS 2.5" FOR QUARTS
AUTOMATIC IRRIGATION (WATER MORE FREQUENTLY THAN NORMAL DURING FIRST TWO MONTHS AFTER PLANTING)	LATE FEB. THROUGH OCTOBER	2.25"x3.75" LARGER	1" (60 MIN) EVERY 5 DAYS	1" (60 MIN) EVERY 5 DAYS UNTIL PLANTS ESTABLISHED	1.5" FOR PLUGS 2.5" FOR QUARTS

- BIO-RETENTION MAINTENANCE PROCEDURES:**
- ADD 2-4 INCHES OF MULCH (SEE CIVIL DWGS. FOR TYPE) TO THE ENTIRE NEWLY PLANTED RAIN GARDEN/BIO-RETENTION AREA. DO NOT COVER THE CROWNS OF THE PERENNIALS. REPLENISH THE MULCH AS NEEDED.
  - AVOID FINE CUT OR LIGHTER WEIGHT MULCHES AS THEY FLOAT IN WET CONDITIONS.
  - PRUNE ANY DEAD, DISEASED OR DAMAGED PLANTS AS SOON AS THE PROBLEM IS NOTICED. DEAD/HEAD PLANTS AS NEEDED AND DIVIDE PERENNIALS EVERY 3-4 YEARS AS NEEDED. LEAVE STEMS AND SEED HEADS STANDING IN FALL/WINTER TO ADD VISUAL INTEREST AND TO PROVIDE FOOD AND COVER FOR BIRDS.
  - PRUNE THE FOLIAGE OF PERENNIALS WHEN THEY DIE BACK FOR THE WINTER AND ORNAMENTAL GRASSES BEFORE NEW GROWTH BEGINS IN THE SPRING.
  - HAND WEED BIWEEKLY UNTIL PLANTS ARE ESTABLISHED. THEREAFTER, REMOVE OR SPOT KEEPS AS NECESSARY.
  - WATER THE GARDEN DURING ITS ESTABLISHMENT AND EXTENDED DRY PERIODS. ONE INCH OF WATER PER WEEK IS RECOMMENDED.
  - DO NOT USE LAWN FERTILIZERS NEAR GARDEN AREA AS THIS WILL STIMULATE WEED GROWTH.
  - EACH SPRING, MOW AND REMOVE DEAD VEGETATION. USE BURNING ONLY UNDER SUPERVISION OF LOCAL FIRE DEPARTMENT (NATIVE PLANTS THRIVE UNDER FIRE MANAGEMENT).

- NOTE:**
- ALL NATIVE GRASS PLUGS ARE TO BE A MINIMUM 4.5" DEEP X 2" DIAMETER.
  - CONTRACTOR TO PROVIDE SIGNED AND SEALED SHOP DRAWINGS TO BE APPROVED BY THE PROJECT ENGINEER AND MSD. CONTACT MSD AT 314/395-2072.
  - DURING CONSTRUCTION THE BIO-RETENTION AREAS MAY TRAP SEDIMENT. FINAL CONSTRUCTION AND PLANTING OF THE BIO-RETENTION AREAS SHALL BE COMPLETED AFTER SILT AND DEBRIS IS REMOVED.
  - HEAVY EQUIPMENT SHALL BE KEPT OFF OF THE SOIL MIX DURING CONSTRUCTION OPERATIONS TO AVOID COMPACTING. FOOT TRAFFIC AND PRE-SOAKING TO AID NATURAL COMPACTION IS ALLOWABLE.
  - SOIL PH SHALL FALL IN THE RANGE OF 5.5 AND 7.
  - SEE CIVIL DRAWINGS FOR CROSS-SECTIONAL DETAILS OF MULCH AND SOIL MANDP.

**PLUG PLANTING NOTES:**

- All plugs to be 4-1/2" deep X 2" diameter minimum.
- Plugs are to be planted in a hole dug with a trowel, spade or planting bar such that the hole is of a minimum diameter and depth to accommodate the plug and its roots, without damage.
- Plugs shall be spaced in a triangulated layout approximately 24" on center. Plugs shall be planted through erosion control blankets where appropriate.
- Obtain plugs from a reputable nursery.
- Water plugs upon completion of planting so that soil is moist but not saturated.
- If planting is delayed more than six hours after delivery, store plugs in the shade, protect from weather and mechanical damage and keep them moist and cool. All plugs shall be planted within 24 hours after delivery.

**PLEASE NOTE:**

- ALL LANDSCAPE AREAS & ISLANDS SHALL BE PROVIDED WITH A MECHANICAL IN-GRADE IRRIGATION SYSTEM (BY OTHERS), COORDINATE LANDSCAPING WITH IRRIGATION CONTRACTOR.
- ALL PLANTING BEDS TO BE EDGED W/ SPADE-CUT EDGE UNLESS OTHERWISE NOTED.
- ADJUST TREE LOCATIONS FOR LIGHT STANDARDS AND UNDERGROUND UTILITIES.
- NO TREES OR OTHER OBSTRUCTIONS SHALL BE LOCATED WITHIN 6 FEET OF FIRE HYDRANTS.
- ALL SHRUBS/PERENNIALS WITHIN 35' SIGHT TRIANGLE ZONES TO BE MAINTAINED AT A MAXIMUM HEIGHT OF TWENTY FOUR INCHES (2 FEET); ALL TREES TO BE MAINTAINED WITH A CLEAR HEIGHT FROM GRADE OF TEN (10) FEET.

**STREET TREES:** 1 per 50 LF FRONTAGE

- 508.24 LF FRONTAGE @ ARNAGE ROAD REQUIRING 11 TREES @ 2.5" CALIFER. ELEVEN (11) TREES ARE PROPOSED.

**TOTAL TREES:** 248 TOTAL --- 53 FAST GROWTH (21%) and 195 SLOW-MEDIUM GROWTH (79%)

- 114 DECIDUOUS SHADE TREES (46%)
- 44 EVERGREEN TREES (20%)
- 87 ORNAMENTAL TREES (34%)

**PLEASE NOTE:**

- STREET TREES SHALL NOT BE PLANTED CLOSER THAN THREE (3) FEET FROM ANY CURB.
- STREET TREES SHALL NOT BE PLACED WITHIN 25 FEET OF STREETLIGHTS, STREET SIGNS AND INTERSECTIONS.
- NO TREES SHALL BE PLANTED WITHIN TEN (10) FEET OF STREET INLETS OR MANHOLES.

**SITE COVERAGE CALCULATIONS:**

TOTAL SITE	380,174 S.F.	100%	(8.728 Acres)
BUILDING	24,670 S.F.	7.81%	(0.57 Acres)
OPEN SPACE	166,576 S.F.	43.82%	(3.82 Acres)
PAVEMENT	124,380 S.F.	39.42%	(2.86 Acres)

**IRRIGATION GUIDELINE SPECS:**

- GENERAL:**
- System shall be designed for 30 gpm @ 80 PSI. Contractor to field verify actual conditions.
  - Excess top, backflow and controller location to be coordinated with owner or owner's representative.
  - All control wiring to be 14 ga. Minimum 3 extra strands to be installed in each direction from the controller to the end of the mainline.
  - All piping to be sleeved in SCH40 PVC when passing under landscape. PVC Sleeve to be a minimum of twice the size of pipe(s) running through.
  - Underground facilities, structures and utilities must be considered approximate only. There may be others not presently known or shown. It shall be the irrigation contractor's responsibility to determine or verify the existence of and exact location of the above (Call 1-800-DIG-RITE).
  - It shall be the irrigation contractor's responsibility to:
    - Verify all existing and proposed features shown on the drawings prior to commencement of work.
    - Report all discrepancies found with regard to existing conditions or proposed design to the landscape architect immediately for a decision.

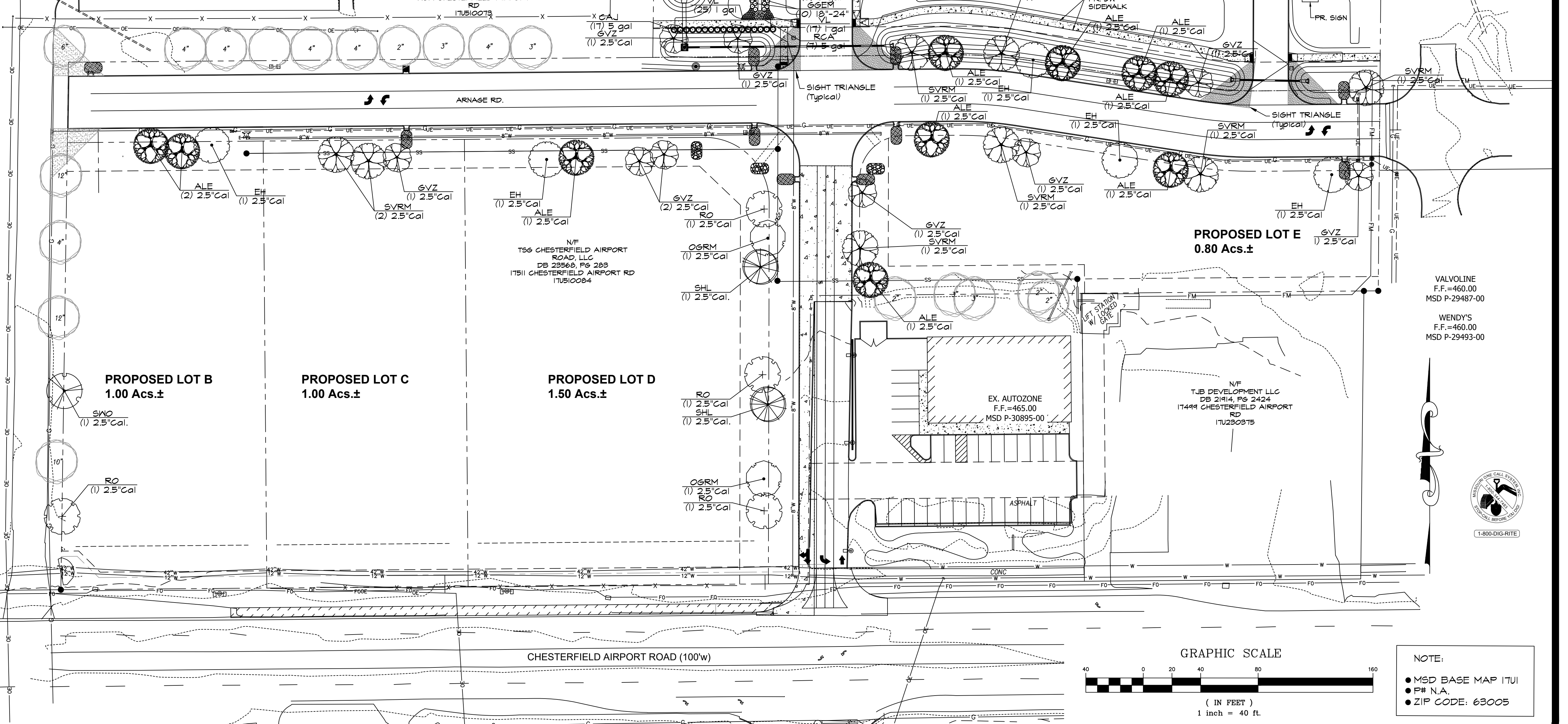

RECEIVED  
City of Chesterfield  
Apr 28 2020  
Department of Public Services

REVISIONS	BY
12/9/19	RMM
1/28/2020	RMM
2/10/2020	RMM
2/18/2020	RMM
2/21/2020	RMM
2/24/2020	RMM
3/19/2020	RMM

**Landscap**  
TECHNOLOGIES

67 Jacobs Creek Drive  
St. Louis, MO 63105  
TEL: 314-432-1200  
FAX: 314-432-1201  
www.landscaptechnologies.com

REGISTERED PROFESSIONAL LANDSCAPE ARCHITECT  
STATE OF MISSOURI  
RANDALL W. HARDSHIP  
NUMBER 13317  
DATE: 5/19/2020

MASTER PLANTING PLAN FOR THE PROPOSED  
**Jaguar Land Rover Chesterfield**  
1 JAGUAR LAND ROVER WAY. CHESTERFIELD, MO 63005

DRAWN	R. HARDSHIP
CHECKED	RMM/ML
DATE	12/16/19
SCALE	1"=40'-0"
JOB NO.	2019-176
SHEET	L-1

OF THREE SHEETS

**NOTE:**

- MSD BASE MAP 1701
- PR N.A.
- ZIP CODE: 63005

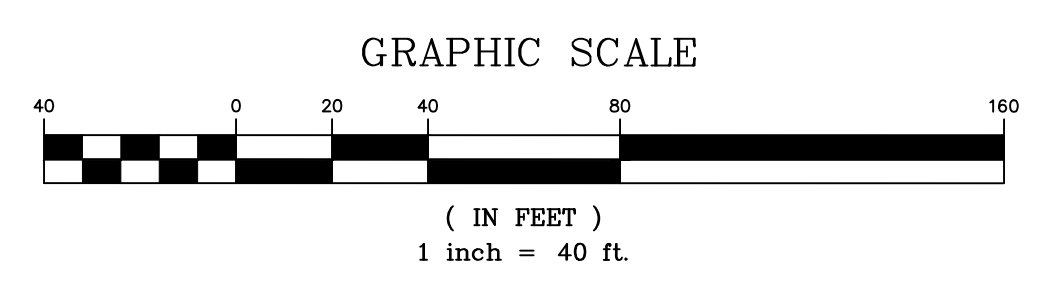



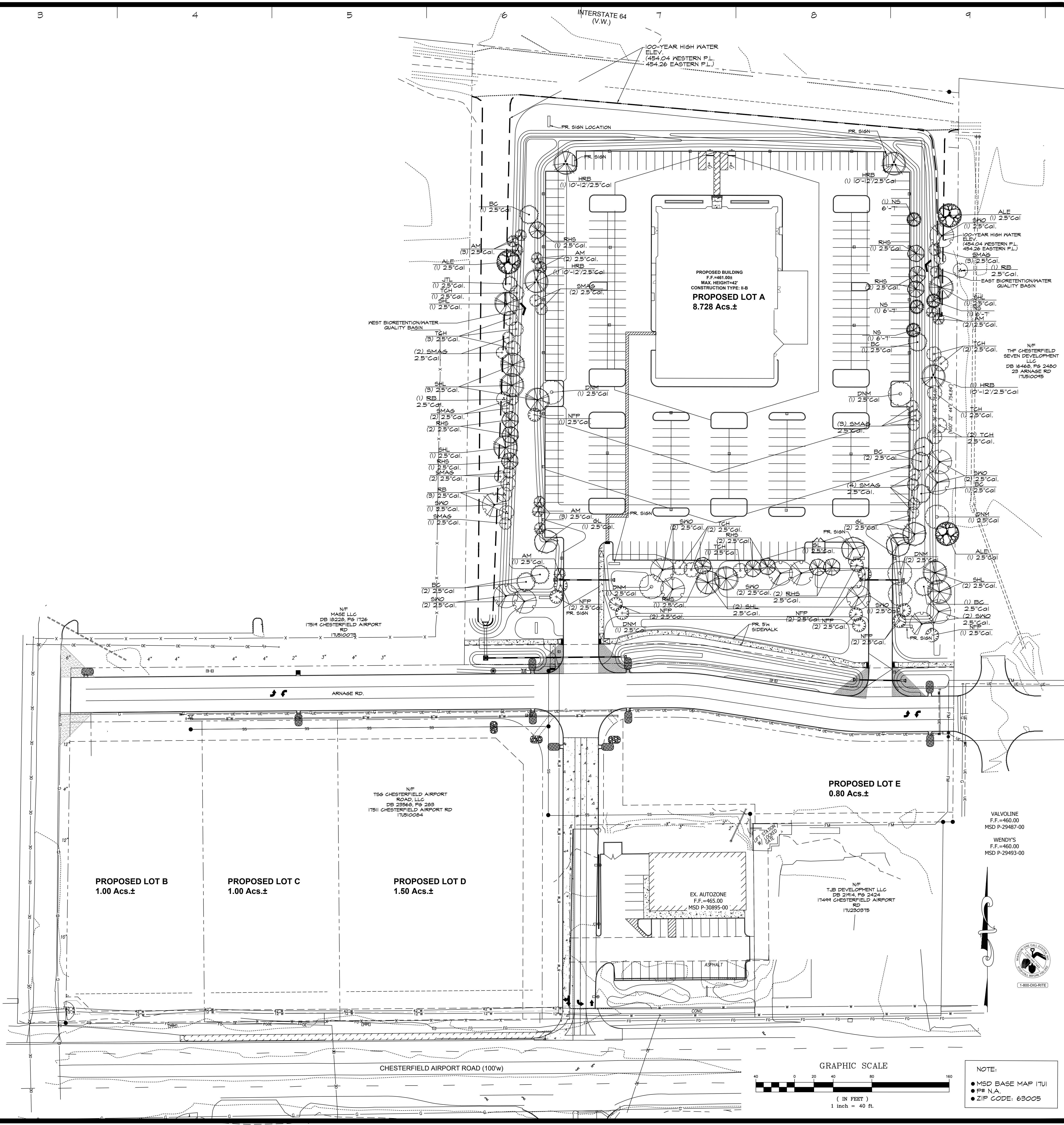

INTERSTATE 64 (V.V.)  
100-YEAR HIGH WATER ELEV. (454.04 WESTERN P.L., 454.26 EASTERN P.L.)

PROPOSED BUILDING  
F.F.=461.00  
MAX HEIGHT=42'  
CONSTRUCTION TYPE: II-B  
**PROPOSED LOT A**  
8.728 Acs.±

**PROPOSED LOT E**  
0.80 Acs.±

**PROPOSED LOT B**  
1.00 Acs.±

**PROPOSED LOT C**  
1.00 Acs.±

**PROPOSED LOT D**  
1.50 Acs.±

N/F  
T56 CHESTERFIELD AIRPORT ROAD LLC  
DB 20560, PG. 205  
17514 CHESTERFIELD AIRPORT RD  
17U500275

EX. AUTOZONE  
F.F.=465.00  
MSD P-30895-00

N/F  
TUB DEVELOPMENT LLC  
DB 21414, PG. 214  
17444 CHESTERFIELD AIRPORT RD  
17U280375

VALVOLINE  
F.F.=460.00  
MSD P-29487-00

WENDY'S  
F.F.=460.00  
MSD P-29493-00

CHESTERFIELD AIRPORT ROAD (100'w)

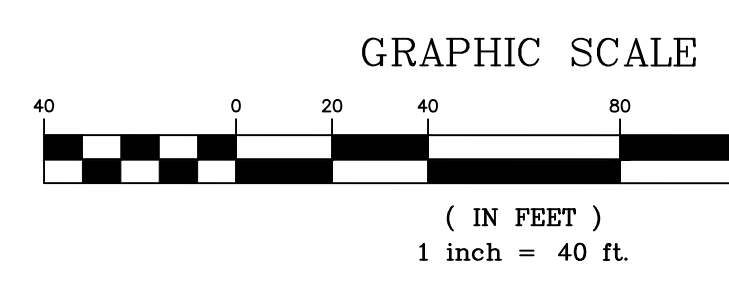

NOTE:  
● MSD BASE MAP 17U1  
● PR N.A.  
● ZIP CODE: 63005

REVISIONS	BY
12/9/19	RMM
1/28/2020	RMM
2/10/2020	RMM
2/18/2020	RMM
2/21/2020	RMM
2/24/2020	RMM
3/19/2020	RMM

**Landscapse TECHNOLOGIES**  
67 Jacota Creek Drive  
(636) 493-1250  
100 Landscape Architectural Corporation, #202002020

*Randall W. Mardis*  
RANDALL W. MARDIS  
LANDSCAPE ARCHITECT #000019  
MISSOURI LANDSCAPE ARCHITECT  
DATE: 5/19/2020

MITIGATION PLANTING PLAN FOR THE PROPOSED  
**Jaguar Land Rover Chesterfield**  
1 JAGUAR LAND ROVER WAY. CHESTERFIELD, MO 63005

DRAWN  
R. MARDIS  
CHECKED  
RMM/VEL  
DATE  
12/16/19  
SCALE  
1"=40'-0"  
JOB No.  
2019-176  
SHEET

**L-2**  
OF THREE SHEETS



# LANDSCAPE GUIDELINE SPECS:

## GENERAL:

- 1) All natural vegetation shall be maintained where it does not interfere with construction or the permanent plan of operation. Every effort possible shall be made to protect structures or vegetation from damage due to equipment usage. Contractor shall at all times protect all materials and work against injury to public.
  - 2) The landscape contractor shall be responsible for any coordination and sequencing with other site related work being performed by other contractors. Refer to additional drawings for further coordination of work to be done.
  - 3) Underground facilities, structures and utilities must be considered approximate only. There may be others not presently known or shown. It shall be the landscape contractor's responsibility to determine or verify the existence of any exact location of the above (Call utility location services in municipality).
  - 4) Plant material are to be planted in the same relationship to grade as was grown in nursery conditions. All planting beds shall be cultivated to 6" depth minimum and graded smooth immediately before planting of plants. Plant groundcover to within 12" of trunk of trees or shrubs planted within the area.
  - 5) It shall be the landscape contractor's responsibility to:
    - A) Verify all existing and proposed features shown on the drawings prior to commencement of work.
    - B) Report all discrepancies found with regard to existing conditions or proposed design to the landscape architect immediately for a decision.
    - C) Stake the locations of all proposed plant material and obtain the approval of the owner's representative or landscape architect ten (10) days prior to installation.
  - 6) Items shown on this drawing take precedence over the material list. It shall be the landscape contractor's responsibility to verify all quantities and conditions prior to implementation of this plan. No substitutions of types or size of plant materials will be accepted without written approval from the landscape architect.
  - 7) Provide single-stem trees unless otherwise noted in plant schedule.
  - 8) All plant material shall comply with the recommendations and requirements of ANSI Z60.1 "American Standards for Nursery Stock".
  - 9) It shall be the contractor's responsibility to provide for inspection of the plant material by the Landscape Architect (or Owners' Representative) prior to acceptance. Inspections may take place before, during or after installation. Plants not conforming exactly to the plant list will not be accepted and shall be replaced at the landscape contractor's expense.
  - 10) All bids are to have unit prices listed. The Owner has the option to delete any portion of the contract prior to signing the contract or beginning work. This will be a unit price contract. Quotes shall be valid for 12 months.
  - 11) Should auger equipment be utilized in excavating any plant pits, vertical sides of plant pits shall be thoroughly scarified to avoid creation of "polished side walls" prior to plant material installation.
  - 12) All excess topsoil, rocks, debris and/or tainted soils shall be removed by the general contractor prior to point project is turned over to the landscape contractor to commence landscape installation.
  - 13) Keep all plant material (except turf) a minimum of 36" clear of fire hydrants.
  - 14) Landscape contractor shall kill & remove all existing weeds within the project site.
  - 15) All tags, nursery stakes, labels, etc. shall be removed by the landscape contractor at completion of all landscape installation.
  - 16) Landscape contractor shall be in compliance with all federal, state and local laws / regulations relating to insect infestation and/or plant diseases.
  - 17) All substitutions of plant material shall be submitted to landscape architect for approval.
- PRUNING:**
- 1) Lightly prune trees at time of planting. Prune only the crossover limbs, damaged leader and/or any broken branches. Some interior trigs and lateral branches may be pruned. However, do not remove the terminal buds of branches that extend to the edge of the crown.
  - 2) All pruning shall comply with ANSI A300 standards.
- INSURANCE:**
- 1) The landscape contractor shall submit certificates of insurance for workman's compensation and general liability.
- MULCH:**
- 1) All mulch to be shredded oak bark mulch at 3" depth (after compaction) unless otherwise noted. Mulch shall be clean and free of all foreign materials, including weeds, mold, deleterious materials, etc.
  - 2) No plastic sheeting or filter fabric shall be placed beneath shredded bark mulch beds. Mireaf fabric shall be used beneath all gravel mulch beds. Lap fabric 6" over adjacent coverages.
  - 3) Edge all beds with spade-cut edge unless otherwise noted.
- MAINTENANCE:**
- 1) Landscape Contractor shall provide a separate proposal to maintain all plants, shrubs, groundcover, perennials and annuals for a period of 12 months after acceptance.
  - 2) Contractor shall ensure that only competent and trained personnel shall provide such services and that such services be provided in a timely manner.
  - 3) Watering of seeded or sodded lawns shall begin immediately and shall continue to be provided continuously for the following 12 hours. Regardless, the landscape contractor shall be responsible for all landscape maintenance until project turnover.
- SIGHT TRIANGLES:**
- 1) No landscape material or other obstructions shall be placed or be maintained within the sight triangle area so as not to impede the vision between a height of thirty inches (30") and ten feet (10') above the adjacent street or paving surfaces.
  - 2) Sight triangles at the intersection of a public street and a private access way (except for single family residences) shall also be formed by measuring from the point of the street frontage curbs and the entrance curb lines a distance of 35' and connecting the points so established to form the sight triangle area.
- TOPSOIL:**
- 1) Topsoil mix for all proposed landscape plantings shall be five (5) parts well-drained screened organic topsoil to one (1) part Canadian sphagnum peat moss as per planting details. Ratio= 5:1 topsoil mix to a depth of 6" minimum and grade smooth.
  - 2) Provide a soil analysis, as requested made by an independent soil-testing agency outlining the % of organic matter, inorganic matter, deleterious material, pH and mineral content.
  - 3) Any foreign topsoil used shall be free of roots, stumps, weeds, brush, stones (larger than 1"), litter or any other extraneous or toxic material. Landscape contractor shall be fully responsible for correcting all negative soil issues prior to plant installation. Killing and removal of all weeds shall be the responsibility of the landscape contractor as part of the site preparation.
  - 4) Landscape contractor to apply pre-emergent herbicide to all planting beds upon completion of planting operations and before application of shredded bark mulch.
  - 5) Install siltation controls prior to commencement of any grading operations. Inspect and maintain all siltation fences on a weekly basis until vegetation is established.
- WARRANTY:**
- 1) All plant material (excluding ground cover, perennials and annuals) are to be warranted for a period of 12 months after complete installation of all landscape material at 100% of the installed price.
  - 2) Any plant material found to be defective shall be removed and replaced within 30 days of notification or in growth season determined to be best for that plant.
  - 3) Only one replacement per tree or shrub shall be required at the end of the warranty period, unless loss is due to failure to comply with the warranty.
  - 4) Lawn establishment period will be in effect once the lawn has been mowed three times. Plant establishment period shall commence on the date of acceptance and 100% completion.
  - 5) A written guarantee shall be provided to the owner per conditions outlined in #1 above.

## PLANT SCHEDULE - BASE PLANTING

TREES	QTY	COMMON / BOTANICAL NAME	SIZE	D	Slow	Moderate	Fast	< 6"	6" - 18"	18" - 36"	> 3'	< 18"	3 - 6'	6 - 10'	10 - 15'	> 15'	< 15'	15 - 25'	25 - 40'	40 - 65'	> 65'	
ARM	4	Armstrong Red Maple / Acer rubrum 'Armstrong'	2.5'Gal	D																		
ALE	11	Athena Lacebark Elm / Ulmus parvifolia 'Emer 1'	2.5'Gal	D																		
EH	5	European Hornbeam / Carpinus betulus	2.5'Gal	D																		
GVZ	4	Green Vase Zelkova / Zelkova serrata 'Green Vase'	2.5'Gal	D																		
GL	6	Greenspire Littleleaf Linden / Tilia cordata 'Greenspire'	2.5'Gal	D																		
RC	4	Red Oak / Quercus rubra	2.5'Gal	D																		
BVRM	3	Sun Valley Red Maple / Acer rubrum 'Sun Valley'	2.5'Gal	D																		
SNO	1	Swamp White Oak / Quercus bicolor	2.5'Gal	D																		
AM	3	Flame Amur Maple / Acer ginnala 'Flame'	2.5'Gal	D																		
OGRM	2	October Glory Maple / Acer rubrum 'October Glory'	2.5'Gal	D																		
SKL	2	'Skyline' Locust / Gleditsia triacanthos 'Skyline'	2.5'Gal	D																		

EVERGREEN TREES	QTY	COMMON / BOTANICAL NAME	SIZE	E	Slow	Moderate	Fast	< 6"	6" - 18"	18" - 36"	> 3'	< 18"	3 - 6'	6 - 10'	10 - 15'	> 15'	< 15'	15 - 25'	25 - 40'	40 - 65'	> 65'	
GBS	16	Colorado Blue Spruce / Picea pungens 'Glauca'	6"-T	E																		
EMARB	4	Emerald Arborvitae / Thuja occidentalis 'Emerald'	6"-T	E																		
NS	20	Norway Spruce / Picea abies	6"-T	E																		

FLOWERING TREES	QTY	COMMON / BOTANICAL NAME	SIZE	O	Slow	Moderate	Fast	< 6"	6" - 18"	18" - 36"	> 3'	< 18"	3 - 6'	6 - 10'	10 - 15'	> 15'	< 15'	15 - 25'	25 - 40'	40 - 65'	> 65'	
JTL	22	Ivory Silk Japanese Tree Lilac / Syringa reticulata 'Ivory Silk'	2.5'Gal	O																		
RHS	4	Robin Hill Serviceberry / Amelanchier X grandiflora 'Robin Hill'	2.5'Gal	O																		

SHRUBS	QTY	COMMON / BOTANICAL NAME	SIZE	S	Slow	Moderate	Fast	< 6"	6" - 18"	18" - 36"	> 3'	< 18"	3 - 6'	6 - 10'	10 - 15'	> 15'	< 15'	15 - 25'	25 - 40'	40 - 65'	> 65'	
BLIN	10	Buffalo Juniper / Juniperus sabina 'Buffalo'	5 gal	S																		
CAJ	35	Compact Andorra Juniper / Juniperus horizontalis 'Flumosa Compacta'	5 gal	S																		
GN	31	Coppertina Ninebark / Physocarpus opulifolius 'Coppertina'	5 gal	S																		
GGEM	40	Green Gem Boxwood / Buxus x 'Green Gem'	18"-24"	S																		
GVV	22	Green Velvet Boxwood / Buxus 'Green Velvet'	18"-24"	S																		
GLS	40	Green Low Fragrant Sumac / Rhus aromatica 'Green Low'	5 gal	S																		
LH	15	LimeLight Hydrangea / Hydrangea paniculata 'LimeLight' TM	5 gal	S																		
LLHYD	24	Little Lime Hydrangea / Hydrangea paniculata 'Little Lime'	5 gal	S																		
RCA	7	Rose Creek Abelia / Abelia x grandiflora 'Rose Creek'	5 gal	S																		
SBKE	7	Sonic Bloom Heigela / Weigela Florida 'Sonic Bloom'	5 gal	S																		

ANNUALS/PERENNIALS	QTY	COMMON / BOTANICAL NAME	SIZE	A	Slow	Moderate	Fast	< 6"	6" - 18"	18" - 36"	> 3'	< 18"	3 - 6'	6 - 10'	10 - 15'	> 15'	< 15'	15 - 25'	25 - 40'	40 - 65'	> 65'	
YL	42	Variegated Liriope / Liriope muscari 'Variegata'	1 gal	A																		

FORBS	QTY	COMMON / BOTANICAL NAME	SIZE	F	Slow	Moderate	Fast	< 6"	6" - 18"	18" - 36"	> 3'	< 18"	3 - 6'	6 - 10'	10 - 15'	> 15'	< 15'	15 - 25'	25 - 40'	40 - 65'	> 65'	
CI	454	Copper Iris / Iris fulva Louisiana'	2 qt. @ 18" OC	F																		
OBS	230	Ozark Blue Star / Amsonia illustris	2 qt. @ 30" OC	F																		
ROSEM	355	Rose Mallow / Hibiscus laevis	1 gal @ 30" OC	F																		
SMN	745	Swamp Milkweed / Asclepias incarnata	2 qt. @ 24" OC	F																		

GRASSES	QTY	COMMON / BOTANICAL NAME	SIZE	G	Slow	Moderate	Fast	< 6"	6" - 18"	18" - 36"	> 3'	< 18"	3 - 6'	6 - 10'	10 - 15'	> 15'	< 15'	15 - 25'	25 - 40'	40 - 65'	> 65'	
DPS	8	Dwarf Fountain Grass / Fennisetum alopecuroides 'Hemlin'	5 gal	G																		

GROUND COVERS	QTY	COMMON / BOTANICAL NAME	SIZE	C	Slow	Moderate	Fast	< 6"	6" - 18"	18" - 36"	> 3'	< 18"	3 - 6'	6 - 10'	10 - 15'	> 15'	< 15'	15 - 25'	25 - 40'	40 - 65'	> 65'	
OSB	235	Orange Stonewall / Sedum kamauchotium	2.25" Pot	C																		

NATIVE GRASSES	QTY	COMMON / BOTANICAL NAME	SIZE	N	Slow	Moderate	Fast	< 6"	6" - 18"	18" - 36"	> 3'	< 18"	3 - 6'	6 - 10'	10 - 15'	> 15'	< 15'	15 - 25'	25 - 40'	40 - 65'	> 65'	
FFS	410	Brown Fox Sedge / Carex vulpinoidea	Plug at 18" OC	N																		
RTA	474	Great Green Bulrush / Scirpus atrovirens	Plug at 18" OC	N																		
FRG	745	Morning Star Sedge / Carex grayi	Plug at 18" OC	N																		
PTA	226	Palm Sedge / Carex muskingumensis	Plug at 18" OC	N																		

PERENNIALS	QTY	COMMON / BOTANICAL NAME	SIZE	P	Slow	Moderate	Fast	< 6"	6" - 18"	18" - 36"	> 3'	< 18"	3 - 6'	6 - 10'	10 - 15'	> 15'	< 15'	15 - 25'	25 - 40'	40 - 65'	> 65'	
124 TOTAL				P																		

MIXED POLLINATOR BEDS ALONG NORTH EDGE OF PARKING LOT TO INCLUDE:

- 135 PURPLE CONEFLOWER
- 105 BLACK-EYED SUSAN
- 70 HAPPY RETURNS DAYLILY
- 50 AUTUMN JOY SEDUM

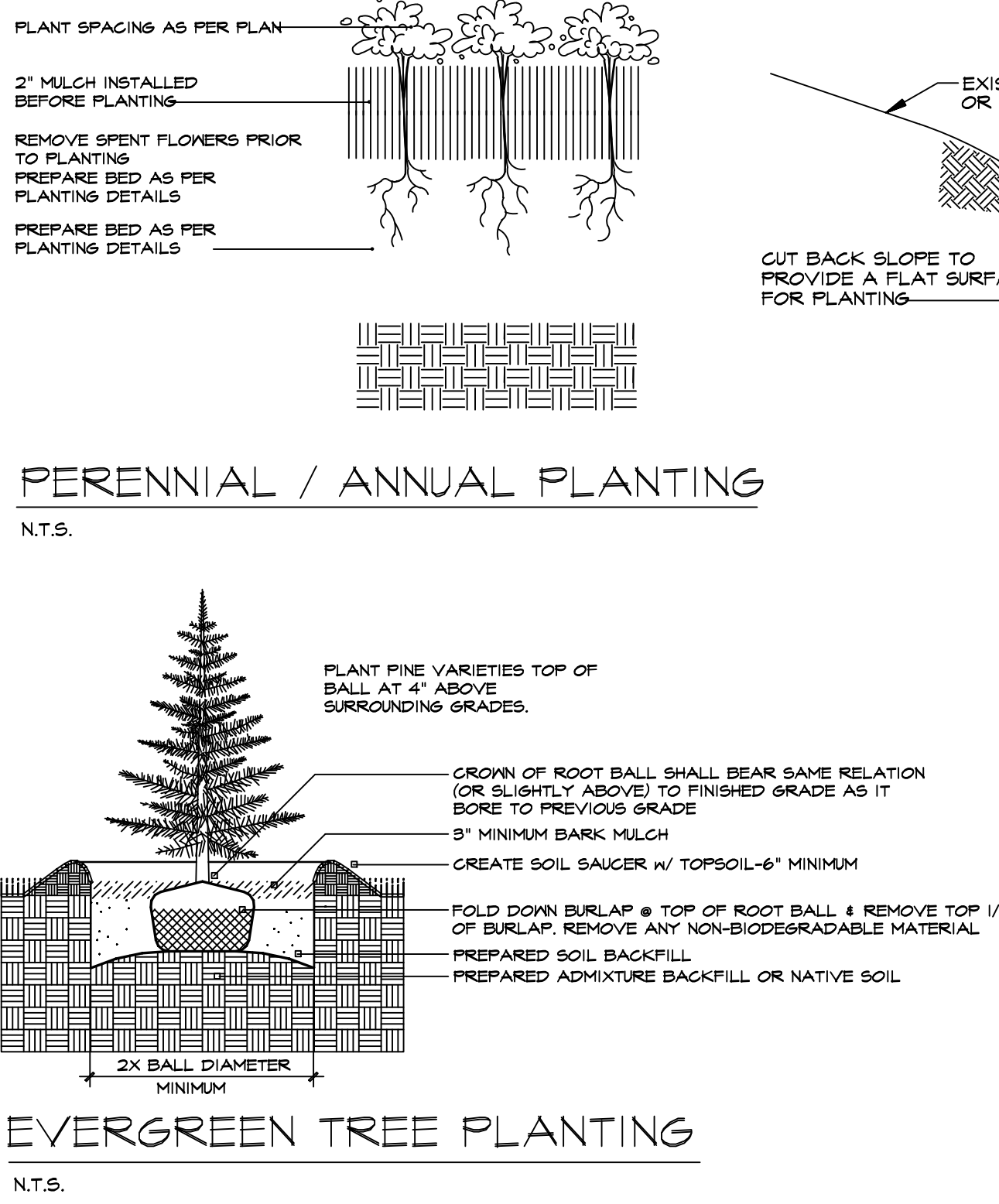
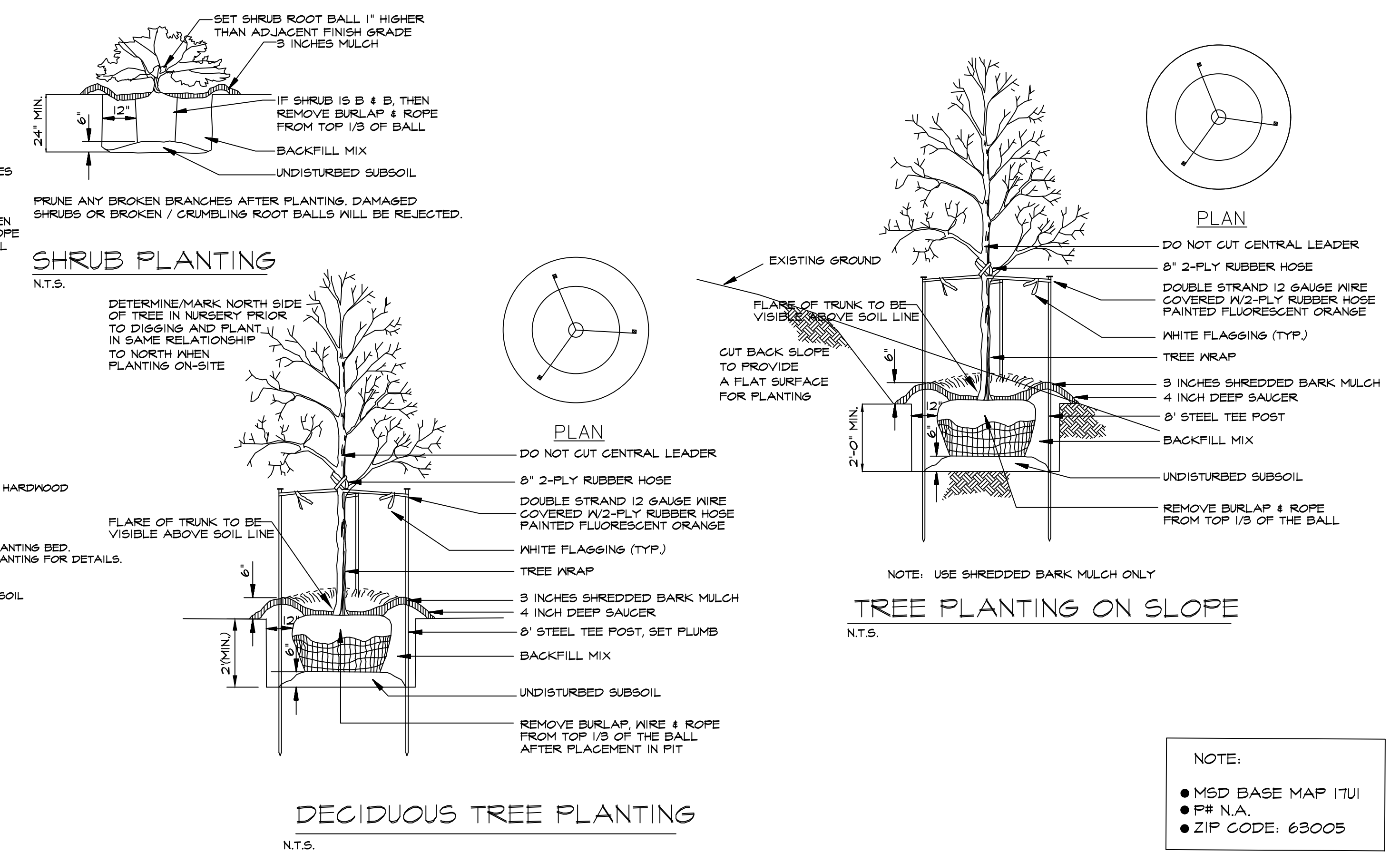
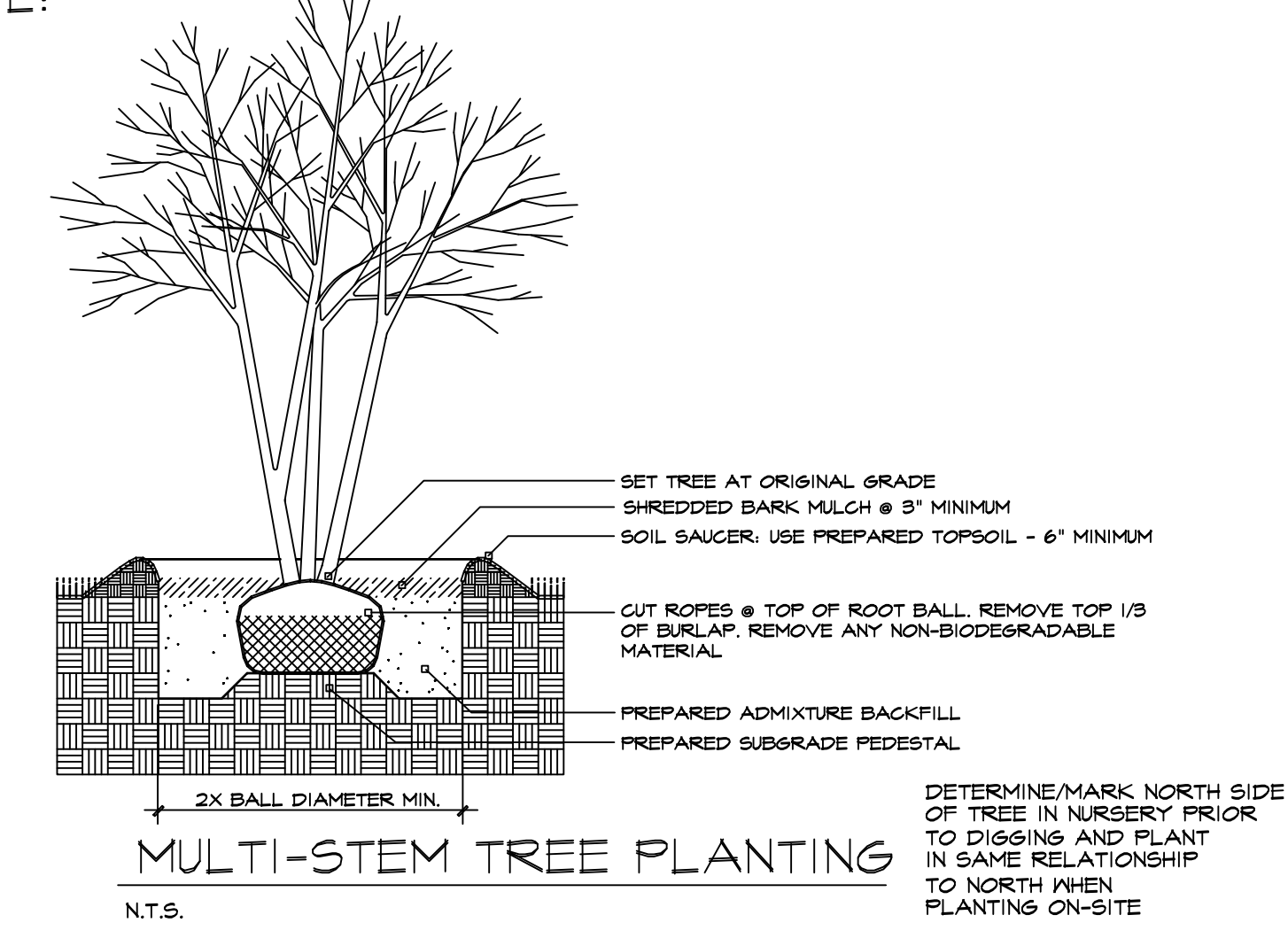

REVISIONS	BY
12/9/19	RAM
1/28/2020	RAM
2/10/2020	RAM
2/18/2020	RAM
2/21/2020	RAM
2/24/2020	RAM
3/13/2020	RAM

*Landscape*

TECHNOLOGIES

61 Jacobs Creek Drive  
Mishouri, MO 63050  
NO Landscape Architectural Corporation #202003028

**Landscape**

REGISTERED PROFESSIONAL LANDSCAPE ARCHITECT  
NO. 133174  
DATE: 5/19/2020

**MASTER PLANTING PLAN FOR THE PROPOSED**

**Jaguar Land Rover Chesterfield**

1 JAGUAR LAND ROVER WAY. CHESTERFIELD, MO 63005

DRAWN R. MARDIS  
CHECKED RYM/HL  
DATE 12/16/19  
SCALE N.T.S. / 1"=40'-0"  
JOB NO. 2019-176  
SHEET

**L-3**  
OF THREE SHEETS

- NOTE:
- MSD BASE MAP 17UI
  - PI N.A.
  - ZIP CODE: 63005



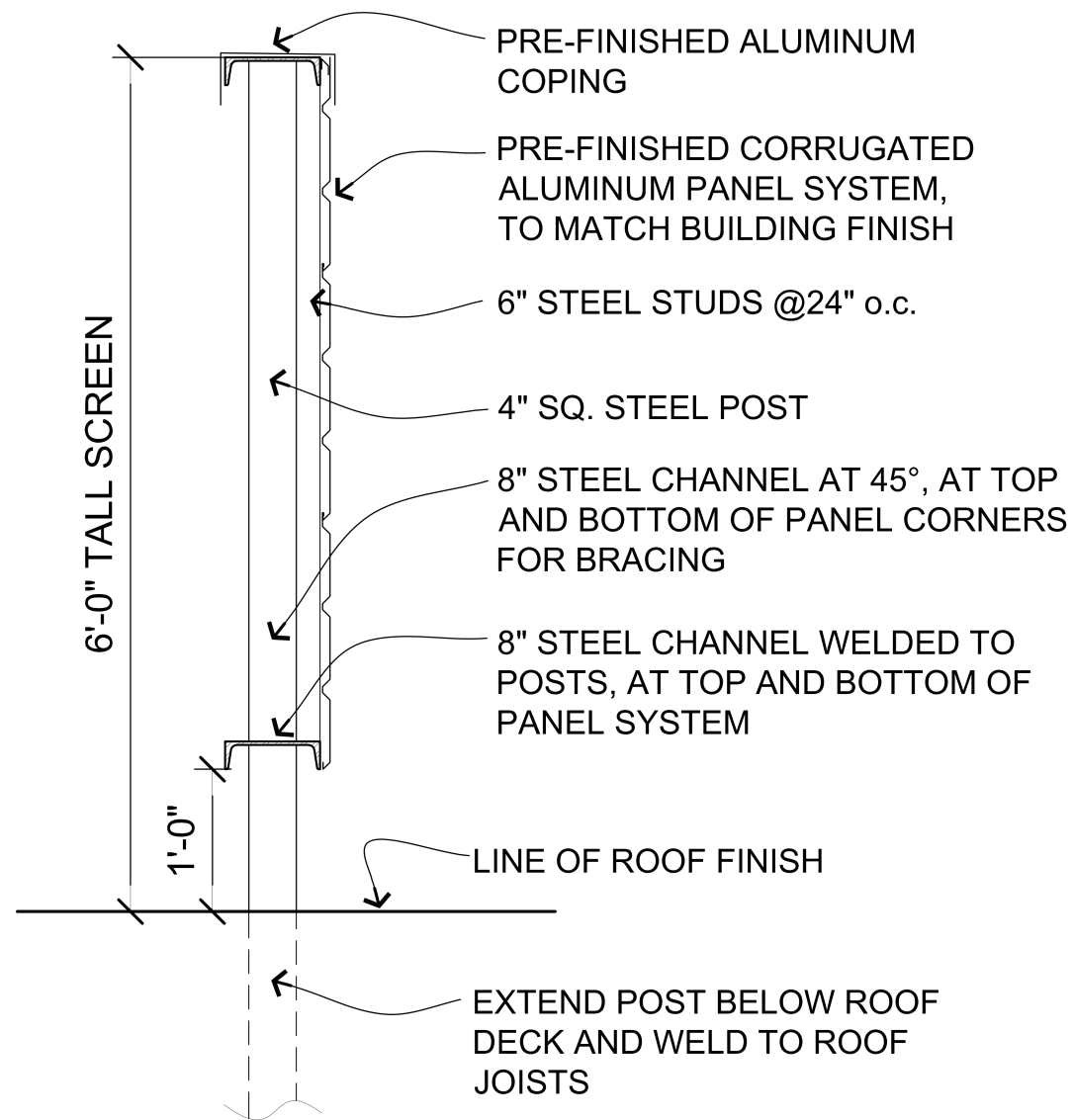

## ROOFTOP HVAC SCREENING SECTION

SCALE:  $\frac{3}{4}$ " = 1'-0"

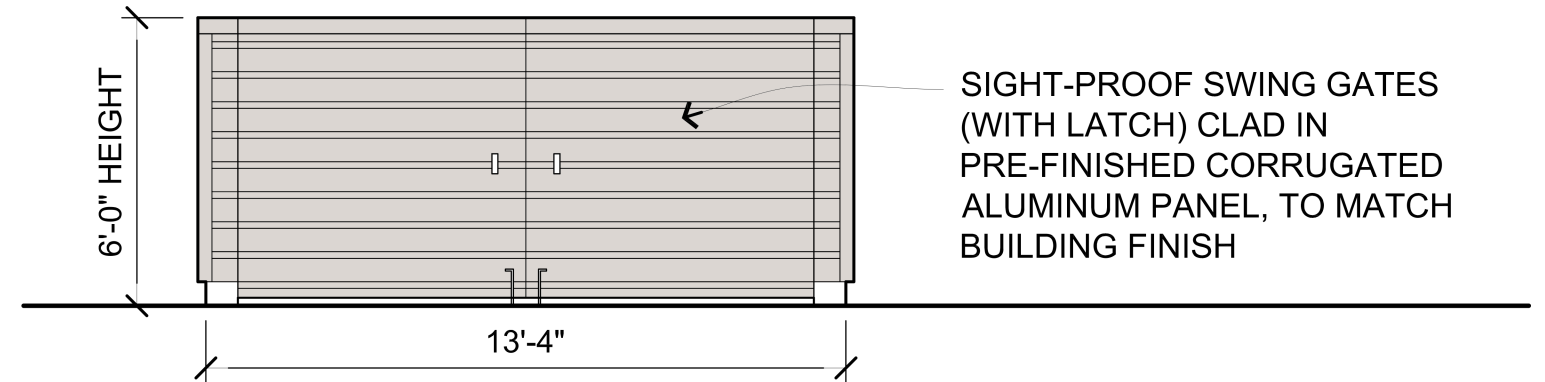

## TRASH ENCLOSURE FRONT ELEVATION

SCALE:  $\frac{1}{4}$ " = 1'-0"

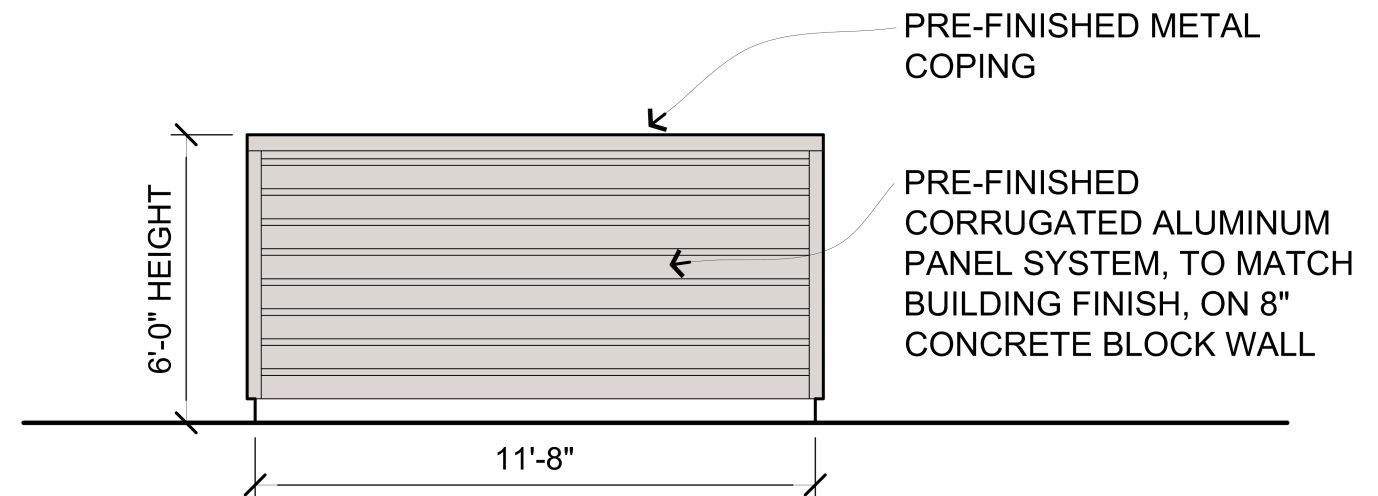

## TRASH ENCLOSURE SIDE ELEVATION

SCALE:  $\frac{1}{4}$ " = 1'-0"



# JAGUAR/LAND ROVER CHESTERFIELD



RECEIVED  
City of Chesterfield  
Apr 28 2020  
Department of Public Services

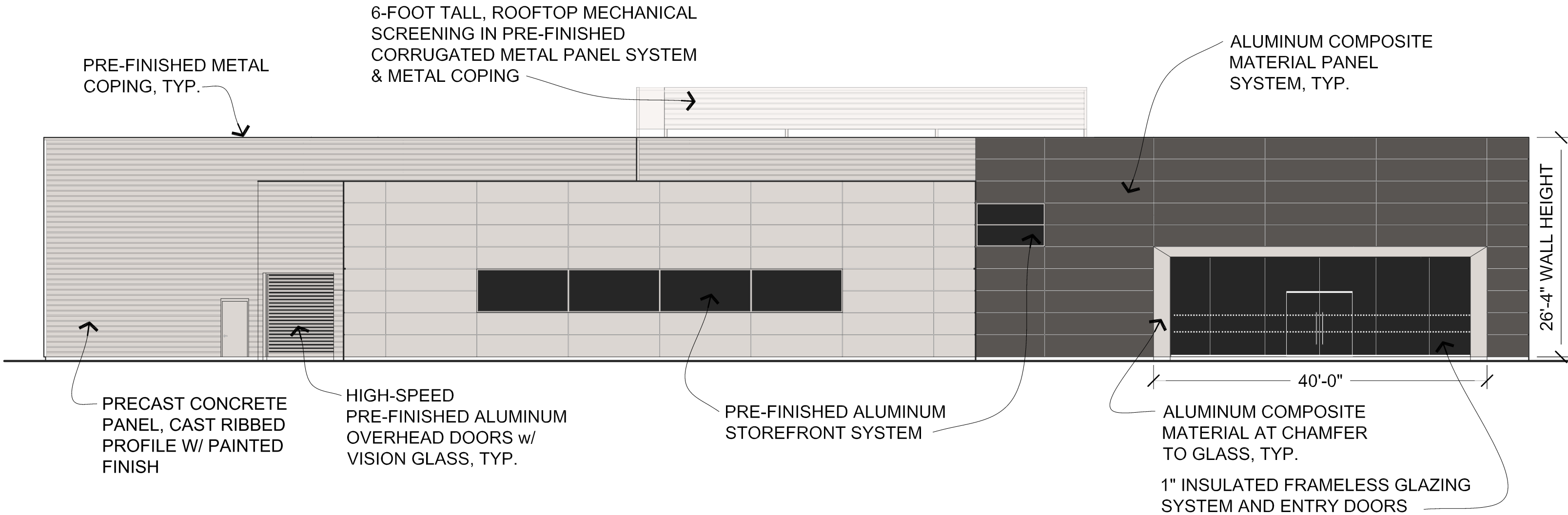

**EAST ELEVATION**

**JAGUAR/LAND ROVER  
CHESTERFIELD**



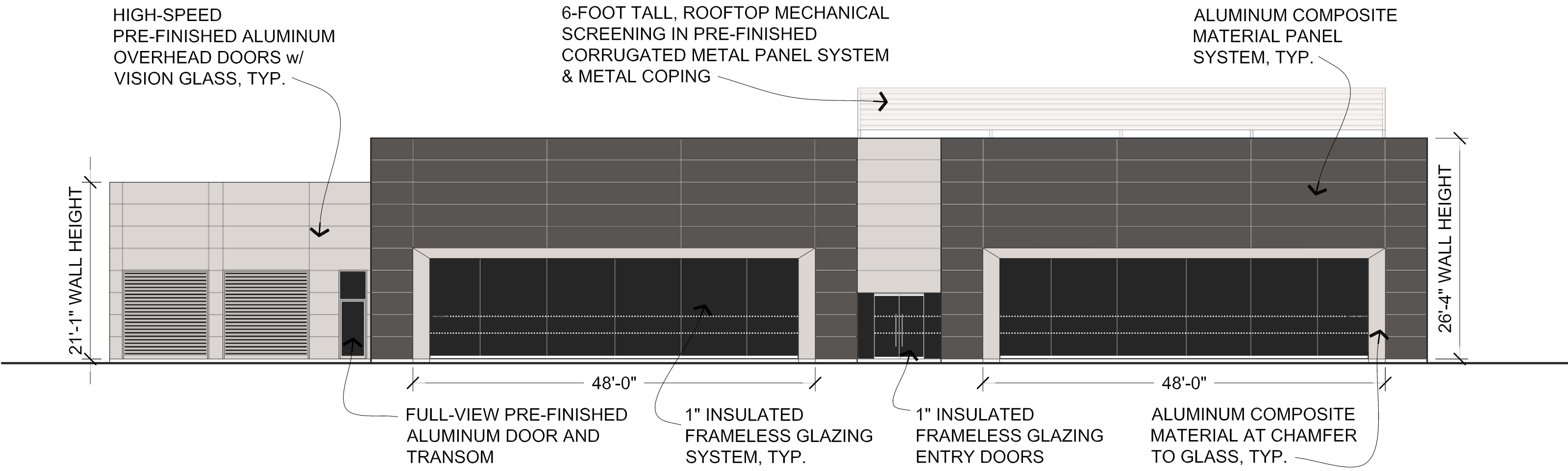

**NORTH ELEVATION**

**JAGUAR/LAND ROVER  
CHESTERFIELD**



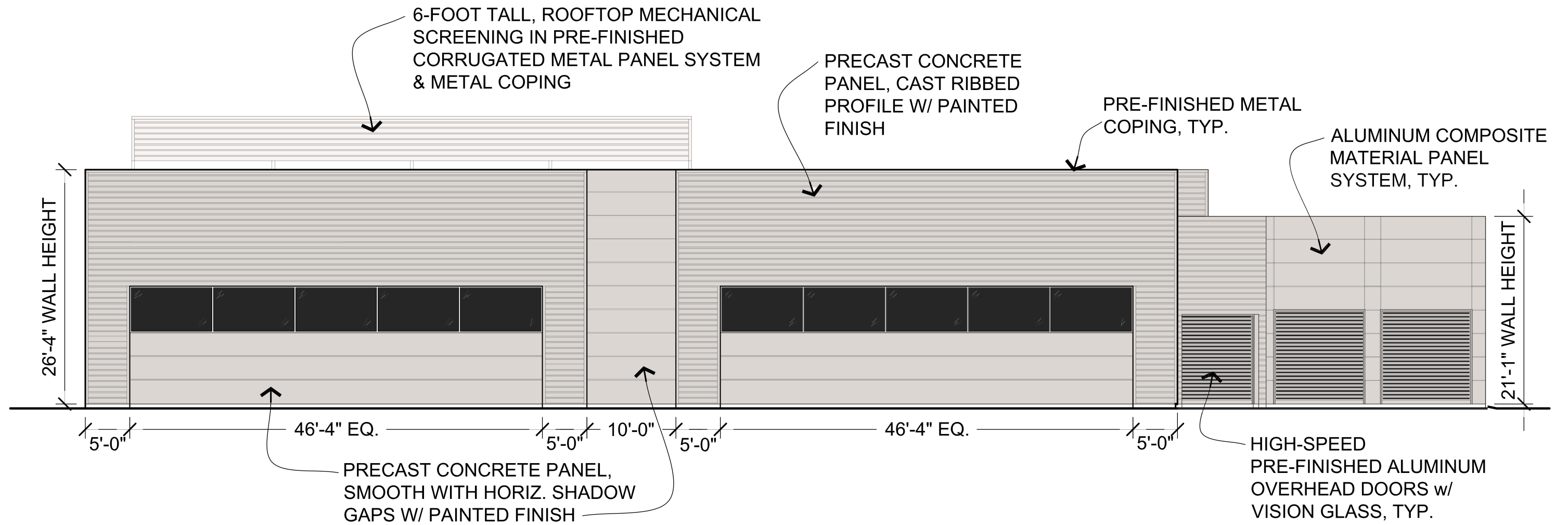

**SOUTH ELEVATION**

**JAGUAR/LAND ROVER  
CHESTERFIELD**



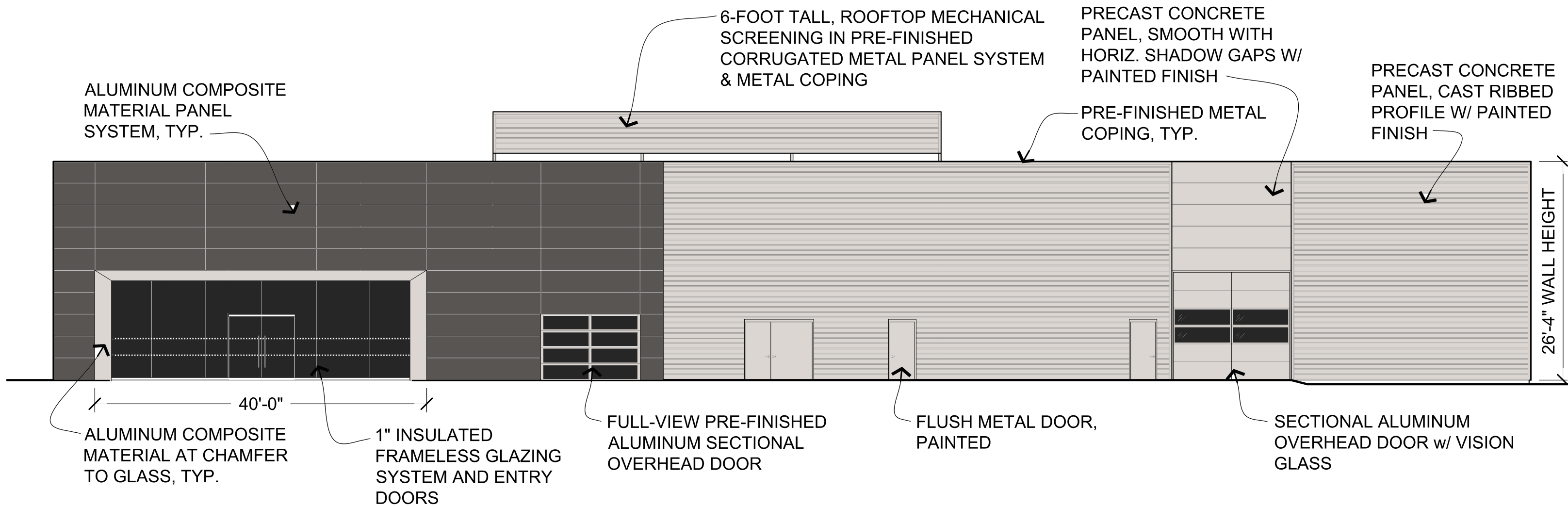

**WEST ELEVATION**

**JAGUAR/LAND ROVER  
CHESTERFIELD**



**RECEIVED**  
City of Chesterfield

**Apr 28 2020**

Department of Public Services

















**STOCK & ASSOCIATES**  
**Consulting Engineers, Inc.**

April 14, 2020

Via Email: (akumerow@chesterfield.mo.us)

City of Chesterfield  
690 Chesterfield Pkwy  
Chesterfield, MO 63005



Attention: Ms. Annisa Kumerow - Planner

Re: TSG Chesterfield Airport Road, Lot 1 SDSP (Jaguar Land Rover) – Response Letter  
(Stock Project No. (218-6407.4))

Dear Annisa,

We are pleased to offer the following written responses to your comments contained within your departmental letter, dated 04/07/2020.

**SDSP Comments**

1. A permanent sidewalk easement is required for the proposed sidewalk along the Arnage Road frontage. The record plat for the TSG Chesterfield Airport Road Subdivision is currently under review and the easement can be dedicated on the plat or it can be dedicated by way of a separate document prior to approval of the improvement plans for Lot A. A template standalone easement document is attached to this memo. Either way, the easement must be depicted on the site development section plan. Provide clarification as to how you would like to proceed on this issue.

**Response: The permanent sidewalk easement has been added to the Record Plat and shown also on the included Site Development Section Plan.**

2. The current plan depicts security gates across both entrances. The gates must meet the requirements of City Code Section 31-04-10, section D, item 6. Code requires a minimum 60-foot stacking distance and a turnaround for rejected vehicles, provided in advance of the gate, designed to accommodate a single unit truck. Please provide backup documentation that these requirements have been met and revise the plan as necessary.

**Response: The gates have been removed from the drawings.**

3. Per Unified Development Code § 31-04-02K.2.(a), landscape buffers shall contain a combination of deciduous trees, evergreen trees, ornamental trees and shrubs and should enhance and preserve native vegetation. Revise the landscape buffer as necessary to include a mix of vegetation.

**Response: Pursuant to the conversation on 04/10/20 the Landscape Plan included in the**

**257 Chesterfield Business Parkway, St. Louis, MO 63005  
636.530.9100 – Main | 636.530.9130 – Fax  
www.stockassoc.com | general@stockassoc.com**



submittal includes the necessary plantings for the landscape buffer.

4. As depicted on the current plat, Lot F is an undevelopable lot. Similar to what has been done for the existing portions of Arnage Road to the east, a cross access easement should be established across the necessary lots to establish the roadway. The site development section plan along with the record plat should be revised such that lot lines are adjusted to eliminate Lot F and depict a cross access easement across the necessary lots.

Response: A copy of the provisions in the PSA regarding Ownership & Maintenance of the Road, provided previously via email, has been included in this submittal. It is the intent to leave the roadway as Lot F, as shown.

### Elevation Comments

1. The Architectural Review Board recommended approval with conditions on March 12th, 2020. The recommendations were as follows:
  - o To further enhance the concept of a four-sided building that has equal attractiveness of architectural elements on the front façade (show room) with the sides and rear (service area).
  - o Introduce a higher quality material, possibly the concrete tilt up panel vs. the corrugated metal as a primary material

In order to meet the Architectural Review Board's recommendation, revise the west elevation as necessary to create a more uniform and integrated elevation.

Response: The west elevation has gone through two changes since the last submittal. The first is a change to the exterior materials. The areas previously clad in corrugated metal panels have been revised to architectural precast concrete. The corrugated metal panels have been eliminated from the facades of all sides of the building and only remain at the rooftop mechanical screen walls. The second change is revising the architectural precast panels above the service door to a smooth finish painted to match the aluminum composite panels that are above the Front Entry on the North elevation. These changes have been negotiated and approved via Jaguar Land Rover corporate procedures. Additional changes will most likely not be approved by Jaguar Land Rover.



2. The South elevation depicts two triangles that are not called out on the elevations. For reference, see the image below. Revise the elevation as necessary to include a call out for this item.

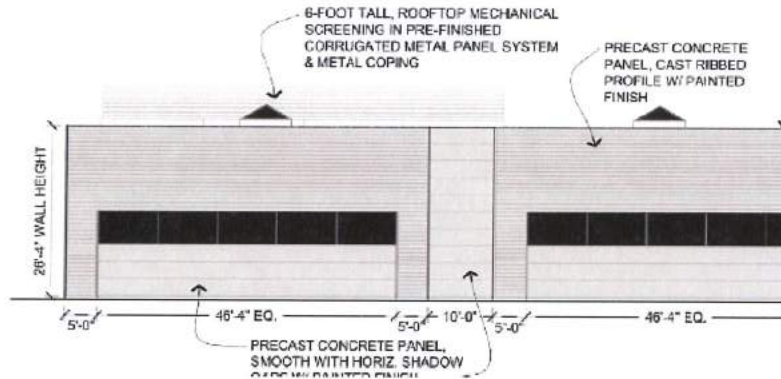

**Response:** The triangles referenced and as seen on the South Elevation are pyramidal skylights above the service department. The Owner has opted to remove these skylights since there have been windows added to the South Elevation. This change is reflected within the enclosed submittal.

As always, we appreciate your continued assistance and support for this project. Should you have any question or comments, please feel free to call.

Sincerely,

*Josh Barcus*

Joshuah Barcus, P.E.

Associate

CC: Jordan Aron ([jaron@imperialmotors.com](mailto:jaron@imperialmotors.com)), Green Bay Properties LLC  
Sam Adler ([sadler@tsgproperties.com](mailto:sadler@tsgproperties.com)), TSG Chesterfield Airport Road LLC  
Bob Flubacker ([rfaltd@aol.com](mailto:rfaltd@aol.com)), Robert Flu backer Architects "RFA" Limited  
George Stock, P.E., President  
Kate Stock Gitto, P.E., Project Manager  
Todd Ehlen, P.E., Associate  
John Willems, P.E., Associate



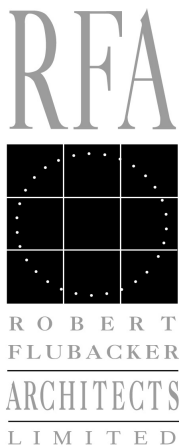

Annisa Kumerow  
Planner  
City of Chesterfield  
690 Chesterfield Parkway West  
Chesterfield, Missouri 63005

March 2, 2020

RE: Jaquar / Land Rover Chesterfield  
31 Arnage Road  
Chesterfield, Missouri 63005



Dear Ms. Kumerow,

This letter shall serve to address some issues that have been brought up by both staff and the Architectural Review Board relating to the above referenced project.

1835 Rohlwing Road

**I Unified Development Code Requirements**

The first area I would like to address is a slide from our hearing on February 13, 2020. This slide had four items listed as “Unified Development Code requirements” and I would like to address them individually.

Suite B

1. *Parking: Locate parking primarily to the side or rear of any building facade facing I-64/US 40 or along North Outer 40.*

Rolling Meadows, IL 60008

This issue was discussed at the hearing. The parking in front of the North Facade of the facility is customer parking with inventory and vehicles awaiting service located at the sides and rear of the facility. The Board excepted this situation.

847-704-3200

2. *Facade: Utilize architectural elements from the front facade on the side and rear of the structure.*

rfaltd@aol.com

The building design utilizes three major building materials. These are as follows:

- A. A large glazed storefront wall of glass for view into the showroom areas.
- B. Aluminum Composite Panels that clad the customer accessed portions of the building. These areas include the showroom and related offices, the Service Reception area and the Service write-up area.
- C. Corrugated metal panels which clad the non-customer accessed areas of the building (or back-of-house spaces). These areas include the Service department, Parts Department and related spaces.

The design of the building specifically utilizes these materials to indicate the functions of the building within. The building is not a



monolithic box with one function which lends itself to the use of consistent materials on all parts of the building. The differing materials gives the building an identifiable organization and provides the customer a degree of wayfinding to locate and enter into the portions of the building which have the more refined finishes. To arbitrarily apply materials from the customer accessed portions of the building to other areas will confuse and diminish this design pattern.

3. *Storage: Screen outdoor storage of goods, equipment or automobiles for sale or service from I-64.*

Again, this item was discussed at the hearing and the design of the parking areas with the storage of vehicles primarily on the sides and rear was acceptable.

4. *Commercial: Locate Service and loading areas away from public streets, if not possible, utilize the street with the least traffic volume and visual impact.*

There was some discussion at the hearing regarding the overhead doors at the Service Reception area that face I-64. I would like to expound on this issue. First, these doors are not service doors. There are no deliveries or products that will enter the building through these doors. These are customer entry doors into the Service Reception area. Customers will drive their vehicle into this staging area for the facility staff to greet and accept the vehicle for service work. In a typical day it is likely that more customers enter the building through these doors than will enter through the main entry doors at the middle of the Showroom. These doors are also predominately glass. They are fast-acting overhead doors similar to the doors in the picture below:





Additionally these doors are 60 feet behind the front facade and significantly downplayed as a dominant. In fact these doors are not visible from traffic Eastbound on I-64 and difficult to see from traffic westbound.

## **II. Building Materials**

The second topic I would like to discuss is the reluctance to approve the metal panel portions of the building. I have the following points to make related to this issue:

1. The City has referenced code requirement, section 31-04-01 Paragraph D3 which references Materials and Colors. In particular, this paragraph lists “Highly reflective materials and prefabricated buildings are discouraged”. I would like to point out that the metal panels do not fit into this description. The panels have a paint finish much like any of the other building materials used, such as precast concrete panels, EIFS or painted/stained masonry units. The finish is not reflective at all. Additionally, the metal panel facing does not classify this building as a prefabricated structure. The metal panels are merely a facing material made off site and erected at the job site similar to precast concrete panels or even masonry units. There was discussion at the hearing of potentially adding an additional material to the building but in my opinion this would greatly diminish the clarity of design discussed previously in this letter.

## **III South Facade**

The Board made it clear at the hearing that the South Facade of the building was unacceptable and required more visual interest. The design has been amended to include windows and recesses on the South facade utilized in the same proportions as the Showroom fenestration to provide visual interest in this wall. A nine foot landscape area has also been added in front of the South facade to provide more visual interest and color in front of the building wall. These changes were discussed at the hearing and were generally looked on with favor by the Board.

I suggest that in light of the changes made and the support discussion in this letter that the Board would provide the approval of the submitted design. Please feel free to contact me should you have any questions, comments or concerns.



Annisa Kumerow  
March 2, 2020  
Page No. 4

Very truly yours,  
ROBERT FLUBACKER ARCHITECTS, LTD.

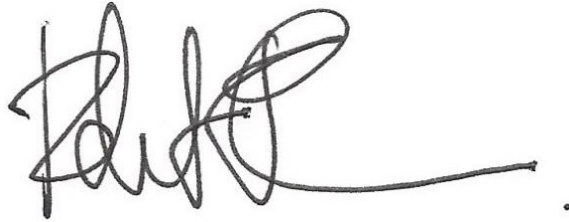
A handwritten signature in black ink, appearing to read 'R. Flubacker', with a long horizontal line extending to the right and a small dot at the end.

Robert Flubacker, AIA  
President



# RFA

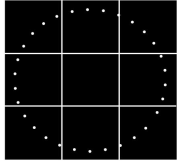

ROBERT  
FLUBACKER  
ARCHITECTS  
LIMITED

1835 Rohlwing Road

Suite B

Rolling Meadows, IL 60008

847-704-3200

rfaltd@aol.com



Justin Wyse, AICP  
Senior Planner  
City of Chesterfield  
690 Chesterfield Parkway West  
Chesterfield, Missouri 63005

December 31, 2019

RE: Jaquar / Land Rover Chesterfield  
31 Arnage Road  
Chesterfield, Missouri 63005

Dear Mr. Wyse,

This letter and attached documents shall comprise our submittal to the City of Chesterfield Architectural Review Board for the above referenced project. I appreciate your review of the material and look forward to any questions or comments you may have.

The balance of this letter shall serve as our Architect's Statement of Design indicating the intent of the project and how we are addressing each section of the Architectural Design Standards.

## **I Intent of the Project**

The proposed building project is to result in a new Jaquar and Land Rover automobile dealership. The site is approximately 8.73 acres located a short block North of Chesterfield Airport Road and just West of Arnage Boulevard. The Northern boundary of the property is the right-of-way for U.S. Route 64. The building size is approximately 31,000 GSF containing retail showroom and sales offices, vehicle service facilities, parts storage and miscellaneous support spaces. The building is predominately a one-story facility with a mezzanine of approximately 5,000 GSF. The main facade of the building will face U.S. Route 64. The balance of the site is made up of vehicular parking, vehicular traffic circulation and landscaped areas.



## **II**      **General Requirements for Site Design**

1.      Site Relationship  
The project site is situated South of U.S. Route 64 providing the primary visibility of the site to vehicular traffic. Access to the site is via Arnage Road using either Arnage Boulevard or an access road to the West of Auto Zone off of Chesterfield Airport Road. The proposed retail use of the property is consistent with the immediate as well as the general surrounding areas.
2.      Circulation system and access.  
The building is located generally in the middle of the property with two - way access drives on all sides providing for easy vehicular access to all areas of the building and parking. Customer parking is located on the North end of the property at the most convenient location for entry into the primary sales areas.
3.      Topography  
The subject property is relatively flat and is only being modified to provide properly designed storm water storage and drainage.
4.      Retaining Walls  
The proposed development does not currently require the use of any retaining walls.

## **III**      **General Requirements for Building Design**

1.      Scale  
The building size and height is generally similar and consistent with buildings in the area. There are large open parking areas and landscape areas that separate the building from adjacent properties providing a buffer between the proposed project and existing buildings.
2.      Design  
The building design is part of a global design standard for the brands of automobiles being sold and serviced at this facility. The design has been created to accentuate the high-end elegance, as well as, the technological focus of the vehicles.
3.      Materials and Colors.  
The major materials are aluminum composite panels, aluminum building panels and a large format butt-glazed glass showroom wall. The materials are consistently used on all four sides of the building. The colors of the

aluminum components are generally a silver gray. Material samples will be available at the design review meeting.

4. **Landscape Design and Screening**  
The landscaping has been designed to focus attention on the building and eliminate obstructed views from U.S. Route 64. The parking areas are landscaped with oversized islands to minimize the impact of debris from trees affecting the finishes of the parked cars. The intent is to create and maintain a landscaped environment consistent with the level of automobile being represented.
5. **Signage**  
Signage will be submitted as part of a separate application. Signage is a part of the global design standard and is available upon request. Signage will also address directional wayfinding for visitors to the site.
6. **Lighting**  
The site lighting has been designed to highlight the vehicles parked (displayed) and to provide a high level of site security. The building is minimally lit to draw the eye into the showroom and vehicles displayed and illuminated in the showroom during the evening hours.

#### **IV Specific Requirements for Chesterfield Valley**

##### **Facades**

The building facade will utilize consistent materials on all sides. The building frontage on U.S. Route 64 will be minimally lit, again, to draw the eye to the interior of the showroom. The trash enclosure will be screened with materials consistent with the exterior materials of the building.

##### **Storage**

There is no exterior storage with the exception of the vehicular parking of new and used inventory. The intent of the site configuration is for customer parking to be the only parking between the building and U.S. Route 64 therefore providing an unencumbered view of the showroom during off hours.

##### **Utilities**

All building utilities will be provided via underground methods.

##### **Parking**

Parking is an integral part of the display of vehicles and is designed as



Justin Wyse  
December 31, 2019  
Page No. 4

such. The site plan provides for large open green spaces to provide a buffer to adjacent properties. The loading doors for the facility are seldom used and do not require screening.

Thank you for the opportunity to submit this project for your consideration. Please feel free to contact me should you have any questions, comments or concerns.

Very truly yours,  
ROBERT FLUBACKER ARCHITECTS, LTD.

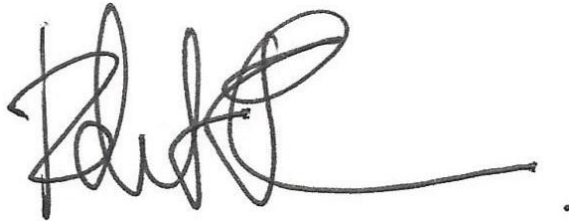
A handwritten signature in black ink, appearing to read 'R. Flubacker', with a long horizontal line extending to the right.

Robert Flubacker, AIA  
President

## DESCRIPTION

The Galleon™ LED luminaire delivers exceptional performance in a highly scalable, low-profile design. Patented, high-efficiency AccuLED Optics™ system provides uniform and energy conscious illumination to walkways, parking lots, roadways, building areas and security lighting applications. IP66 rated and UL/cUL Listed for wet locations.

Catalog #	
Project	
Comments	
Prepared by	

**RECEIVED**  
City of Chesterfield

**Apr 28 2020**

Department of Public Services

## SPECIFICATION FEATURES

### Construction

Extruded aluminum driver enclosure thermally isolated from Light Squares for optimal thermal performance. Heavy-wall, die-cast aluminum end caps enclose housing and die-cast aluminum heat sinks. A unique, patent pending interlocking housing and heat sink provides scalability with superior structural rigidity. 3G vibration tested and rated. Optional tool-less hardware available for ease of entry into electrical chamber. Housing is IP66 rated.

### Optics

Patented, high-efficiency injection-molded AccuLED Optics technology. Optics are precisely designed to shape the distribution maximizing efficiency and application spacing. AccuLED Optics create consistent distributions with the scalability to meet customized application requirements. Offered standard in 4000K (+/- 275K) CCT 70 CRI. Optional 3000K, 5000K and 6000K CCT.

### Electrical

LED drivers are mounted to removable tray assembly for ease of maintenance. 120-277V 50/60Hz, 347V 60Hz or 480V 60Hz operation. 480V is compatible for use with 480V Wye systems only. Standard with 0-10V dimming. Shipped standard with Eaton proprietary circuit module designed to withstand 10kV of transient line surge. The Galleon LED luminaire is suitable for operation in -40°C to 40°C ambient environments. For applications with ambient temperatures exceeding 40°C, specify the HA (High Ambient) option. Light Squares are IP66 rated. Greater than 90% lumen maintenance expected at 60,000 hours. Available in standard 1A drive current and optional 600mA, 800mA and 1200mA drive currents (nominal).

### Mounting

**STANDARD ARM MOUNT:** Extruded aluminum arm includes internal bolt guides allowing for easy positioning of fixture during mounting. When mounting two or more luminaires at 90° and 120° apart, the EA extended arm may be required. Refer to the

arm mounting requirement table. Round pole adapter included. For wall mounting, specify wall mount bracket option. **QUICK MOUNT ARM:** Adapter is bolted directly to the pole. Quick mount arm slide into place on the adapter and is secured via two screws, facilitating quick and easy installation. The versatile, patent pending, quick mount arm accommodates multiple drill patterns ranging from 1-1/2" to 4-7/8". Removal of the door on the quick mount arm enables wiring of the fixture without having to access the driver compartment. A knock-out enables round pole mounting.

### Finish

Housing finished in super durable TGIC polyester powder coat paint, 2.5 mil nominal thickness for superior protection against fade and wear. Heat sink is powder coated black. Standard housing colors include black, bronze, grey, white, dark platinum and graphite metallic. RAL and custom color matches available.

### Warranty

Five-year warranty.



## GLEON GALLEON LED

1-10 Light Squares  
Solid State LED

AREA/SITE LUMINAIRE



LumenSafe Technology  
[CLICK HERE](#)

WaveLinx

## DIMENSIONS

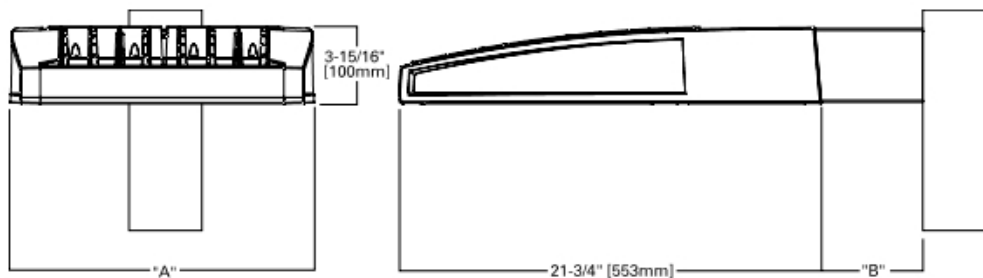

## DIMENSION DATA

Number of Light Squares	"A" Width	"B" Standard Arm Length	"B" Optional Arm Length <sup>1</sup>	Weight with Arm (lbs.)	EPA with Arm <sup>2</sup> (Sq. Ft.)
1-4	15-1/2" (394mm)	7" (178mm)	10" (254mm)	33 (15.0 kgs.)	0.96
5-6	21-5/8" (549mm)	7" (178mm)	10" (254mm)	44 (20.0 kgs.)	1.00
7-8	27-5/8" (702mm)	7" (178mm)	13" (330mm)	54 (24.5 kgs.)	1.07
9-10	33-3/4" (857mm)	7" (178mm)	16" (406mm)	63 (28.6 kgs.)	1.12

NOTES: 1. Optional arm length to be used when mounting two fixtures at 90° on a single pole. 2. EPA calculated with optional arm length.

## DRILLING PATTERN

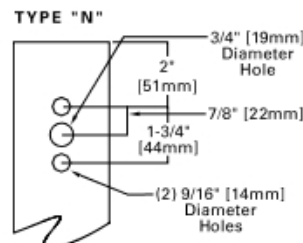

## CERTIFICATION DATA

3G Vibration Rated  
DesignLights Consortium® Qualified\*  
IP66 Rated  
ISO 9001  
LM79 / LM80 Compliant  
UL/cUL Wet Location Listed

## ENERGY DATA

**Electronic LED Driver**  
>0.9 Power Factor  
<20% Total Harmonic Distortion  
120V-277V 50/60Hz  
347V, 480V 60Hz  
-40°C Min. Temperature  
40°C Max. Temperature  
50°C Max. Temperature (HA Option)



**ARM MOUNTING REQUIREMENTS**

Configuration	90° Apart	120° Apart
GLEON-AF-01	7" Arm (Standard)	7" Arm (Standard)
GLEON-AF-02	7" Arm (Standard)	7" Arm (Standard)
GLEON-AF-03	7" Arm (Standard)	7" Arm (Standard)
GLEON-AF-04	7" Arm (Standard)	7" Arm (Standard)
GLEON-AF-05	10" Extended Arm (Required)	7" Arm (Standard)
GLEON-AF-06	10" Extended Arm (Required)	7" Arm (Standard)
GLEON-AF-07	13" Extended Arm (Required)	13" Extended Arm (Required)
GLEON-AF-08	13" Extended Arm (Required)	13" Extended Arm (Required)
GLEON-AF-09	16" Extended Arm (Required)	16" Extended Arm (Required)
GLEON-AF-10	16" Extended Arm (Required)	16" Extended Arm (Required)

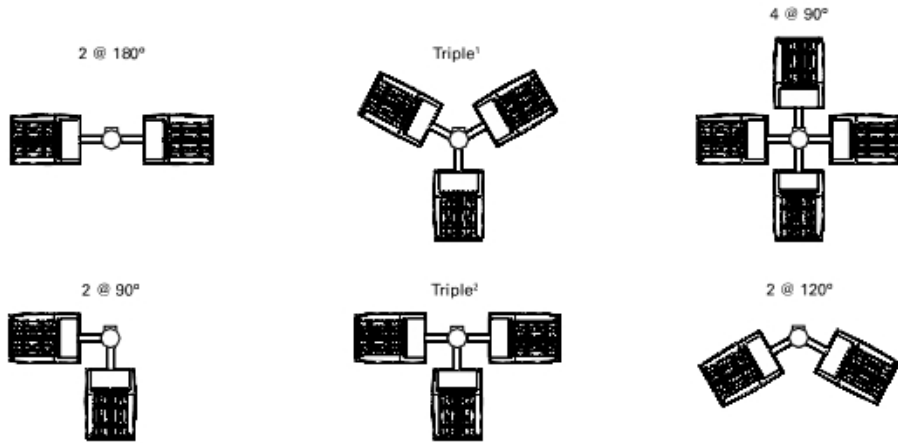

**NOTES:** 1 Round poles are 3 @ 120°. Square poles are 3 @ 90°. 2 Round poles are 3 @ 90°.

**STANDARD WALL MOUNT**

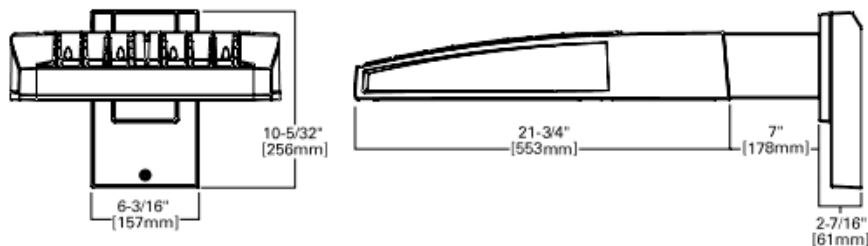

**MAST ARM MOUNT**

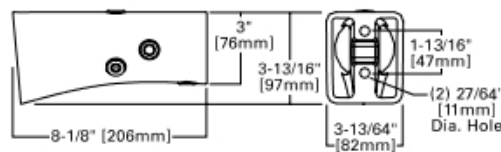

**QUICK MOUNT ARM (INCLUDES FIXTURE ADAPTER)**

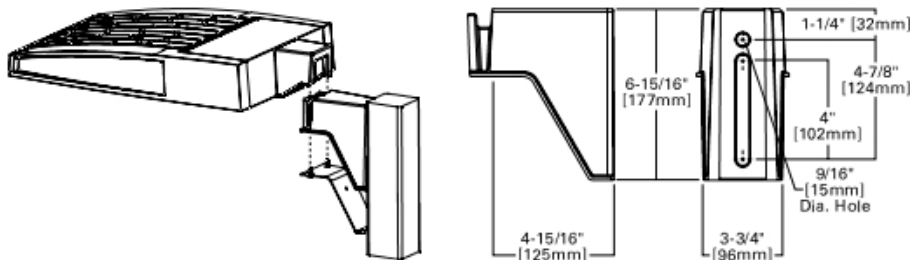

**QM Quick Mount Arm (Standard)**

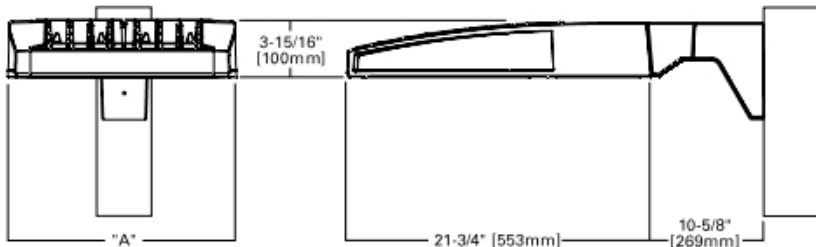

**QMEA Quick Mount Arm (Extended)**

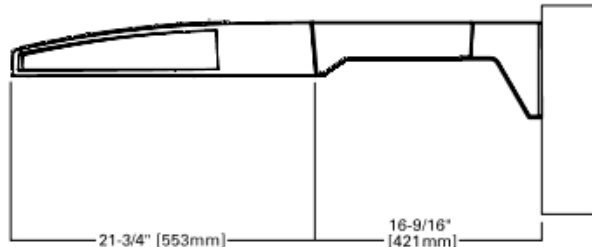

**QUICK MOUNT ARM DATA**

Number of Light Squares <sup>1,2</sup>	"A" Width	Weight with QM Arm (lbs.)	Weight with QMEA Arm (lbs.)	EPA (Sq. Ft.)
1-4	15-1/2" (394mm)	35 (15.91 kgs.)	38 (17.27 kgs.)	1.11
5-6 <sup>3</sup>	21-5/8" (549mm)	46 (20.91 kgs.)	49 (22.27 kgs.)	
7-8	27-5/8" (702mm)	56 (25.45 kgs.)	N/A	

**NOTES:** 1 QM option available with 1-8 light square configurations. 2 QMEA option available with 1-6 light square configurations. 3 QMEA arm to be used when mounting two fixtures at 90° on a single pole.

**OPTIC ORIENTATION**

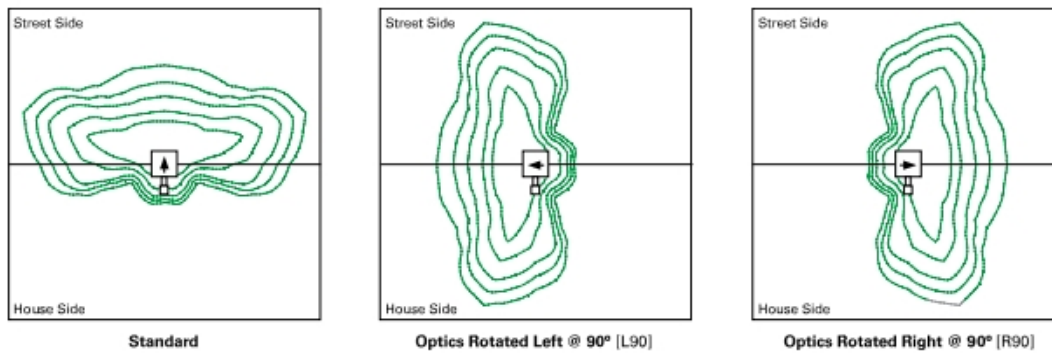

**OPTICAL DISTRIBUTIONS**

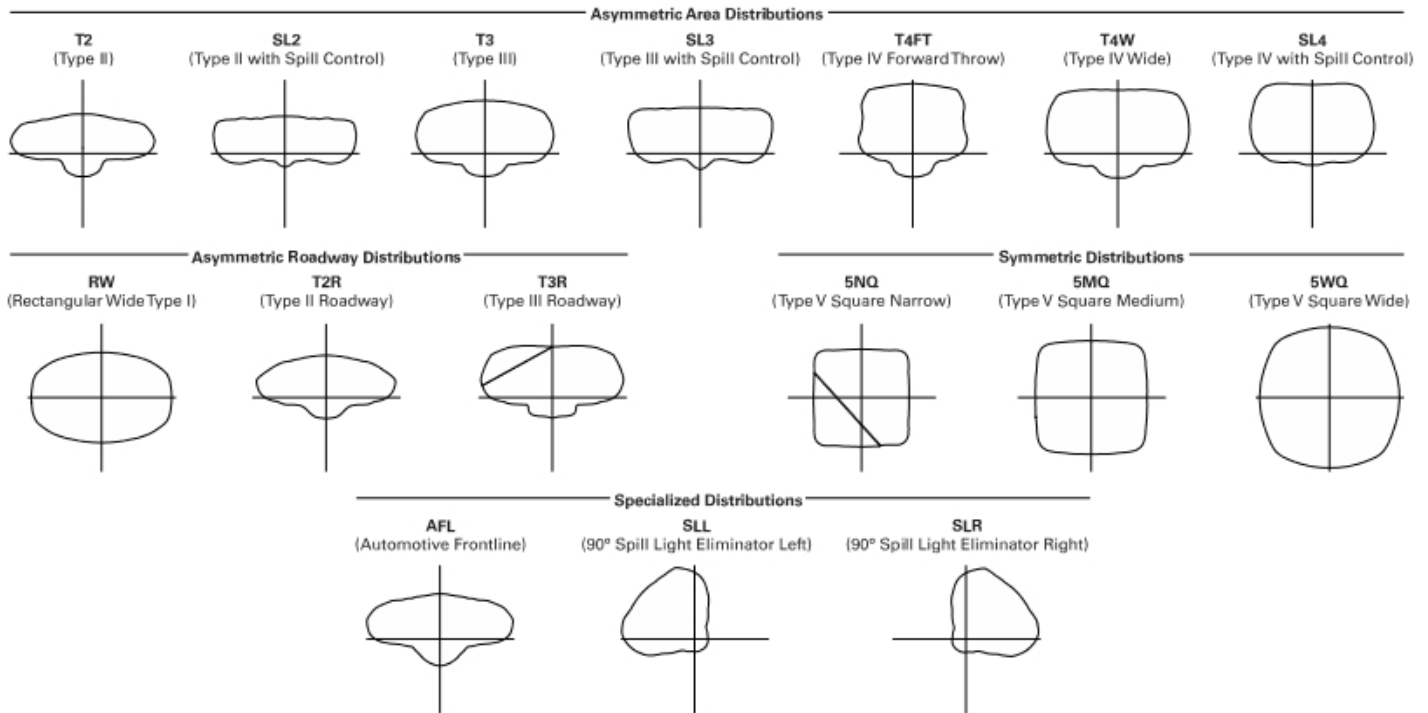

**LUMEN MAINTENANCE**

Drive Current	Ambient Temperature	TM-21 Lumen Maintenance (60,000 Hours)	Projected L70 (Hours)
Up to 1A	Up to 50°C	> 95%	416,000
1.2A	Up to 40°C	> 90%	205,000

**LUMEN MULTIPLIER**

Ambient Temperature	Lumen Multiplier
0°C	1.02
10°C	1.01
25°C	1.00
40°C	0.99
50°C	0.97

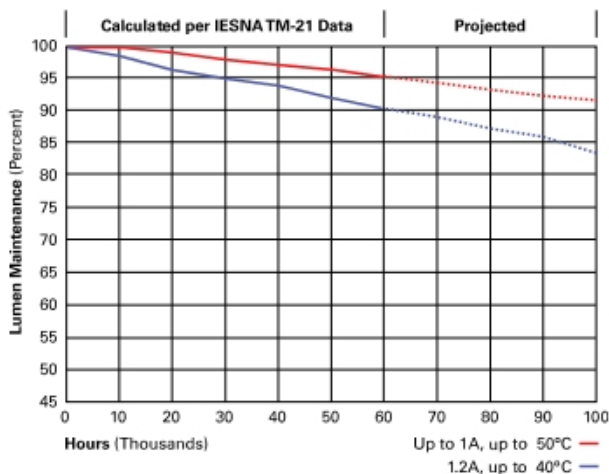



**NOMINAL POWER LUMENS (1.2A)**

Number of Light Squares	1	2	3	4	5	6	7	8	9	10	
<b>Nominal Power (Watts)</b>	67	129	191	258	320	382	448	511	575	640	
<b>Input Current @ 120V (A)</b>	0.58	1.16	1.78	2.31	2.94	3.56	4.09	4.71	5.34	5.87	
<b>Input Current @ 208V (A)</b>	0.33	0.63	0.93	1.27	1.57	1.87	2.22	2.52	2.8	3.14	
<b>Input Current @ 240V (A)</b>	0.29	0.55	0.80	1.10	1.35	1.61	1.93	2.18	2.41	2.71	
<b>Input Current @ 277V (A)</b>	0.25	0.48	0.70	0.96	1.18	1.39	1.69	1.90	2.09	2.36	
<b>Input Current @ 347V (A)</b>	0.20	0.39	0.57	0.78	0.96	1.15	1.36	1.54	1.72	1.92	
<b>Input Current @ 480V (A)</b>	0.15	0.30	0.43	0.60	0.73	0.85	1.03	1.16	1.28	1.45	
<b>Optics</b>											
<b>T2</b>	4000K/5000K Lumens	6,863	13,412	20,011	26,441	32,761	39,205	46,364	52,534	58,601	64,880
	3000K Lumens	6,489	12,681	18,919	25,000	30,974	37,066	43,836	49,668	55,405	61,341
	BUG Rating	B1-U0-G2	B2-U0-G2	B3-U0-G3	B3-U0-G4	B3-U0-G4	B3-U0-G4	B4-U0-G5	B4-U0-G5	B4-U0-G5	B4-U0-G5
<b>T2R</b>	4000K/5000K Lumens	7,285	14,238	21,246	28,072	34,780	41,621	49,221	55,770	62,212	68,878
	3000K Lumens	6,888	13,462	20,087	26,541	32,884	39,351	46,537	52,729	58,819	65,122
	BUG Rating	B1-U0-G1	B2-U0-G2	B2-U0-G3	B3-U0-G3	B3-U0-G4	B3-U0-G4	B3-U0-G4	B3-U0-G5	B4-U0-G5	B4-U0-G5
<b>T3</b>	4000K/5000K Lumens	6,995	13,670	20,397	26,951	33,391	39,959	47,256	53,544	59,728	66,130
	3000K Lumens	6,613	12,924	19,284	25,480	31,570	37,780	44,679	50,624	56,471	62,524
	BUG Rating	B1-U0-G2	B2-U0-G2	B3-U0-G3	B3-U0-G4	B3-U0-G4	B3-U0-G5	B4-U0-G5	B4-U0-G5	B4-U0-G5	B4-U0-G5
<b>T3R</b>	4000K/5000K Lumens	7,150	13,973	20,850	27,549	34,134	40,846	48,307	54,734	61,056	67,598
	3000K Lumens	6,761	13,212	19,713	26,046	32,272	38,619	45,673	51,750	57,726	63,911
	BUG Rating	B1-U0-G2	B2-U0-G2	B2-U0-G3	B3-U0-G4	B3-U0-G4	B3-U0-G5	B3-U0-G5	B3-U0-G5	B4-U0-G5	B4-U0-G5
<b>T4FT</b>	4000K/5000K Lumens	7,036	13,748	20,515	27,107	33,586	40,191	47,530	53,854	60,074	66,512
	3000K Lumens	6,652	12,999	19,397	25,629	31,754	37,999	44,938	50,917	56,797	62,885
	BUG Rating	B1-U0-G2	B2-U0-G3	B2-U0-G4	B3-U0-G4	B3-U0-G5	B3-U0-G5	B3-U0-G5	B3-U0-G5	B4-U0-G5	B4-U0-G5
<b>T4W</b>	4000K/5000K Lumens	6,945	13,571	20,249	26,756	33,152	39,671	46,917	53,160	59,298	65,653
	3000K Lumens	6,566	12,831	19,146	25,297	31,344	37,508	44,358	50,260	56,064	62,072
	BUG Rating	B1-U0-G2	B2-U0-G3	B3-U0-G4	B3-U0-G4	B3-U0-G5	B3-U0-G5	B4-U0-G5	B4-U0-G5	B4-U0-G5	B4-U0-G5
<b>SL2</b>	4000K/5000K Lumens	6,851	13,388	19,977	26,396	32,704	39,137	46,283	52,444	58,498	64,768
	3000K Lumens	6,477	12,658	18,888	24,957	30,920	37,003	43,759	49,584	55,308	61,235
	BUG Rating	B1-U0-G2	B2-U0-G3	B3-U0-G3	B3-U0-G4	B3-U0-G4	B3-U0-G5	B4-U0-G5	B4-U0-G5	B4-U0-G5	B4-U0-G5
<b>SL3</b>	4000K/5000K Lumens	6,994	13,668	20,394	26,947	33,388	39,953	47,249	53,537	59,720	66,119
	3000K Lumens	6,612	12,922	19,281	25,477	31,567	37,774	44,673	50,618	56,463	62,514
	BUG Rating	B1-U0-G2	B2-U0-G3	B2-U0-G3	B3-U0-G4	B3-U0-G5	B3-U0-G5	B3-U0-G5	B3-U0-G5	B4-U0-G5	B4-U0-G5
<b>SL4</b>	4000K/5000K Lumens	6,645	12,986	19,378	25,603	31,723	37,962	44,893	50,868	56,743	62,824
	3000K Lumens	6,282	12,279	18,321	24,207	29,993	35,892	42,445	48,094	53,648	59,398
	BUG Rating	B1-U0-G2	B1-U0-G3	B2-U0-G4	B2-U0-G4	B2-U0-G5	B3-U0-G5	B3-U0-G5	B3-U0-G5	B3-U0-G5	B3-U0-G5
<b>5NQ</b>	4000K/5000K Lumens	7,214	14,097	21,036	27,795	34,437	41,210	48,734	55,220	61,597	68,199
	3000K Lumens	6,820	13,329	19,888	26,279	32,558	38,962	46,077	52,208	58,237	64,479
	BUG Rating	B3-U0-G1	B3-U0-G2	B4-U0-G2	B4-U0-G2	B5-U0-G2	B5-U0-G3	B5-U0-G3	B5-U0-G4	B5-U0-G4	B5-U0-G4
<b>5MQ</b>	4000K/5000K Lumens	7,347	14,356	21,423	28,306	35,071	41,969	49,632	56,237	62,730	69,454
	3000K Lumens	6,947	13,573	20,254	26,762	33,158	39,680	46,925	53,170	59,309	65,667
	BUG Rating	B3-U0-G1	B4-U0-G2	B4-U0-G2	B5-U0-G3	B5-U0-G4	B5-U0-G4	B5-U0-G4	B5-U0-G5	B5-U0-G5	B5-U0-G5
<b>5WQ</b>	4000K/5000K Lumens	7,366	14,396	21,480	28,381	35,164	42,080	49,765	56,386	62,898	69,639
	3000K Lumens	6,964	13,610	20,308	26,833	33,247	39,786	47,050	53,311	59,468	65,842
	BUG Rating	B3-U0-G2	B4-U0-G2	B5-U0-G3	B5-U0-G4	B5-U0-G4	B5-U0-G4	B5-U0-G5	B5-U0-G5	B5-U0-G5	B5-U0-G5
<b>SL/SLR</b>	4000K/5000K Lumens	6,147	12,010	17,921	23,679	29,339	35,109	41,521	47,046	52,478	58,102
	3000K Lumens	5,811	11,355	16,944	22,388	27,739	33,194	39,256	44,479	49,617	54,933
	BUG Rating	B1-U0-G2	B2-U0-G3	B2-U0-G3	B3-U0-G4	B3-U0-G4	B3-U0-G5	B3-U0-G5	B3-U0-G5	B3-U0-G5	B3-U0-G5
<b>RW</b>	4000K/5000K Lumens	7,149	13,970	20,846	27,543	34,126	40,837	48,295	54,722	61,042	67,582
	3000K Lumens	6,760	13,208	19,709	26,041	32,264	38,610	45,661	51,738	57,713	63,897
	BUG Rating	B3-U0-G1	B3-U0-G2	B4-U0-G2	B4-U0-G2	B5-U0-G3	B5-U0-G3	B5-U0-G4	B5-U0-G4	B5-U0-G4	B5-U0-G4
<b>AFL</b>	4000K/5000K Lumens	7,175	14,021	20,921	27,643	34,249	40,986	48,470	54,920	61,262	67,828
	3000K Lumens	6,784	13,256	19,780	26,136	32,381	38,750	45,827	51,925	57,922	64,129
	BUG Rating	B1-U0-G1	B2-U0-G2	B2-U0-G2	B3-U0-G3	B3-U0-G3	B3-U0-G3	B3-U0-G3	B3-U0-G3	B4-U0-G4	B4-U0-G4

\* Nominal data for 70 CRI.

**NOMINAL POWER LUMENS (1A)**

Number of Light Squares	1	2	3	4	5	6	7	8	9	10	
<b>Nominal Power (Watts)</b>	59	113	166	225	279	333	391	445	501	558	
<b>Input Current @ 120V (A)</b>	0.51	1.02	1.53	2.03	2.55	3.06	3.56	4.08	4.60	5.07	
<b>Input Current @ 208V (A)</b>	0.29	0.56	0.82	1.11	1.37	1.64	1.93	2.19	2.46	2.75	
<b>Input Current @ 240V (A)</b>	0.26	0.48	0.71	0.96	1.19	0.41	1.67	1.89	2.12	2.39	
<b>Input Current @ 277V (A)</b>	0.23	0.42	0.61	0.83	1.03	1.23	1.45	1.65	1.84	2.09	
<b>Input Current @ 347V (A)</b>	0.17	0.32	0.50	0.64	0.82	1.00	1.14	1.32	1.50	1.68	
<b>Input Current @ 480V (A)</b>	0.14	0.24	0.37	0.48	0.61	0.75	0.91	0.99	1.12	1.28	
<b>Optics</b>											
<b>T2</b>	4000K/5000K Lumens	6,256	12,225	18,242	24,104	29,865	35,739	42,265	47,888	53,420	59,144
	3000K Lumens	5,915	11,559	17,248	22,789	28,236	33,790	39,960	45,277	50,506	55,919
	BUG Rating	B1-U0-G2	B2-U0-G2	B3-U0-G3	B3-U0-G4	B3-U0-G4	B3-U0-G4	B4-U0-G5	B4-U0-G5	B4-U0-G5	B4-U0-G5
<b>T2R</b>	4000K/5000K Lumens	6,642	12,979	19,366	25,589	31,705	37,941	44,870	50,940	56,711	62,789
	3000K Lumens	6,280	12,271	18,311	24,193	29,976	35,872	42,423	48,068	53,619	59,365
	BUG Rating	B1-U0-G1	B2-U0-G2	B2-U0-G2	B3-U0-G3	B3-U0-G4	B3-U0-G4	B3-U0-G4	B3-U0-G5	B4-U0-G5	B4-U0-G5
<b>T3</b>	4000K/5000K Lumens	6,377	12,461	18,593	24,568	30,439	36,426	43,077	48,810	54,447	60,282
	3000K Lumens	6,029	11,781	17,580	23,229	28,781	34,441	40,731	46,150	51,480	56,997
	BUG Rating	B1-U0-G2	B2-U0-G2	B3-U0-G3	B3-U0-G4	B3-U0-G4	B3-U0-G5	B4-U0-G5	B4-U0-G5	B4-U0-G5	B4-U0-G5
<b>T3R</b>	4000K/5000K Lumens	6,518	12,739	19,006	25,113	31,116	37,235	44,036	49,895	55,658	61,622
	3000K Lumens	6,029	11,781	17,579	23,229	28,779	34,440	40,729	46,148	51,478	56,995
	BUG Rating	B1-U0-G2	B2-U0-G2	B2-U0-G3	B3-U0-G4	B3-U0-G4	B3-U0-G5	B3-U0-G5	B3-U0-G5	B4-U0-G5	B4-U0-G5
<b>T4FT</b>	4000K/5000K Lumens	6,414	12,533	18,702	24,710	30,616	36,637	43,328	49,093	54,763	60,631
	3000K Lumens	6,064	11,849	17,681	23,363	28,946	34,638	40,966	46,417	51,776	57,325
	BUG Rating	B1-U0-G2	B2-U0-G3	B2-U0-G4	B3-U0-G4	B3-U0-G5	B3-U0-G5	B3-U0-G5	B3-U0-G5	B4-U0-G5	B4-U0-G5
<b>T4W</b>	4000K/5000K Lumens	6,331	12,372	18,459	24,391	30,221	36,163	42,769	48,459	54,056	59,849
	3000K Lumens	5,986	11,697	17,452	23,061	28,572	34,192	40,436	45,817	51,108	56,585
	BUG Rating	B1-U0-G2	B2-U0-G3	B3-U0-G4	B3-U0-G4	B3-U0-G5	B3-U0-G5	B4-U0-G5	B4-U0-G5	B4-U0-G5	B4-U0-G5
<b>SL2</b>	4000K/5000K Lumens	6,245	12,205	18,212	24,062	29,813	35,677	42,192	47,807	53,326	59,042
	3000K Lumens	5,904	11,539	17,218	22,750	28,187	33,732	39,891	45,199	50,418	55,822
	BUG Rating	B1-U0-G2	B2-U0-G3	B3-U0-G3	B3-U0-G4	B3-U0-G4	B3-U0-G5	B4-U0-G5	B4-U0-G5	B4-U0-G5	B4-U0-G5
<b>SL3</b>	4000K/5000K Lumens	6,376	12,460	18,591	24,564	30,436	36,421	43,072	48,803	54,439	60,273
	3000K Lumens	6,028	11,780	17,578	23,224	28,776	34,435	40,723	46,141	51,471	56,986
	BUG Rating	B1-U0-G2	B2-U0-G3	B2-U0-G3	B3-U0-G4	B3-U0-G4	B3-U0-G5	B3-U0-G5	B3-U0-G5	B4-U0-G5	B4-U0-G5
<b>SL4</b>	4000K/5000K Lumens	6,058	11,838	17,664	23,340	28,918	34,605	40,924	46,370	51,727	57,269
	3000K Lumens	5,727	11,193	16,701	22,067	27,341	32,718	38,692	43,841	48,906	54,146
	BUG Rating	B1-U0-G2	B1-U0-G3	B2-U0-G4	B2-U0-G4	B2-U0-G5	B3-U0-G5	B3-U0-G5	B3-U0-G5	B3-U0-G5	B3-U0-G5
<b>5NQ</b>	4000K/5000K Lumens	6,577	12,851	19,176	25,336	31,392	37,566	44,426	50,337	56,151	62,170
	3000K Lumens	6,218	12,151	18,131	23,955	29,680	35,517	42,003	47,592	53,089	58,779
	BUG Rating	B2-U0-G1	B3-U0-G2	B4-U0-G2	B4-U0-G2	B5-U0-G2	B5-U0-G3	B5-U0-G3	B5-U0-G3	B5-U0-G4	B5-U0-G4
<b>5MQ</b>	4000K/5000K Lumens	6,697	13,088	19,528	25,803	31,970	38,258	45,243	51,264	57,185	63,313
	3000K Lumens	6,332	12,374	18,463	24,395	30,227	36,171	42,776	48,468	54,066	59,861
	BUG Rating	B3-U0-G1	B4-U0-G2	B4-U0-G2	B5-U0-G3	B5-U0-G4	B5-U0-G4	B5-U0-G4	B5-U0-G5	B5-U0-G5	B5-U0-G5
<b>5WQ</b>	4000K/5000K Lumens	6,715	13,122	19,580	25,871	32,055	38,360	45,365	51,401	57,337	63,482
	3000K Lumens	6,348	12,406	18,513	24,461	30,307	36,268	42,891	48,599	54,210	60,021
	BUG Rating	B3-U0-G2	B4-U0-G2	B5-U0-G3	B5-U0-G3	B5-U0-G4	B5-U0-G4	B5-U0-G5	B5-U0-G5	B5-U0-G5	B5-U0-G5
<b>SL/SLR</b>	4000K/5000K Lumens	5,604	10,949	16,337	21,586	26,745	32,004	37,850	42,886	47,838	52,965
	3000K Lumens	5,298	10,351	15,446	20,409	25,287	30,258	35,786	40,547	45,229	50,077
	BUG Rating	B1-U0-G2	B1-U0-G3	B2-U0-G3	B2-U0-G4	B3-U0-G4	B3-U0-G5	B3-U0-G5	B3-U0-G5	B3-U0-G5	B3-U0-G5
<b>RW</b>	4000K/5000K Lumens	6,517	12,735	19,002	25,107	31,109	37,227	44,025	49,883	55,644	61,607
	3000K Lumens	6,162	12,040	17,965	23,738	29,413	35,197	41,623	47,163	52,609	58,247
	BUG Rating	B3-U0-G1	B3-U0-G2	B4-U0-G2	B4-U0-G2	B5-U0-G3	B5-U0-G3	B5-U0-G3	B5-U0-G4	B5-U0-G4	B5-U0-G4
<b>AFL</b>	4000K/5000K Lumens	6,541	12,781	19,072	25,199	31,221	37,362	44,185	50,065	55,846	61,831
	3000K Lumens	6,184	12,084	18,032	23,825	29,519	35,325	41,775	47,334	52,801	58,459
	BUG Rating	B1-U0-G1	B2-U0-G2	B2-U0-G2	B3-U0-G2	B3-U0-G3	B3-U0-G3	B3-U0-G3	B3-U0-G3	B4-U0-G4	B4-U0-G4

\* Nominal data for 70 CRI.



**NOMINAL POWER LUMENS (800MA)**

Number of Light Squares	1	2	3	4	5	6	7	8	9	10	
<b>Nominal Power (Watts)</b>	44	85	124	171	210	249	295	334	374	419	
<b>Input Current @ 120V (A)</b>	0.39	0.77	1.13	1.54	1.90	2.26	2.67	3.03	3.39	3.80	
<b>Input Current @ 208V (A)</b>	0.22	0.44	0.62	0.88	1.06	1.24	1.50	1.68	1.87	2.12	
<b>Input Current @ 240V (A)</b>	0.19	0.38	0.54	0.76	0.92	1.08	1.30	1.46	1.62	1.84	
<b>Input Current @ 277V (A)</b>	0.17	0.36	0.47	0.72	0.83	0.95	1.19	1.31	1.42	1.67	
<b>Input Current @ 347V (A)</b>	0.15	0.24	0.38	0.49	0.63	0.77	0.87	1.01	1.15	1.52	
<b>Input Current @ 480V (A)</b>	0.11	0.18	0.29	0.37	0.48	0.59	0.66	0.77	0.88	0.96	
<b>Optics</b>											
<b>T2</b>	4000K/5000K Lumens	5,054	9,878	14,739	19,475	24,129	28,875	34,148	38,691	43,159	47,785
	3000K Lumens	4,779	9,338	13,935	18,412	22,813	27,301	32,286	36,581	40,805	45,179
	BUG Rating	B1-U0-G1	B2-U0-G2	B2-U0-G2	B3-U0-G3	B3-U0-G3	B3-U0-G4	B3-U0-G4	B3-U0-G4	B4-U0-G5	B4-U0-G5
<b>T2R</b>	4000K/5000K Lumens	5,366	10,486	15,647	20,675	25,616	30,654	36,252	41,076	45,819	50,730
	3000K Lumens	5,074	9,914	14,794	19,548	24,218	28,982	34,276	38,835	43,320	47,964
	BUG Rating	B1-U0-G1	B1-U0-G2	B2-U0-G2	B2-U0-G2	B3-U0-G3	B3-U0-G3	B3-U0-G4	B3-U0-G4	B3-U0-G4	B3-U0-G5
<b>T3</b>	4000K/5000K Lumens	5,153	10,068	15,022	19,849	24,593	29,430	34,805	39,436	43,990	48,705
	3000K Lumens	4,872	9,519	14,203	18,766	23,251	27,825	32,907	37,285	41,591	46,048
	BUG Rating	B1-U0-G1	B2-U0-G2	B2-U0-G2	B3-U0-G3	B3-U0-G4	B3-U0-G4	B3-U0-G4	B3-U0-G5	B4-U0-G5	B4-U0-G5
<b>T3R</b>	4000K/5000K Lumens	5,266	10,292	15,356	20,290	25,140	30,084	35,578	40,312	44,968	49,786
	3000K Lumens	4,979	9,731	14,518	19,184	23,769	28,443	33,638	38,114	42,516	47,071
	BUG Rating	B1-U0-G2	B1-U0-G2	B2-U0-G3	B2-U0-G3	B3-U0-G4	B3-U0-G4	B3-U0-G5	B3-U0-G5	B3-U0-G5	B3-U0-G5
<b>T4FT</b>	4000K/5000K Lumens	5,182	10,126	15,109	19,964	24,736	29,600	35,006	39,664	44,245	48,987
	3000K Lumens	4,899	9,574	14,285	18,876	23,387	27,986	33,097	37,501	41,832	46,315
	BUG Rating	B1-U0-G2	B1-U0-G2	B2-U0-G3	B2-U0-G4	B3-U0-G4	B3-U0-G4	B3-U0-G5	B3-U0-G5	B3-U0-G5	B3-U0-G5
<b>T4W</b>	4000K/5000K Lumens	5,115	9,995	14,914	19,706	24,417	29,218	34,554	39,152	43,674	48,354
	3000K Lumens	4,836	9,450	14,100	18,631	23,085	27,624	32,670	37,017	41,292	45,717
	BUG Rating	B1-U0-G2	B2-U0-G2	B2-U0-G3	B3-U0-G4	B3-U0-G4	B3-U0-G4	B3-U0-G5	B3-U0-G5	B4-U0-G5	B4-U0-G5
<b>SL2</b>	4000K/5000K Lumens	5,046	9,860	14,713	19,441	24,087	28,825	34,089	38,625	43,085	47,702
	3000K Lumens	4,771	9,322	13,911	18,381	22,774	27,253	32,229	36,518	40,735	45,101
	BUG Rating	B1-U0-G1	B2-U0-G2	B2-U0-G3	B3-U0-G3	B3-U0-G4	B3-U0-G4	B3-U0-G4	B3-U0-G5	B3-U0-G5	B4-U0-G5
<b>SL3</b>	4000K/5000K Lumens	5,152	10,067	15,020	19,846	24,591	29,426	34,800	39,431	43,984	48,698
	3000K Lumens	4,871	9,518	14,200	18,764	23,249	27,822	32,902	37,280	41,585	46,042
	BUG Rating	B1-U0-G2	B1-U0-G2	B2-U0-G3	B2-U0-G3	B3-U0-G4	B3-U0-G4	B3-U0-G5	B3-U0-G5	B3-U0-G5	B3-U0-G5
<b>SL4</b>	4000K/5000K Lumens	4,894	9,565	14,271	18,857	23,364	27,959	33,065	37,465	41,792	46,270
	3000K Lumens	4,627	9,043	13,492	17,829	22,090	26,434	31,261	35,422	39,513	43,746
	BUG Rating	B1-U0-G2	B1-U0-G3	B1-U0-G3	B2-U0-G4	B2-U0-G4	B2-U0-G4	B2-U0-G5	B3-U0-G5	B3-U0-G5	B3-U0-G5
<b>5NQ</b>	4000K/5000K Lumens	5,313	10,383	15,493	20,470	25,363	30,351	35,893	40,669	45,367	50,229
	3000K Lumens	5,024	9,817	14,647	19,354	23,980	28,696	33,936	38,452	42,893	47,490
	BUG Rating	B2-U0-G1	B3-U0-G1	B3-U0-G2	B4-U0-G2	B4-U0-G2	B4-U0-G2	B5-U0-G3	B5-U0-G3	B5-U0-G3	B5-U0-G3
<b>5MQ</b>	4000K/5000K Lumens	5,411	10,574	15,778	20,848	25,830	30,911	36,554	41,418	46,202	51,154
	3000K Lumens	5,117	9,997	14,917	19,710	24,421	29,225	34,561	39,160	43,682	48,364
	BUG Rating	B3-U0-G1	B3-U0-G2	B4-U0-G2	B4-U0-G2	B5-U0-G3	B5-U0-G3	B5-U0-G4	B5-U0-G4	B5-U0-G4	B5-U0-G4
<b>5WQ</b>	4000K/5000K Lumens	5,426	10,603	15,820	20,903	25,899	30,992	36,652	41,529	46,325	51,290
	3000K Lumens	5,130	10,025	14,958	19,763	24,486	29,302	34,654	39,263	43,799	48,493
	BUG Rating	B3-U0-G1	B4-U0-G2	B4-U0-G2	B5-U0-G3	B5-U0-G3	B5-U0-G4	B5-U0-G4	B5-U0-G4	B5-U0-G5	B5-U0-G5
<b>SL/SLR</b>	4000K/5000K Lumens	4,528	8,846	13,199	17,440	21,609	25,858	30,580	34,649	38,651	42,792
	3000K Lumens	4,281	8,364	12,480	16,489	20,430	24,448	28,912	32,759	36,543	40,459
	BUG Rating	B1-U0-G2	B1-U0-G2	B2-U0-G3	B2-U0-G3	B2-U0-G4	B3-U0-G4	B3-U0-G5	B3-U0-G5	B3-U0-G5	B3-U0-G5
<b>RW</b>	4000K/5000K Lumens	5,265	10,289	15,353	20,285	25,134	30,077	35,569	40,303	44,958	49,775
	3000K Lumens	4,978	9,727	14,516	19,179	23,763	28,437	33,629	38,105	42,506	47,060
	BUG Rating	B2-U0-G1	B3-U0-G1	B3-U0-G2	B4-U0-G2	B4-U0-G2	B4-U0-G2	B5-U0-G3	B5-U0-G3	B5-U0-G3	B5-U0-G4
<b>AFL</b>	4000K/5000K Lumens	5,285	10,327	15,409	20,360	25,225	30,186	35,699	40,450	45,120	49,956
	3000K Lumens	4,996	9,763	14,569	19,249	23,849	28,540	33,752	38,244	42,659	47,232
	BUG Rating	B1-U0-G1	B1-U0-G1	B2-U0-G2	B2-U0-G2	B3-U0-G2	B3-U0-G3	B3-U0-G3	B3-U0-G3	B3-U0-G3	B3-U0-G3

\* Nominal data for 70 CRI.

**NOMINAL POWER LUMENS (600MA)**

Number of Light Squares	1	2	3	4	5	6	7	8	9	10	
<b>Nominal Power (Watts)</b>	34	66	96	129	162	193	226	257	290	323	
<b>Input Current @ 120V (A)</b>	0.30	0.58	0.86	1.16	1.44	1.73	2.03	2.33	2.59	2.89	
<b>Input Current @ 208V (A)</b>	0.17	0.34	0.49	0.65	0.84	0.99	1.14	1.30	1.48	1.63	
<b>Input Current @ 240V (A)</b>	0.15	0.30	0.43	0.56	0.74	0.87	1.00	1.13	1.30	1.43	
<b>Input Current @ 277V (A)</b>	0.14	0.28	0.41	0.52	0.69	0.81	0.93	1.04	1.22	1.33	
<b>Input Current @ 347V (A)</b>	0.11	0.19	0.30	0.39	0.49	0.60	0.69	0.77	0.90	0.99	
<b>Input Current @ 480V (A)</b>	0.08	0.15	0.24	0.30	0.38	0.48	0.53	0.59	0.71	0.77	
<b>Optics</b>											
<b>T2</b>	4000K/5000K Lumens	4,121	8,055	12,019	15,881	19,676	23,547	27,847	31,552	35,196	38,967
	3000K Lumens	3,896	7,615	11,363	15,015	18,604	22,263	26,328	29,831	33,276	36,842
	BUG Rating	B1-U0-G1	B1-U0-G2	B2-U0-G2	B2-U0-G2	B3-U0-G3	B3-U0-G3	B3-U0-G4	B3-U0-G4	B3-U0-G4	B3-U0-G4
<b>T2R</b>	4000K/5000K Lumens	4,376	8,552	12,760	16,860	20,890	24,998	29,563	33,497	37,365	41,369
	3000K Lumens	4,138	8,085	12,064	15,941	19,751	23,635	27,951	31,670	35,328	39,113
	BUG Rating	B1-U0-G1	B1-U0-G2	B2-U0-G2	B2-U0-G2	B2-U0-G2	B3-U0-G3	B3-U0-G3	B3-U0-G4	B3-U0-G4	B3-U0-G4
<b>T3</b>	4000K/5000K Lumens	4,201	8,210	12,251	16,187	20,055	23,999	28,383	32,159	35,873	39,718
	3000K Lumens	3,973	7,763	11,583	15,304	18,961	22,691	26,835	30,406	33,916	37,552
	BUG Rating	B1-U0-G1	B1-U0-G2	B2-U0-G2	B2-U0-G3	B3-U0-G3	B3-U0-G4	B3-U0-G4	B3-U0-G4	B3-U0-G4	B3-U0-G5
<b>T3R</b>	4000K/5000K Lumens	4,294	8,393	12,523	16,546	20,501	24,532	29,014	32,875	36,671	40,600
	3000K Lumens	4,060	7,936	11,840	15,644	19,383	23,195	27,432	31,082	34,671	38,386
	BUG Rating	B1-U0-G1	B1-U0-G2	B2-U0-G2	B2-U0-G3	B2-U0-G3	B3-U0-G4	B3-U0-G4	B3-U0-G4	B3-U0-G5	B3-U0-G5
<b>T4FT</b>	4000K/5000K Lumens	4,226	8,257	12,321	16,280	20,172	24,139	28,547	32,346	36,082	39,948
	3000K Lumens	3,996	7,807	11,649	15,392	19,071	22,822	26,990	30,582	34,114	37,770
	BUG Rating	B1-U0-G1	B1-U0-G2	B2-U0-G2	B2-U0-G3	B2-U0-G4	B3-U0-G4	B3-U0-G4	B3-U0-G5	B3-U0-G5	B3-U0-G5
<b>T4W</b>	4000K/5000K Lumens	4,171	8,151	12,162	16,071	19,912	23,827	28,178	31,928	35,615	39,432
	3000K Lumens	3,943	7,706	11,498	15,194	18,825	22,527	26,642	30,187	33,673	37,281
	BUG Rating	B1-U0-G1	B2-U0-G2	B2-U0-G2	B2-U0-G3	B3-U0-G4	B3-U0-G4	B3-U0-G4	B3-U0-G5	B3-U0-G5	B3-U0-G5
<b>SL2</b>	4000K/5000K Lumens	4,114	8,041	11,998	15,854	19,643	23,506	27,799	31,498	35,135	38,901
	3000K Lumens	3,890	7,603	11,344	14,989	18,572	22,224	26,282	29,780	33,219	36,779
	BUG Rating	B1-U0-G1	B1-U0-G2	B2-U0-G3	B2-U0-G3	B3-U0-G3	B3-U0-G4	B3-U0-G4	B3-U0-G4	B3-U0-G4	B3-U0-G5
<b>SL3</b>	4000K/5000K Lumens	4,200	8,209	12,249	16,184	20,053	23,996	28,379	32,154	35,869	39,712
	3000K Lumens	3,972	7,762	11,580	15,302	18,960	22,688	26,831	30,400	33,913	37,546
	BUG Rating	B1-U0-G1	B1-U0-G2	B2-U0-G3	B2-U0-G3	B2-U0-G3	B3-U0-G4	B3-U0-G4	B3-U0-G4	B3-U0-G5	B3-U0-G5
<b>SL4</b>	4000K/5000K Lumens	3,992	7,799	11,638	15,378	19,053	22,801	26,964	30,552	34,081	37,733
	3000K Lumens	3,774	7,374	11,003	14,539	18,015	21,557	25,493	28,886	32,222	35,674
	BUG Rating	B1-U0-G2	B1-U0-G2	B1-U0-G3	B1-U0-G3	B2-U0-G4	B2-U0-G4	B2-U0-G4	B2-U0-G5	B2-U0-G5	B3-U0-G5
<b>5NQ</b>	4000K/5000K Lumens	4,333	8,467	12,634	16,694	20,683	24,751	29,271	33,166	36,996	40,961
	3000K Lumens	4,097	8,005	11,945	15,784	19,555	23,401	27,674	31,357	34,978	38,727
	BUG Rating	B2-U0-G1	B3-U0-G1	B3-U0-G1	B3-U0-G2	B4-U0-G2	B4-U0-G2	B4-U0-G2	B5-U0-G2	B5-U0-G3	B5-U0-G3
<b>5MQ</b>	4000K/5000K Lumens	4,413	8,622	12,867	17,000	21,064	25,207	29,810	33,777	37,677	41,715
	3000K Lumens	4,173	8,152	12,165	16,073	19,915	23,832	28,185	31,934	35,623	39,440
	BUG Rating	B3-U0-G1	B3-U0-G2	B4-U0-G2	B4-U0-G2	B4-U0-G2	B5-U0-G3	B5-U0-G3	B5-U0-G4	B5-U0-G4	B5-U0-G4
<b>5WQ</b>	4000K/5000K Lumens	4,424	8,646	12,900	17,046	21,120	25,274	29,890	33,866	37,778	41,826
	3000K Lumens	4,182	8,175	12,197	16,117	19,968	23,896	28,260	32,018	35,717	39,545
	BUG Rating	B3-U0-G1	B3-U0-G2	B4-U0-G2	B4-U0-G2	B5-U0-G3	B5-U0-G3	B5-U0-G4	B5-U0-G4	B5-U0-G4	B5-U0-G4
<b>SL/SLR</b>	4000K/5000K Lumens	3,692	7,214	10,763	14,222	17,621	21,086	24,937	28,256	31,519	34,897
	3000K Lumens	3,491	6,820	10,176	13,447	16,660	19,937	23,577	26,715	29,800	32,994
	BUG Rating	B1-U0-G1	B1-U0-G2	B1-U0-G3	B2-U0-G3	B2-U0-G3	B2-U0-G4	B3-U0-G4	B3-U0-G4	B3-U0-G5	B3-U0-G5
<b>RW</b>	4000K/5000K Lumens	4,293	8,390	12,520	16,542	20,496	24,527	29,007	32,866	36,662	40,591
	3000K Lumens	4,059	7,932	11,837	15,640	19,378	23,189	27,425	31,074	34,662	38,377
	BUG Rating	B2-U0-G1	B3-U0-G1	B3-U0-G2	B4-U0-G2	B4-U0-G2	B4-U0-G2	B4-U0-G2	B5-U0-G3	B5-U0-G3	B5-U0-G3
<b>AFL</b>	4000K/5000K Lumens	4,310	8,421	12,566	16,602	20,571	24,616	29,112	32,986	36,795	40,738
	3000K Lumens	4,074	7,962	11,881	15,697	19,448	23,273	27,525	31,187	34,788	38,516
	BUG Rating	B1-U0-G1	B1-U0-G1	B2-U0-G2	B2-U0-G2	B2-U0-G2	B3-U0-G2	B3-U0-G3	B3-U0-G3	B3-U0-G3	B3-U0-G3

\* Nominal data for 70 CRI.



**CONTROL OPTIONS**

**0-10V (DIM)**

This fixture is offered standard with 0-10V dimming driver(s). The DIM option provides 0-10V dimming wire leads for use with a lighting control panel or other control method.

**Photocontrol (P, R and PER7)**

Optional button-type photocontrol (P) and photocontrol receptacles (R and PER7) provide a flexible solution to enable "dusk-to-dawn" lighting by sensing light levels. Advanced control systems compatible with NEMA 7-pin standards can be utilized with the PER7 receptacle.

**After Hours Dim (AHD)**

This feature allows photocontrol-enabled luminaires to achieve additional energy savings by dimming during scheduled portions of the night. The dimming profile will automatically take effect after a "dusk-to-dawn" period has been calculated from the photocontrol input. Specify the desired dimming profile for a simple, factory-shipped dimming solution requiring no external control wiring. Reference the After Hours Dim supplemental guide for additional information.

**Dimming Occupancy Sensor (MS/DIM-LXX, MS/X-LXX and MS-LXX)**

These sensors are factory installed in the luminaire housing. When the MS/DIM-LXX sensor option is selected, the occupancy sensor is connected to a dimming driver and the entire luminaire dims when there is no activity detected. When activity is detected, the luminaire returns to full light output. The MS/DIM sensor is factory preset to dim down to approximately 50 percent power with a time delay of five minutes. The MS-LXX sensor is factory preset to turn the luminaire off after five minutes of no activity. The MS/X-LXX is also preset for five minutes and only controls the specified number of light engines to maintain steady output from the remaining light engines.

These occupancy sensors includes an integral photocell that can be activated with the FSIR-100 accessory for "dusk-to-dawn" control or daylight harvesting - the factory preset is OFF. The FSIR-100 is a wireless tool utilized for changing the dimming level, time delay, sensitivity and other parameters. A variety of sensor lens are available to optimize the coverage pattern for mounting heights from 8'-40'.

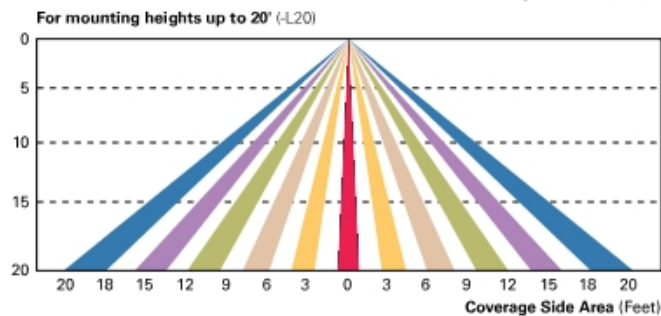
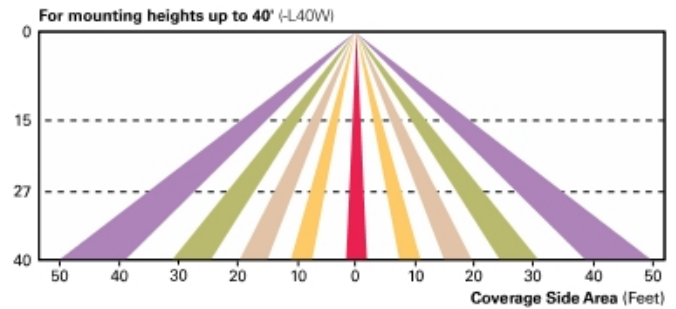
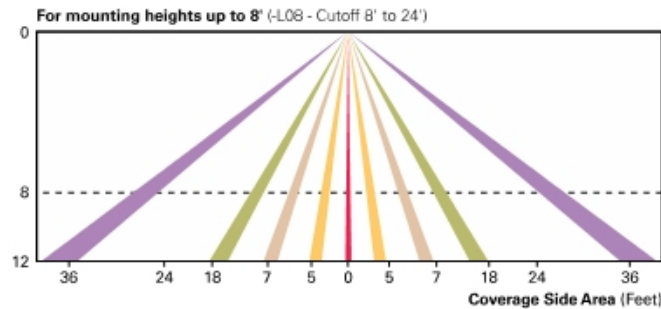

**LumaWatt Pro Wireless Control and Monitoring System (LWR-LW and LWR-LN)**

The Eaton's LumaWatt Pro powered by Enlighted is a connected lighting solution that combines a broad selection of energy-efficient LED luminaires with a powerful integrated wireless sensor system. The sensor controls the lighting system in compliance with the latest energy codes and collects valuable data about building performance and use. Software applications turn the granular data into information through energy dashboards and specialized apps that make it simple and help optimize the use of building resources, beyond lighting.

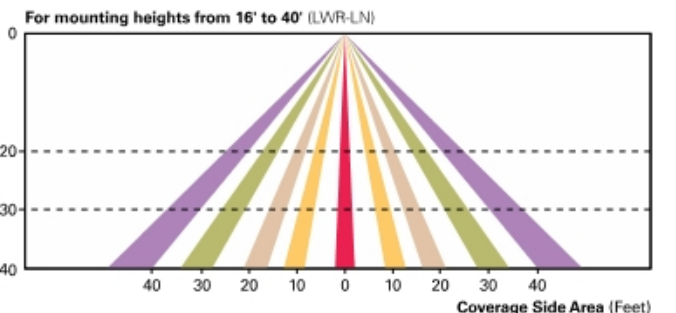
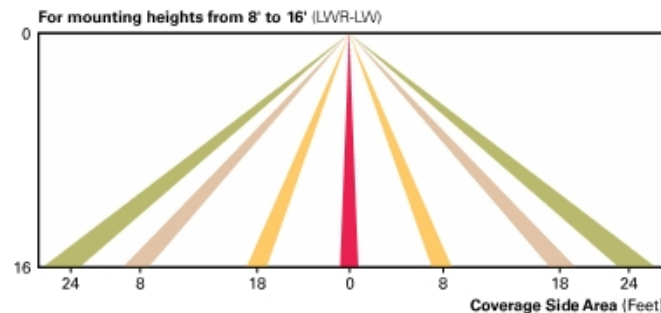

**WaveLinx Wireless Outdoor Lighting Control Module (WOLC-7P-10A)**

The 7-pin wireless outdoor lighting control module enables WaveLinx to control outdoor area, site and flood lighting. WaveLinx controls outdoor lighting using schedules to provide ON, OFF and dimming controls based on astronomical or time schedules based on a 7 day week.

**LumenSafe Integrated Network Security Camera (LD)**

Eaton brings ease of camera deployment to a whole new level. No additional wiring is needed beyond providing line power to the luminaire. A variety of networking options allows security integrators to design the optimal solution for active surveillance. As the ideal solution to meet the needs for active surveillance, the LumenSafe integrated network camera is a streamlined, outdoor-ready fixed dome that provides HDTV 1080p video. This IP camera is optimally designed for deployment in the video management system or security software platform of choice.

**Synapse (DIM10)**

SimplySNAP integrated wireless controls system by Synapse. Includes factory installed DIM10 Synapse control module and MS/DC motion sensor; requires additional Synapse system components for operation. Contact Synapse at [www.synapsewireless.com](http://www.synapsewireless.com) for product support, warranty and terms and conditions.

**ORDERING INFORMATION**

Sample Number: GLEON-AF-04-LED-E1-T3-GM-QM

Product Family <sup>1,2</sup>	Light Engine	Number of Light Squares <sup>3</sup>	Lamp Type	Voltage	Distribution	Color	Mounting		
GLEON=Galleon	AF=1A Drive Current	01=1 02=2 03=3 04=4 05=5 <sup>4</sup> 06=6 07=7 <sup>5</sup> 08=8 <sup>5</sup> 09=9 <sup>5</sup> 10=10 <sup>6</sup>	LED=Solid State Light Emitting Diodes	E1=120-277V 347=347V <sup>7</sup> 480=480V <sup>18</sup>	T2=Type II T2R=Type II Roadway T3=Type III T3R=Type III Roadway T4FT=Type IV Forward Throw T4W=Type IV Wide 5NQ=Type V Narrow 5MQ=Type V Square Medium 5WQ=Type V Square Wide SL2=Type II w/Spill Control SL3=Type III w/Spill Control SL4=Type IV w/Spill Control SLL=90° Spill Light Eliminator Left SLR=90° Spill Light Eliminator Right RW=Rectangular Wide Type I AFL=Automotive Frontline	AP=Grey BZ=Bronze BK=Black DP=Dark Platinum GM=Graphite Metallic WH=White	[Blank]=Arm for Round or Square Pole EA=Extended Arm <sup>9</sup> MA=Mast Arm Adapter <sup>10</sup> WM=Wall Mount QM=Quick Mount Arm (Standard Length) <sup>11</sup> QMEA=Quick Mount Arm (Extended Length) <sup>12</sup>		
<b>Options (Add as Suffix)</b>						<b>Accessories (Order Separately)</b>			
<p>7027=70 CRI 2700K<sup>13</sup> 7030=70 CRI 3000K<sup>13</sup> 8030=80 CRI 3000K<sup>13</sup> 7050=70 CRI 5000K<sup>13</sup> 7060=70 CRI 6000K<sup>13</sup> 600=Drive Current Set to Nominal 600mA<sup>19</sup> 800=Drive Current Set to Nominal 800mA<sup>19</sup> 1200=Drive Current Set to Nominal 1200mA<sup>19,20</sup> F=Single Fuse (120, 277 or 347V. Specify Voltage) FF=Double Fuse (208, 240 or 480V. Specify Voltage) 2L=Two Circuits<sup>13,18</sup> DIM=External 0-10V Dimming Leads<sup>18,20</sup> DIM10=Synapse Integrated Control Module<sup>14,19</sup> AHD145=After Hours Dim, 5 Hours<sup>22</sup> AHD245=After Hours Dim, 6 Hours<sup>22</sup> AHD255=After Hours Dim, 7 Hours<sup>22</sup> AHD355=After Hours Dim, 8 Hours<sup>22</sup> HA=50°C High Ambient<sup>23</sup> L90=Optics Rotated 90° Left R90=Optics Rotated 90° Right MT=Installed Mesh Top TH=Tool-Less Door Hardware HSS=Installed House Side Shield<sup>26</sup> CE=CE Marking<sup>29</sup> LCF=Light Square Trim Painted to Match Housing<sup>27</sup></p>						<p>P=ButtonType Photocontrol (120, 208, 240 or 277V. Must Specify Voltage)<sup>21</sup> PER7=NEMA 7-PIN Photocontrol Receptacle<sup>21</sup> R=NEMA Photocontrol Receptacle<sup>21</sup> MS-L08=Motion Sensor for ON/OFF Operation, Maximum 8' Mounting Height<sup>24</sup> MS-L20=Motion Sensor for ON/OFF Operation, 9' - 20' Mounting Height<sup>24</sup> MS-L40W=Motion Sensor for ON/OFF Operation, 21' - 40' Mounting Height<sup>24</sup> MS/DIM-L08=Motion Sensor for Dimming Operation, Maximum 8' Mounting Height<sup>24</sup> MS/DIM-L20=Motion Sensor for Dimming Operation, 9' - 20' Mounting Height<sup>24</sup> MS/DIM-L40W=Motion Sensor for Dimming Operation, 21' - 40' Mounting Height<sup>24</sup> MS/X-L08=Bi-Level Motion Sensor, Maximum 8' Mounting Height<sup>24,25</sup> MS/X-L20=Bi-Level Motion Sensor, 9' - 20' Mounting Height<sup>24,25</sup> MS/X-L40W=Bi-Level Motion Sensor, 21' - 40' Mounting Height<sup>24,25</sup> LWR-LW=LumaWatt Pro Wireless Sensor, Wide Lens for 8' - 16' Mounting Height<sup>26</sup> LWR-LN=LumaWatt Pro Wireless Sensor, Narrow Lens for 16' - 40' Mounting Height<sup>26</sup> ZW=WaveLinx-enabled 4-PIN Twistlock Receptacle<sup>19,33</sup> ZW-SWPD4XX=WaveLinx Wireless Sensor, 7' - 15' Mounting Height<sup>19,33,34</sup> ZW-SWPD5XX=WaveLinx Wireless Sensor, 15' - 40' Mounting Height<sup>19,33,34</sup></p>		<p>OA/RA1016=NEMA Photocontrol Multi-Tap - 105-285V OA/RA1027=NEMA Photocontrol - 480V OA/RA1201=NEMA Photocontrol - 347V OA/RA1013=Photocontrol Shorting Cap OA/RA1014=120V Photocontrol MA1252=10kV Surge Module Replacement MA1036-XX=Single Tenon Adapter for 2-3/8" O.D. Tenon MA1037-XX=2@180° Tenon Adapter for 2-3/8" O.D. Tenon MA1197-XX=3@120° Tenon Adapter for 2-3/8" O.D. Tenon MA1188-XX=4@90° Tenon Adapter for 2-3/8" O.D. Tenon MA1189-XX=2@90° Tenon Adapter for 2-3/8" O.D. Tenon MA1190-XX=3@90° Tenon Adapter for 2-3/8" O.D. Tenon MA1191-XX=2@120° Tenon Adapter for 2-3/8" O.D. Tenon MA1038-XX=Single Tenon Adapter for 3-1/2" O.D. Tenon MA1039-XX=2@180° Tenon Adapter for 3-1/2" O.D. Tenon MA1192-XX=3@120° Tenon Adapter for 3-1/2" O.D. Tenon MA1193-XX=4@90° Tenon Adapter for 3-1/2" O.D. Tenon MA1194-XX=2@90° Tenon Adapter for 3-1/2" O.D. Tenon MA1195-XX=3@90° Tenon Adapter for 3-1/2" O.D. Tenon FSIR-100=Wireless Configuration Tool for Occupancy Sensor<sup>34</sup> GLEON-MT1=Field Installed Mesh Top for 1-4 Light Squares GLEON-MT2=Field Installed Mesh Top for 5-6 Light Squares GLEON-MT3=Field Installed Mesh Top for 7-8 Light Squares GLEON-MT4=Field Installed Mesh Top for 9-10 Light Squares GLEON-QM=Quick Mount Arm Kit<sup>11</sup> GLEON-QMEA=Quick Mount Extended Arm Kit<sup>12</sup> LS/HSS=Field Installed House Side Shield<sup>28,30</sup> WOLC-7P-10A=WaveLinx Outdoor Control Module<sup>19,31</sup> SWPD4-XX=WaveLinx Wireless Sensor, 7' - 15' Mounting Height<sup>19,32,33,34</sup> SWPD5-XX=WaveLinx Wireless Sensor, 15' - 40' Mounting Height<sup>19,32,33,34</sup></p>	

**NOTES:**  
 1 Customer is responsible for engineering analysis to confirm pole and fixture compatibility for all applications. Refer to our white paper WP513001EN for additional support information. 2 DesignLights Consortium<sup>™</sup> Qualified. Refer to www.designlights.org Qualified Products List under Family Models for details. 3 Standard 4000K CCT and minimum 70 CRI. 4 Not compatible with MS/4-LXX or MS/1-LXX sensors. 5 Not compatible with extended quick mount arm (QMEA). 6 Not compatible with standard quick mount arm (QM) or extended quick mount arm (QMEA). 7 Requires the use of an internal step down transformer when combined with sensor options. Not available with sensor at 1200mA. Not available in combination with the HA high ambient and sensor options at 1A. 8 Only for use with 480V Wye systems. Per NEC, not for use with ungrounded systems, impedance grounded systems or corner grounded systems (commonly known as Three Phase Three Wire Delta, Three Phase High Leg Delta and Three Phase Corner Grounded Delta systems). 9 May be required when two or more luminaires are oriented on a 90° or 120° drilling pattern. Refer to arm mounting requirement table. 10 Factory installed. 11 Maximum 8 light squares. 12 Maximum 6 light squares. 13 Extended lead times apply. Use dedicated IES files for 2700K, 3000K, 5000K and 6000K when performing layouts. 14 Available in 800mA only. 15 1 Amp standard. Use dedicated IES files for 600mA, 800mA and 1200mA when performing layouts. 16 Not available with HA option. 17 2L is not available with MS, MS/X or MS/DIM at 347V or 480V. 2L in AF-02 through AF-04 requires a larger housing, normally used for AF-05 or AF-06. Extended arm option may be required when mounting two or more fixtures per pole at 90° or 120°. Refer to arm mounting requirement table. 18 Not available with LumaWatt Pro wireless sensors. 19 Cannot be used with other control options. 20 Low voltage control lead brought out 18" outside fixture. 21 Not available if any "MS" sensor is selected. Motion sensor has an integral photocell. 22 Requires the use of P photocontrol or the PER7 or R photocontrol receptacle with photocontrol accessory. See After Hours Dim supplemental guide for additional information. 23 50°C lumen maintenance data applies to 600mA, 800mA and 1A drive currents. 24 The FSIR-100 configuration tool is required to adjust parameters including high and low modes, sensitivity, time delay, cutoff and more. Consult your lighting representative at Eaton for more information. 25 Replace X with number of Light Squares operating in low output mode. 26 LumaWatt Pro wireless sensors are factory installed only requiring network components LWP-EM-1, LWP-GW-1 and LWP-PoE8 in appropriate quantities. See www.eaton.com/lighting for LumaWatt Pro application information. 27 Not available with house side shield (HSS). 28 Only for use with SL2, SL3, SL4 and AFL distributions. The Light Square trim plate is painted black when the HSS option is selected. 29 CE is not available with the LWR, MS, MS/X, MS/DIM, P, R or PER7 options. Available in 120-277V only. 30 One required for each Light Square. 31 Requires PER7. 32 Requires ZW. 33 WAC Gateway required to enable field-configurability: Order WAC-PoE and WPOE-120 (10V to PoE injector) power supply if needed. 34 Replace XX with sensor color (WH, BZ, or BK).

**LumenSafe Integrated Network Security Camera Technology Options (Add as Suffix)**

Product Family	Camera Type	Data Backhaul	
L=LumenSafe Technology <sup>*</sup> 	D=Dome Camera, Standard H=Dome Camera, HI-Res Z=Dome Camera, Remote PTZ	C=Cellular, Customer Installed SIM Card A=Cellular, Factory Installed AT&T SIM Card V=Cellular, Factory Installed Verizon SIM Card S=Cellular, Factory Installed Sprint SIM Card	W=Wi-Fi Networking w/ Omni-Directional Antenna E=Ethernet Networking

\*Consult LumenSafe system pages for additional details and compatibility.





NT

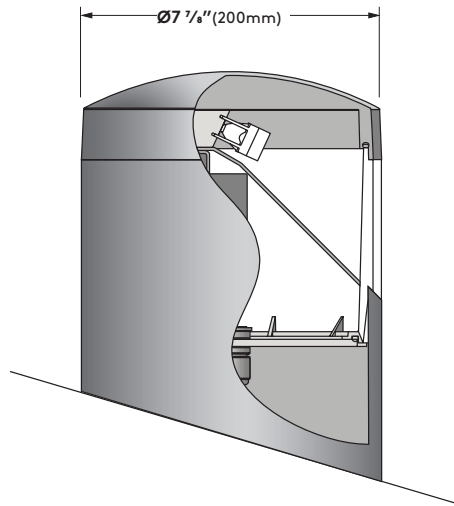

## Specifications

**Fixture Housing** - Made from die cast, low copper aluminum alloy.

**Gasketing** - Continuous molded silicone gasket provides weatherproofing, dust and insect control at shielding base, and fixture cover.

**Shielding** - Transparent, continuous one-piece injection molded, UV stabilized polycarbonate lens, minimum wall thickness  $\frac{5}{16}$ " (8.25mm). Shielding is flush with column surface completely enclosing optic chamber.

**LED Array** - LEDs mounted to metal core PC boards and directly attached to aluminum heat sink for maximum LED performance and life. Includes LED drivers and precise high performance injection-molded lenses. Complete light engine can be easily replaced. LEDs can be started and re-started instantly at temperatures as low as  $-20^{\circ}$ . For lumen maintenance information, see IESTM-21-11 details.

**LED Optics** - High precision injection molded lenses consisting of Total Internal Reflection (TIR) collimator and light shaping lens. Lenses produce an asymmetric distribution.

**Column** - Extruded thick-walled low copper aluminum, minimum wall thickness 0.118" (3mm) with internal anchor bolts and flush handhole cover.

**Surge Protection** - Designed to protect luminaire from electrical surge (up to 10kA).

**Exterior Luminaire Finish** - Selux utilizes a high quality Polyester Powder Coating. All Selux luminaires and poles are finished in our Tiger Drylac certified facility and undergo a five stage intensive pretreatment process where product is thoroughly cleaned, phosphated and sealed. Selux powder coated products provide excellent salt and humidity resistance as well as ultra violet resistance for color retention. All products are tested in accordance with test specifications for coatings from ASTM and PCI.

Standard exterior colors are White (WH), Black (BK), Semi-Matte Black (BL), Bronze (BZ), and Silver (SV). Selux premium colors (SP) are available, please specify from your Selux color selection guide.

### 5 Year Limited LED Luminaire Warranty

Selux offers a 5 Year Limited Warranty to the original purchaser that the Selux LED luminaire shall be free from defects in material and workmanship for up to five (5) years from date of shipment. This limited warranty covers the fixture, LED driver and LED light engine when installed and operated according to Selux instructions. Fixture suitable for ambient temperatures of  $40^{\circ}$  C ( $104^{\circ}$  F). For details and exclusions, see "Selux Terms and Condition of Sale."

Listings and Ratings: Tested to IESNA LM-79-08 and LM-80 test standards at  $25^{\circ}$  C ambient temperature.

**Visit [selux.us](http://selux.us) for our LED End of Life recycling policy.**



Wiring Diagrams

**Standard Single Wiring**

LG4700 at 120-277V for high output.  
 LG4500 at 120-277V for low output.

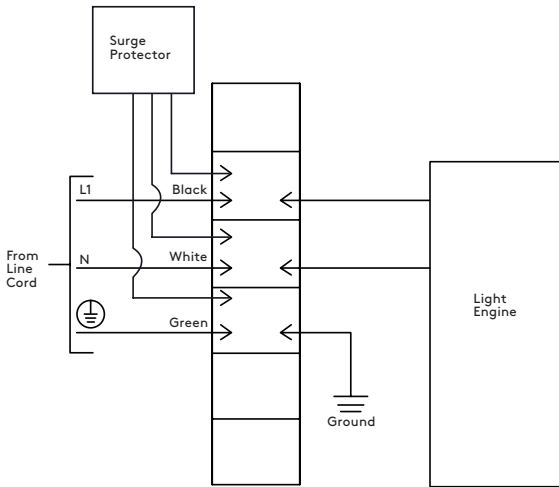

**0-10V Dimming Option (DM) Wiring**

LG4700 at 120-277V.

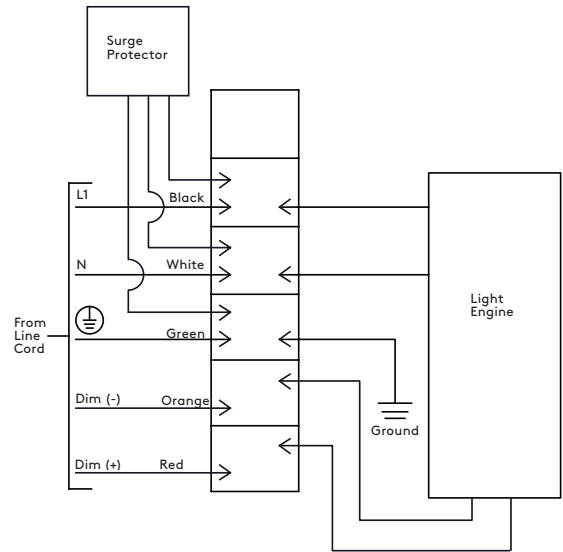

**Hi-Lo Switching Option (HL) Wiring**

LG4700 at 120-277V. When red is energized, power consumption will be at "Lo" level. Lo = 70% power consumption.

**347/480V**

LG4700 at 347/480V for high output. LG4500 at 347/480V for low output.

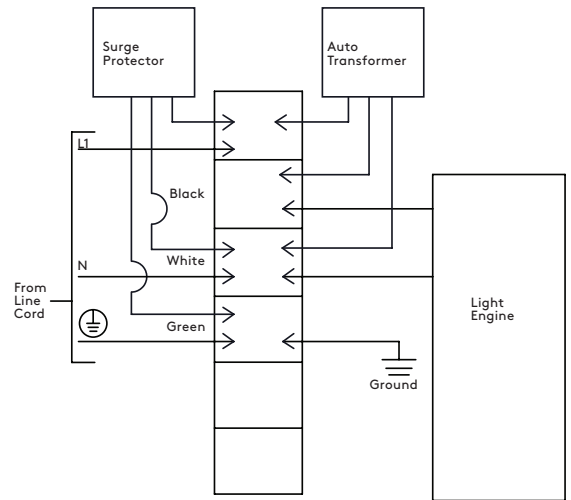
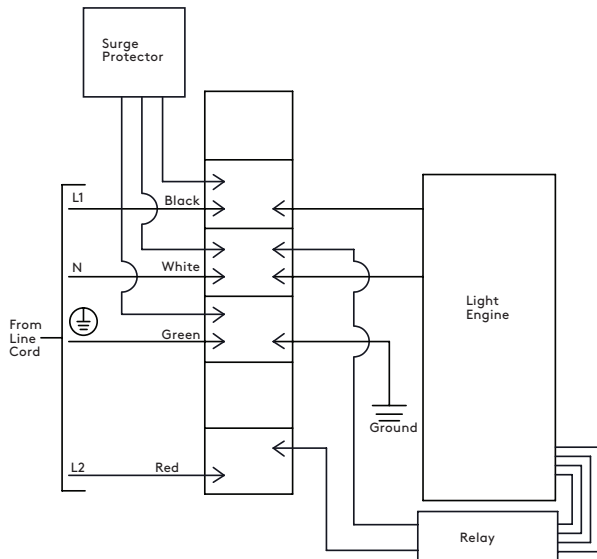

Mounting Details

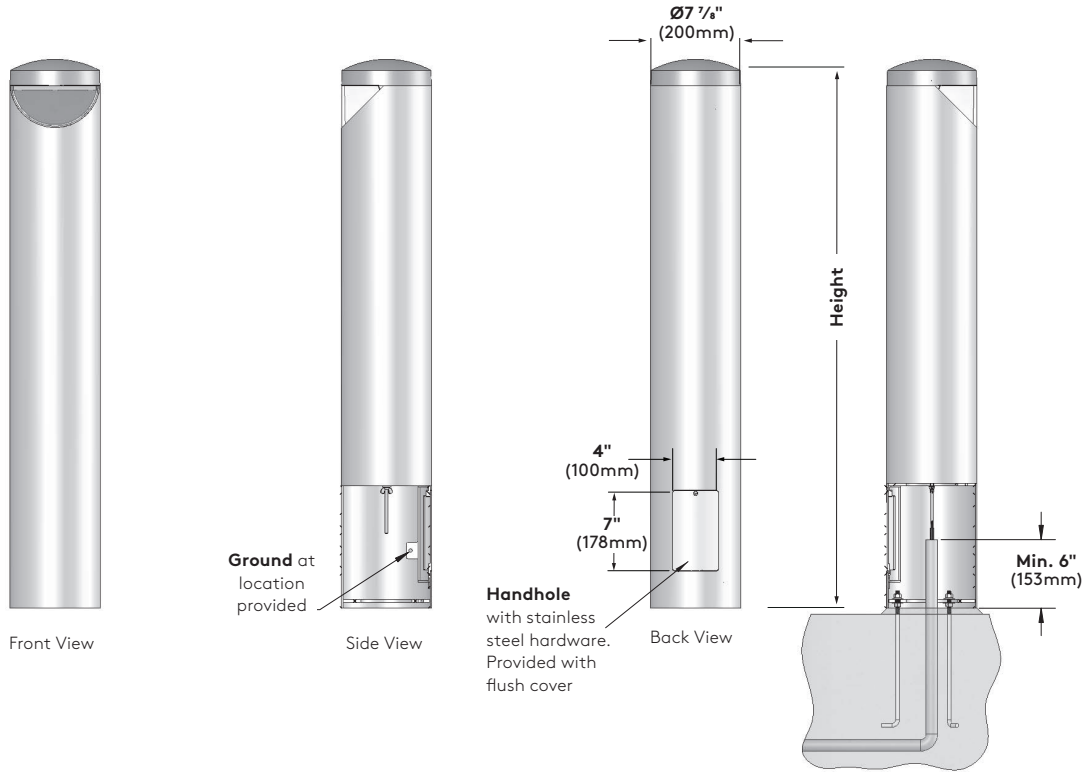

Anchorage Details

**NOTES:**

1. BOLLARD ORIENTATION IS CRITICAL, ROD & HAND HOLE LOCATIONS ARE CRITICAL.
2. LOCATE SINGLE BOLT AT HAND HOLE LOCATION.
3. ADEQUATE DRAINAGE MUST BE PROVIDED IN CONCRETE FOUNDATION.
4. CONDUIT SHOULD BE STUBBED UP ABOVE THE CONCRETE FOOTING

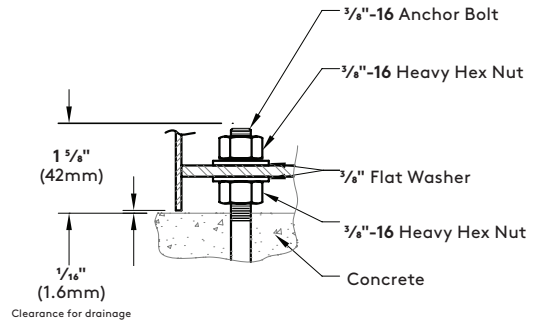
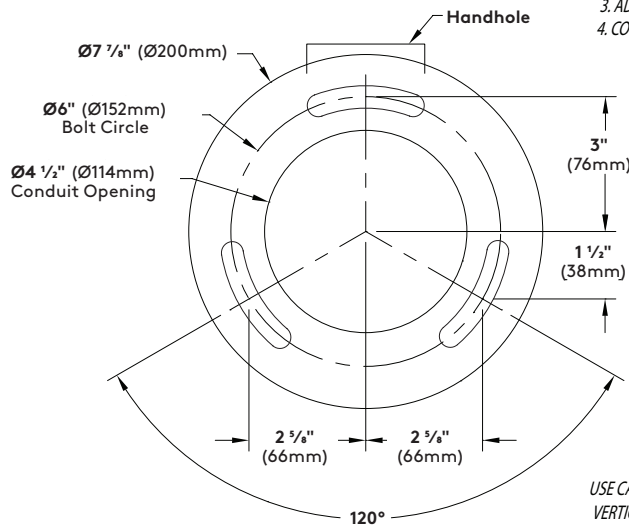

**BOLT CIRCLE DETAIL (Not to Scale)**

USE CAUTION WHEN SETTING ANCHOR BOLTS. BOLTS MUST BE VERTICALLY STRAIGHT AND CENTERED ON DIMENSIONS SHOWN.



**Optional Accessories**

**GFCI Receptacle (REC)** - 120V 15A GFCI duplex receptacle with weather-proof, self-closing, non-lockable cover; located 36" (915mm) from base of pole, inline with handhole. Receptacle is intended only for portable tools or other portable equipment to be connected to outlet only when attended by operating personnel. For use with 120V applications only. For use with luminaires with other than 120V rating, please consult factory for wire segregation.

**GFCI Receptacle (REC2)** - 120V 15A GFCI duplex receptacle with weather-proof, self-closing, padlockable in-use cover; located 36" (915mm) from base of pole, inline with handhole. Receptacle is intended only for portable tools or other portable equipment to be connected to outlet only when attended by operating personnel. For use with 120V applications only. For use with luminaires with other than 120V rating, please consult factory for wire segregation.

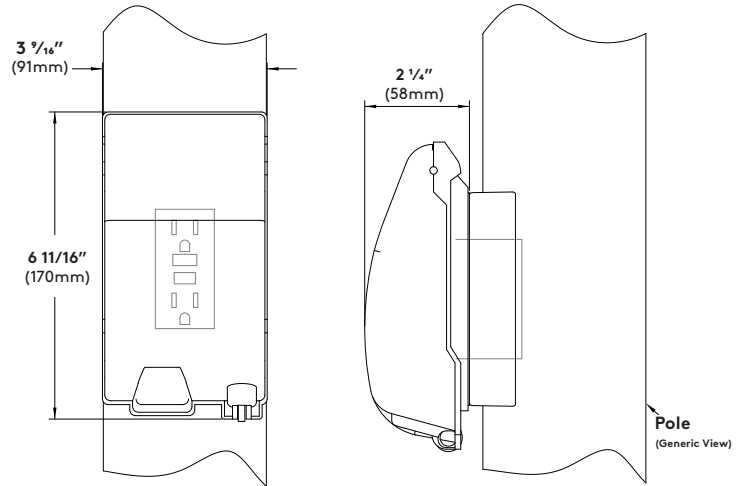
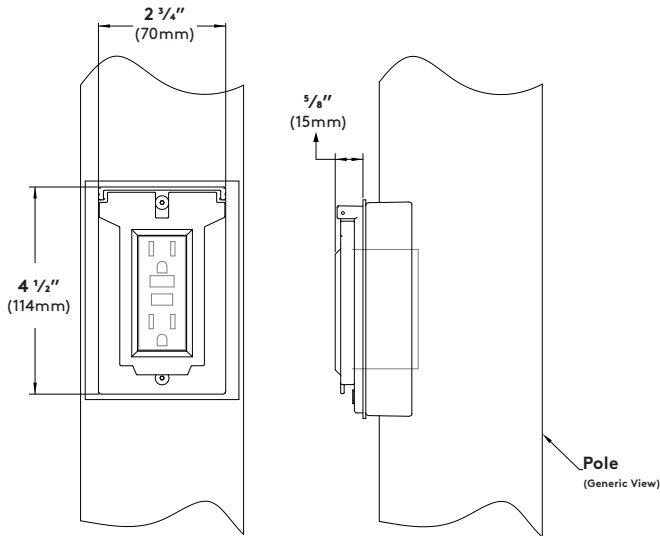

# Notch Bollard LED



## Photometry

### 14W LED / 3000K CCT

Catalog #: NT-4-LG4700-30  
 Report #: 830336  
 Delivered Lumens: 676  
 Input Watts: 14W  
 Efficacy: 47  
 CCT: 3000K  
 Maximum candela of 856 at 65° from vertical.  
 Mounting Height: 4' (1.22 M)  
 BUG Rating: B0-U1-G1

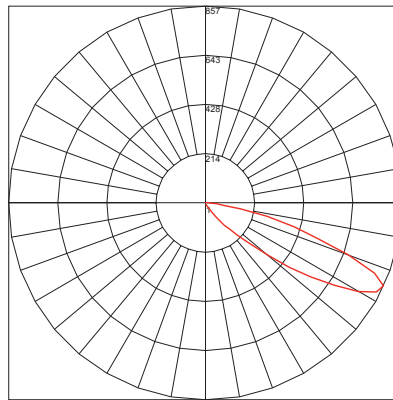

Maximum Candela = 856.8 Located At Horizontal Angle = 25, Vertical Angle = 65  
 # 1 - Vertical Plane Through Horizontal Angles (25 - 205) (Through Max. Cd.)

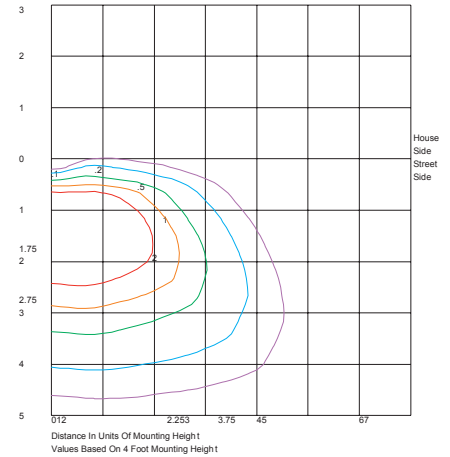

Distance In Units Of Mounting Height  
 Values Based On 4 Foot Mounting Height

### 14W LED / 3500K CCT

Catalog #: NT-4-LG4700-35  
 Report #: 830336\_35  
 Delivered Lumens: 834  
 Input Watts: 14W  
 Efficacy: 58  
 CCT: 3500K  
 Maximum candela of 856 at 65° from vertical.  
 Mounting Height: 4' (1.22 M)  
 BUG Rating: B0-U1-G1

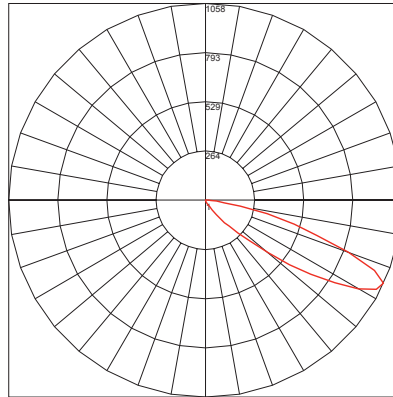

Maximum Candela = 1057.72 Located At Horizontal Angle = 25, Vertical Angle = 65  
 # 1 - Vertical Plane Through Horizontal Angles (25 - 205) (Through Max. Cd.)

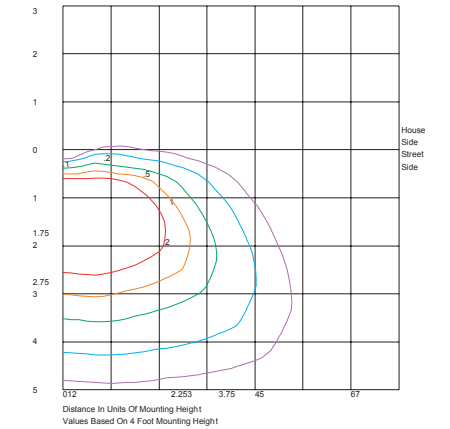

Distance In Units Of Mounting Height  
 Values Based On 4 Foot Mounting Height

### 14W LED / 4000K CCT

Catalog #: NT-4-LG4700-40  
 Report #: 830336\_40  
 Delivered Lumens: 804  
 Input Watts: 14W  
 Efficacy: 56  
 CCT: 4000K  
 Maximum candela of 1019 at 65° from vertical.  
 Mounting Height: 4' (1.22 M)  
 BUG Rating: B0-U1-G1

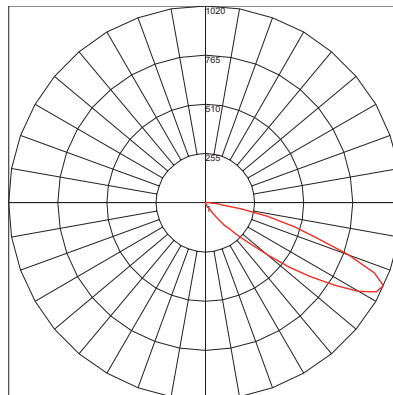

Maximum Candela = 1019.678 Located At Horizontal Angle = 25, Vertical Angle = 65  
 # 1 - Vertical Plane Through Horizontal Angles (25 - 205) (Through Max. Cd.)

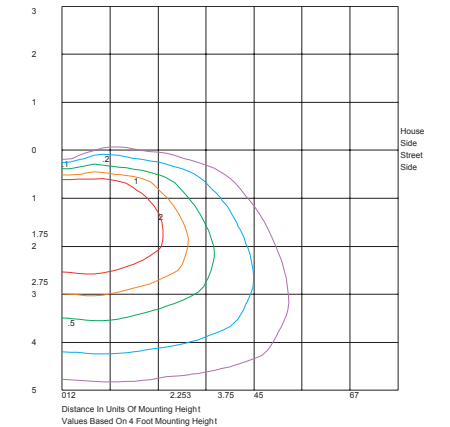

Distance In Units Of Mounting Height  
 Values Based On 4 Foot Mounting Height



**Photometry**

14W LED / 5000K CCT

Catalog #: NT-4-LG4700-50

Report #: 830336\_50

Delivered Lumens: 935

Input Watts: 14W

Efficacy: 65

CCT: 5000K

Maximum candela of 1186 at 65° from vertical.

Mounting Height: 4' (1.22 M)

BUG Rating: B0-U1-G1

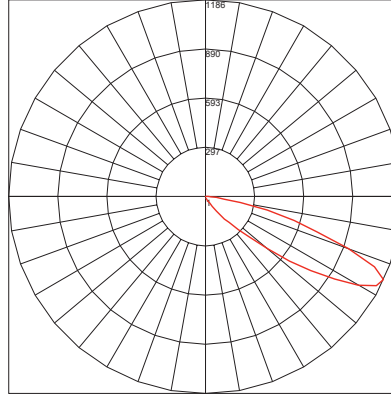

Maximum Candela = 1186.411 Located At Horizontal Angle = 25, Vertical Angle = 65  
# 1 - Vertical Plane Through Horizontal Angles (25 - 205) (Through Max. Cd.)

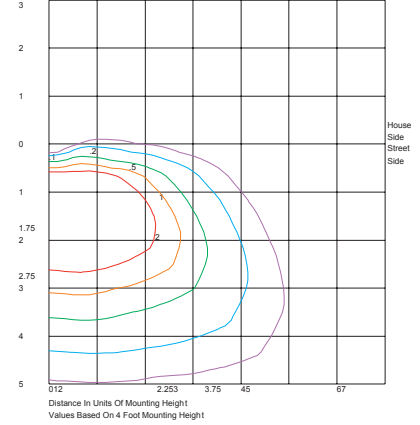

Distance In Units Of Mounting Height  
Values Based On 4 Foot Mounting Height

**Conversion Chart**

Values based on 3' (.9) mounting height

Mounting Height	Multiply
2.0' (.6 m)	1.22
2.5' (.8 m)	1.09
3.0' (.9 m)	1.00
3.5' (1.1 m)	0.92
4.0' (1.2 m)	0.87

**IES TM-21-11 Report Results**

Based on an ambient temperature of 25°C / 77° F

Reported L70 (6k) (hours) > 36,000

Calculated L70 (6k) (hours) > 601,000

25,000h lumen maintenance predicted to be 98.75%

**Notch Bollard LED GEN 4 Lumen Matrix**

Model#	Watts	Scale Factor from BASE	Delivered Lumens	NT Toolbox Scale Factor	Lumens/Watt	Light Engine Multiplier	CCT Multiplier
NT-X-LG4500-30-120	10.42	1.0000	405	1.0000	38.9	1.000	<b>3000K CCT = 1.000</b>
NT-X-LG4700-30-120	14.39	1.0000	676	1.0000	47.0	1.669	
NT-X-LG4500-35-120	10.42	1.2345	500	1.2345	48.0	1.000	<b>3500K CCT = 1.235</b>
NT-X-LG4700-35-120	14.39	1.2345	835	1.2345	58.0	1.669	
NT-X-LG4500-40-120	10.42	1.1901	482	1.1901	46.3	1.000	<b>4000K CCT = 1.190</b>
NT-X-LG4700-40-120	14.39	1.1901	805	1.1901	55.9	1.669	
NT-X-LG4500-50-120	10.42	1.3847	561	1.3847	53.8	1.000	<b>5000K CCT = 1.385</b>
NT-X-LG4700-50-120	14.39	1.3847	936	1.3847	65.1	1.669	