



# VIII.B

---

690 Chesterfield Pkwy W • Chesterfield MO 63017-0760  
Phone: 636-537-4000 • Fax 636-537-4798 • [www.chesterfield.mo.us](http://www.chesterfield.mo.us)

---

## Planning Commission Vote Report

**Subject:** Change of Zoning Vote Report

**Meeting Date:** April 27, 2015

**From:** Purvi Patel, Project Planner

**Location:** West side of Wilson Avenue south of its intersection with Chamfers Farm Road and north of its intersection with Wilson Farm Drive

**Petition:** **P.Z. 02-2015 Falling Leaves Estates II (1925 & 1921 Wilson Ave)**

### Summary

Fischer & Frichtel Inc. has submitted a request for a zoning map amendment to rezone 17.37 acres for a proposed single-family residential development. The tract is currently zoned “R-1” Residential District and the requested amendment is for a change of zoning to a “PUD” Planned Unit Development. As required for a “PUD” Planned Unit Development, a Preliminary Plan and Project Narrative are included for your review.

This petition was before the Planning Commission on April 13<sup>th</sup>, 2015, to follow up on issues identified during the March 9<sup>th</sup>, 2015 Public Hearing and to examine if any further issues needed to be resolved prior to requesting a recommendation on this petition from the Planning Commission. At this meeting, the Planning Commission identified 3 additional issues associated with this “PUD” request. The petitioner has submitted a written response and updated Preliminary Plan to address those issues and these are included in the Planning Commission packet.

The “PUD” request is for a total of 16 lots which range in size from 22,000 square feet to 27,205 square feet with an average lot size of 24,232 square feet. Additional development characteristics proposed include 38% Common Open Space, 30 foot perimeter buffers, enhanced entrance with landscaping on either side of the private drive, as well as sidewalks within the development and along Wilson Avenue. Furthermore, the site is designed to take advantage of an existing lake on site.

### Site History

The existing subject site includes two parcels of 12.37 and 5.00 acres in size and was originally zoned “R-1” Residence District by St. Louis County prior to the incorporation of the City of Chesterfield. In 1977, a petition was filed with St. Louis County to rezone 188.16 acres from “NU” Non-Urban District to “R-1” One-Acre Residence District (P.C 80-1977); at the same time, a second petition was filed to request a “PEU” Planned Environmental Unit in an “R-1” One-Acre Residence District for the same 188.16 acres (P.C. 81-1977). During the St. Louis County Planning Commission Vote meeting for these petitions, approximately 40 acres nearest to Wilson Avenue were removed from the PEU portion of the request. The two tracts of the current subject site were part of that 40 acres and are zoned “R-1” Residence District today.

**Surrounding Land Use and Zoning**

- North:** North of the site are two single-family dwellings zoned “R-1” Residence District. One of these homes is the current residence of the Petitioner.
- South:** The property to the south is the Wilson Farm Estates Subdivision and is zoned “R-1” Residence District with a “PEU” Planned Environmental Unit.
- East:** The properties to the east are the Bent Tree and Chesterfield Meadows Subdivisions. The Bent Tree Subdivision is zoned “R-1”, “R-1A” and “R-2” Residence Districts with a “PEU” Planned Environmental Unit; and Chesterfield Meadows Subdivision includes both “R-1” and “R-1A” Residence Districts and is a Density Development.
- West:** The Wilson Farm Estates Subdivision wraps to the west of the subject site as well.



**Figure 1 – Aerial**

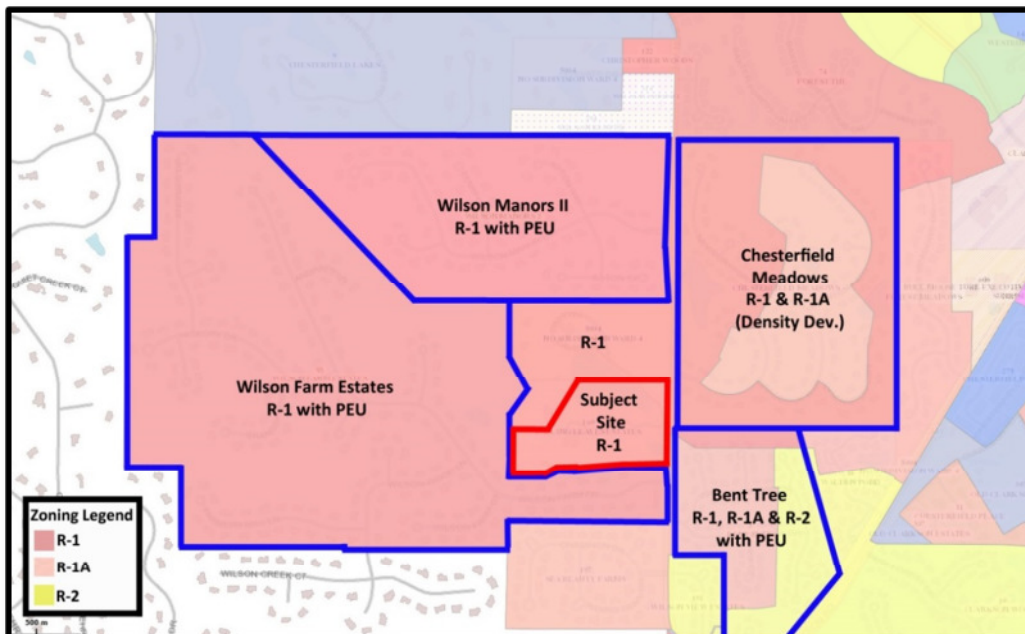

**Figure 2 – Adjacent Subdivisions & Zoning**

### **Comprehensive Plan Analysis**

The subject site is located within Ward 4 of the City of Chesterfield. The City of Chesterfield Land Use Plan indicates these parcels are within the Residential Single-Family District. Proposed uses and density of the “PUD” (1 unit per acre) would be compliant with the Land Use Plan. This subject site is not located in any sub-area identified by the Comprehensive Plan.

Furthermore, the Comprehensive Plan lists Residential Development Policies which include items listed below as they apply to this development:

- **2.1.6 Reinforce Existing Residential Development Pattern** - New residential development should reinforce existing residential neighborhood patterns by continuing to enforce high quality site and subdivision design, layout, and planning practices.
  - *Please see Existing Conditions section on Page 5 for more details on this this development is compatible with adjacent developments.*
- **2.1.9 Encourage Planned Residential Development** - Planned residential developments that allow for innovative and flexible site planning, preservation of open space, and a variety of housing opportunities should be encouraged.
  - *This policy is met through the “PUD” requirements of the City of Chesterfield Code.*
- **2.1.11 Restrict Access of Individual Homes on Arterial Streets** - Prevent the platting of new residential subdivisions in which lots have direct access to abutting arterial streets.
  - *It is important to note that even though Wilson Avenue is considered a collector street, the Petitioner is not proposing any lots with direct access to Wilson Avenue and is only proposing one entrance onto Wilson Avenue for the entire development.*

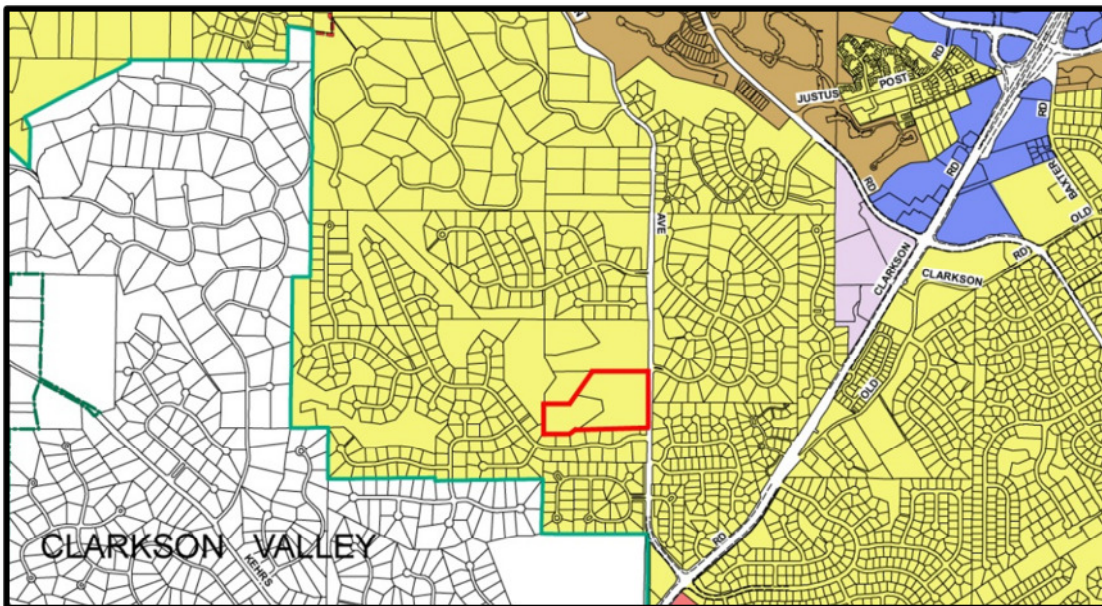

**Figure 3 – Comprehensive Land Use Plan**

## **Analysis**

### **“PUD” Procedure**

As discussed in Staff’s Issues Report (April 13<sup>th</sup>, 2015), the following section addresses the “PUD” procedure as listed in the City of Chesterfield Municipal Code:

The project has met 3 General Requirements in order to fulfill the application requirements for a “PUD”. These 3 items are required for the application to pass sufficiency review and are as follows:

- The property is at least 4 contiguous acres.
- The property is under single ownership, or if under multiple ownership then written consent of owners is required.
- Acknowledgement that satisfying the minimum standards of the “PUD” District does not per se indicate that an application is entitled to a zoning change and that the City of Chesterfield may impose conditions and safeguards in excess of, or in addition to, the specified minimal requirements.

Once the application has passed sufficiency review, it is reviewed against the Minimum Design Requirements for a “PUD”. There are 4 minimum design requirements that must be met in order for the project to qualify for a “PUD” and once these were met, the petition was scheduled for Public Hearing. These 4 items are:

- Proposal has to meet the maximum residential density determined by the existing zoning district or by submitting an application for a change of zoning from the "NU" Non-Urban District to a residential zoning district.
- Provision of 30 percent Common Open Space to be displaced throughout the site and not concentrated in one area or contain only that portion of the site that would be considered undevelopable.
- Provision of perimeter buffer of at least 30 feet in width.
- Proposed project has to be consistent with the purposes and intent of the Comprehensive Plan and the City of Chesterfield Municipal Code.

Furthermore, Section 31-03-04-K.5 of the City of Chesterfield Municipal Code lists 12 Design Features suggested to be utilized by developers when applying for “PUD” zoning. This section of code also states the following: “Satisfaction of all or any of these design features is not mandatory, but the approval of “PUD” zoning will be predicated on the use of the below list or any other design feature deemed desirable by the City of Chesterfield. Proposed inclusion of these design features within a “PUD” can increase the flexibility of design standards and the ability of the developer to negotiate the mitigation of other requirements.” A list of the suggested design features is available under the “PUD” District Regulations at the following link:

[http://www.chesterfield.mo.us/webcontent/plnpwk/docs/UDC/Article%2003%20\(Zoning%20Districts%20and%20Uses\).pdf](http://www.chesterfield.mo.us/webcontent/plnpwk/docs/UDC/Article%2003%20(Zoning%20Districts%20and%20Uses).pdf)

Staff requested the Applicant provide an updated “PUD” Narrative that details which of these 12 design features have been utilized and how. The response from the Applicant addressing this request is included in the Project Narrative, as well as the response letter to the April 13<sup>th</sup>, 2015 meeting which are both attached to this report.

As detailed in the following section of this report, it is Staff’s opinion that the Petitioner’s “PUD” request is compatible with the flexibility that the “PUD” District is designed to offer.

### **Staff Analysis of “PUD” Request**

Staff has reviewed this request and finds it to be compliant to all City Code requirements. The Petitioner has made a modest request for 16 homes on 17.35 acres. The minimum density that is currently required and that will be maintained with the “PUD” designation is 1 dwelling unit per acre.

This development will be accessed by one gated entrance off Wilson Avenue which will be enhanced not only by landscaped islands but with landscaping on each side of the private drive in front of the proposed gate house. Furthermore, the perimeter of the development will include an extensively planted 30 foot landscape buffer; this buffer will provide privacy for both the residents of Falling Leaves Estates and surrounding neighbors. The Petitioner will take advantage of the existing lake and provide a large passive open area around the lake for the enjoyment of the residents. The proposal includes a total of 38% Common Open Space which equals to 6.52 acres of the 17.35 acre development. The Common Open Space will be deed restricted to only include improvements that are necessary and appropriate for the benefit and enjoyment of the residents or land owners; it cannot include any portion of an improved lot, dedicated to buildings or vehicular navigation. The surrounding developments and traditional residential districts (straight zoning districts) do not have Common Open Space/Common Ground requirements; in addition these districts have limited landscape buffer requirements. The City of Chesterfield Municipal Code states Common Open Space can include any improvements as necessary and appropriate for the benefit and enjoyment of the residents or land owners. Common open space does not include any portion of an improved lot, dedicated to buildings or vehicular navigation; however, Common Ground can include private development if approved by the Home Owner’s Association and it can also include areas dedicated for vehicular traffic. And Common Open Space has to deed restrict to never be subdivided or developed in the future, but the same does not apply to Common Ground. A homeowner can acquire Common Ground and develop that area to accommodate private improvements.

Furthermore, Section 31-03-04-K.1 of the City of Chesterfield Municipal Code states “the purpose of the “PUD” District is to encourage flexibility to the density requirements and development standards of the zoning ordinance that will result in exceptional design, character, and quality of new homogenous and mixed use developments; to promote the most appropriate use of land; to facilitate the provision of streets and utilities; and to preserve the natural and scenic features and open space.” **The Petitioner is not seeking any variances or exceptions from the “PUD” requirements or any other City Code requirements, including access management, Tree Preservation and Landscape Requirements or Subdivision Design Standards.** In addition, as discussed above, there will be 38% Common Open Space provided for this development. If developed under the “R-1” Residence District, this would not require any Common Open Space or Common Ground and the perimeter buffer requirements would be less.

**Existing Conditions**

The minimum lot sizes are established by the planned district ordinance governing the “PUD” District and the proposed minimum lot size for this “PUD” is 22,000 square feet. Table 1, below, identifies minimum lot sizes for the adjacent developments and the proposed Falling Leaves Estates II development.

Development	Lots	Acres	Density	Minimum Lot Size in Square Feet	Open Space/ Landscape Buffer Requirement
Wilson Farm Estates	182	200	0.91	22,500	None/None
Bent Tree	92	42.5	2.16	12,000 (R-1A); 26,000 (R-1); 30,000 (lots along Wilson)	None/None
Chesterfield Meadows	106	100	1.06	22,000 (internal lots); 1 acre (perimeter lots)	None/None
Wilson Manors II	74	84.3	0.88	22,000; 38,000 (lots along northern limits)	None/30 ft. along northern limits
<i>Falling Leaves Estates II</i>	<i>16</i>	<i>17.37</i>	<i>0.92</i>	<i>22,000</i>	<i>30%/30 ft. around entire perimeter</i>

**Table 1: Adjacent Development Figures**

As identified, the proposed minimum lot size for Falling Leaves Estates II is 22,000 square feet and as seen in the Preliminary Plan, the largest lot is 27,205 square feet with an average lot size of 24,232 square feet for the development. It is important to note that the other subdivisions listed in the table above are not “PUDs” and therefore do not have the 30 foot Landscape Buffer requirement or a 30 percent Common Open Space requirement. Additionally, some of these subdivisions required larger lots along the perimeters; however, these lot lines extend to the edge of the development as there are no Landscape Buffer requirements. The perimeter lots for Falling Leaves Estates II are over 24,000 square feet with the exception of 3 lots which are 22,410 square feet, 23,646 square feet, and 22,084 square feet; and none of the lots in the proposed development include the Landscape Buffer in private lots. If the Landscape Buffers were included in the private lots, the minimum lot size would be larger than 22,000 square feet. Therefore, this development is compatible with surrounding developments.

**Issues**

The Planning Commission, with input from the public, identified multiple issues at the March 9<sup>th</sup>, 2015 Public Hearing on this petition. Those issues, as well as outstanding Staff issues, were forwarded to the Petitioner. A summary of the issues identified include:

- Purpose of the requested “PUD” District designation
- Number of buildable homes under the “R-1” Residence District
- The one lot proposed near the northeastern corner of the development
- Number of curb cuts along Wilson Road
- Stormwater
- Existing small pond near the southeastern corner of the development
- Perimeter Buffer and fence along the southern perimeter of the development

The items listed on the previous page, as well as outstanding Staff issues, were discussed at the April 13<sup>th</sup>, 2015 Issues Meeting. The Planning Commission did identify a few additional concerns related to the petition. A summary of the issues are:

- Location of Lot 16 – setback from Wilson Avenue and its proximity to the entrance gate
- Stormwater on Wilson Avenue
- Purpose of the requested “PUD” District designation

The Petitioner has submitted a formal response to each of these items and this response is attached to Staff’s report for review. Additionally, all outstanding Staff issues regarding the Preliminary Plan have been addressed.

The remainder of this report provides an analysis on a few significant issues discussed during these meetings, as well as highlights key features proposed with the Falling Leaves Estates II development.

### **Preliminary Plan**

The following are items which represent a summary of key features being provided with the updated Preliminary Plan and how it addresses the issues discussed on Page 6:

- 16 lots are proposed; original proposal was for 17 lots
  - Min lot size of 22,000 square feet
  - Max lot size of 27,205 square feet

Since the Public Hearing, the Petitioner has decreased the number of proposed lots, which in turn has decreased the density of the development to 0.92. This density is compatible to the surrounding developments (as seen in Table 1 on Page 5 as well). The density for surrounding developments in order from most dense to least is as follows: Bent tree – 2.16; Chesterfield Meadows – 1.06; *Falling Leaves Estates II* – 0.92; Wilson Farm Estates – 0.91; Wilson Manors II – 0.88.

- The setbacks proposed within this development are as follows:
  - Front Yard – 25 feet
  - Side Yard – 10 feet
  - Rear Yard – 20 feet

As discussed at the April 13<sup>th</sup>, 2015 Planning Commission meeting, there were some discrepancies in the front yard setbacks. Some areas showed a 20 foot front yard setback and some areas showed a 25 foot front yard setback. The Petitioner has cleared up this inconsistency and is proposing a 25 foot front yard setback for all the lots.

- The Landscape Buffer requirement for the “PUD” has been met and has been achieved by Common Open Space, which will be deed restricted. Additionally, the buffer is provided outside of all private lots. The Petitioner has provided an exhibit on the Preliminary Plan showing what a typical 100 foot buffer section would be. Per City Code requirements, the Landscape Buffers are required to contain a combination of deciduous, evergreen and ornamental trees and shrubs. The exact buffer plantings will be reviewed during the Site Development Plan phase if this change of zoning request is approved.

To address the Planning Commission concern about the proximity of Lot 16 to the entrance gate, the Petitioner will provide an additional 15 foot Landscape Easement, located on each side of the private entrance. This area will contain landscaping and will provide a buffer, especially

for Lot 16, from the gated entrance. The exact location and type of landscaping will be determined during Site Development Plan review, if this zoning map amendment request is approved. (This easement area is highlighted in yellow on Figure 4 below).

Furthermore, the Petitioner has noted that existing mature trees within the Landscape Buffer east of Lot 16 will be retained and will be enhanced with supplemental landscaping and buffer trees to provide for an attractive and comprehensive landscape design along Wilson Road.

- As discussed above, the Petitioner redesigned the Preliminary Plan to remove the lot proposed near the northeast corner of the site. This, in turn with the combination of proposed density, would allow for 38% of the site (6.52 acres) being reserved as Common Open Space – this includes the existing lake on the site. The previous Preliminary Plan only had 34% Common Open Space.

An additional 0.23 acres (1%) of Common Ground is proposed and is located near the lake, near the entrance, as well as landscape islands within cul-de-sacs. Figure 4, below, highlights the areas dedicated as Common Open Space (darker green and blue for the lake) and Common Ground (lighter green).

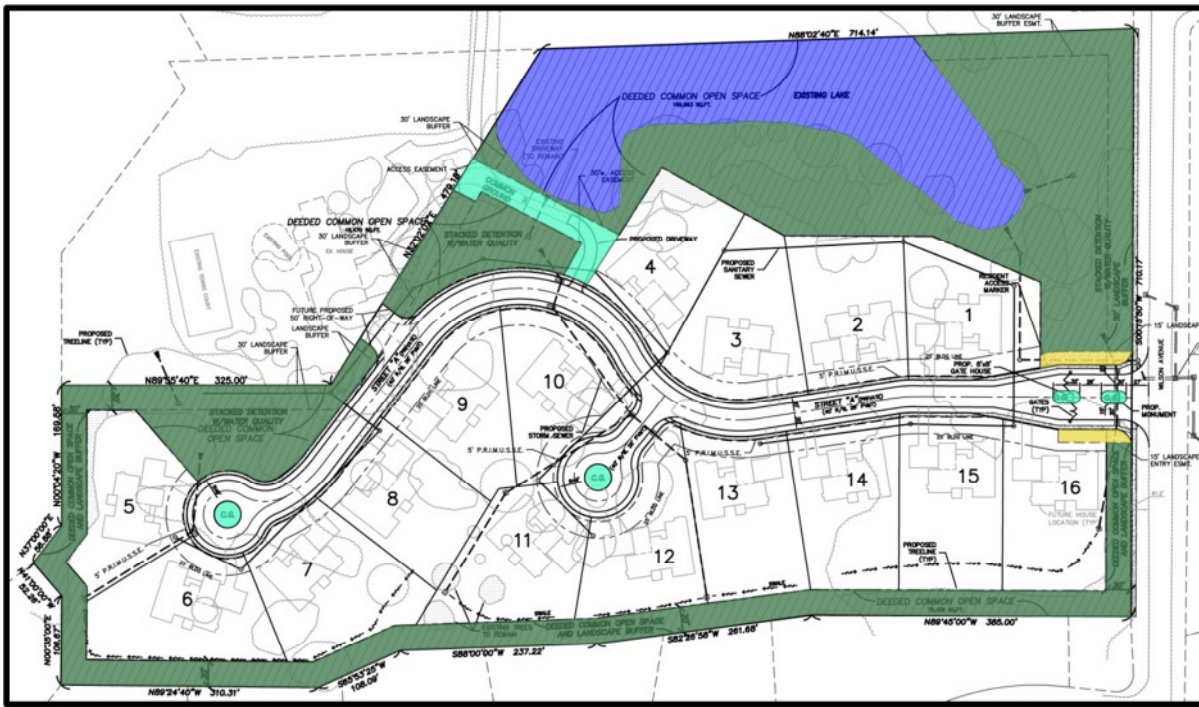

**Figure 4 – Common Ground & Common Open Space**

- The Preliminary Plan submitted for review during the Public Hearing noted only 27% of the existing tree canopy would be retained. The City of Chesterfield Municipal Code requires a minimum of 30% of tree canopy be retained. However, during the Public Hearing the Petitioner noted they were re-evaluating this and will be able to retain at least 30% of the tree canopy. This is reflected in the updated Preliminary Plan. Tree Preservation will be reviewed in detail during the Site Development Plan submittal, if this zoning request is approved.
- The Preliminary Plan shows sidewalks along both sides of the private street and along the Wilson Avenue frontage of the development. The sidewalk along Wilson Avenue will be 5 feet wide and the interior sidewalks will be 4 feet wide. These sidewalks will be ADA compliant.



- During the Public Hearing and the Issues Meeting, the Petitioner was asked to explain why they are seeking a change of zoning to a “PUD” District. The Petitioner has provided a detailed reply as to why they are requesting a change of zoning to a “PUD” on Page 2 of the Response Letter. This is the same response the Petitioner had provided during the Issues Meeting.
- During the Public Hearing, there were concerns raised regarding the number of curb cuts along Wilson Avenue. The Preliminary Plan presented during the Public Hearing was for 17 lots, which included a single lot near the northeastern corner of the development. As discussed previously in this report, the Petitioner has amended the request and Preliminary Plan and is now proposing only 16 lots on the 17.37 acres. All the lots will be accessed via a private, gated entrance off of Wilson Avenue. There will be no additional curb cuts along Wilson Avenue. And as seen during the Public Hearing, the existing private drive used to currently access the subject site will be relocated further south along Wilson Avenue.
- There were some concerns raised at the Public Hearing regarding the additional stormwater this development would create and how it would be handled. The development will contain 3 stacked detention basins to handle all the stormwater on the site. Furthermore, all of the City of Chesterfield and the Metropolitan Sewer District (MSD) stormwater requirements will have to be met and will be evaluated in detail during the Site Development Plan review, if this change of zoning request is approved.

Additionally, at the Issues Meeting there was discussion about the stormwater on Wilson Avenue and possibility of obtaining a stormwater easement for future improvements to the existing stormwater system along the roadway. There is currently a stormwater pipe under Wilson Avenue which takes water from the existing stormwater inlets and discharges into a swale on the subject site. This swale drains to the existing lake. With this development, the Petitioner will install a new stormwater pipe, in lieu of the swale, which will discharge into the lake as well. The existing stormwater pipes on Wilson Avenue are within right-of-way and the new stormwater pipe will be located within a utility easement. The size of the new stormwater pipe and location of all easements will be reviewed in detail with future plan submittals, if this zoning request is approved.

Furthermore, there were questions asked about the future of the small pond near the southeastern corner of the development (on what is proposed as Lot 16 in the new plan). The existing pond on the proposed Lot 16 will be drained and eliminated per the Petitioner’s response. This pond will be filled and graded to match adjacent grades on proposed Lot 16.

## **Request**

Staff has reviewed the requested zoning map amendment by the Applicant as it pertains to the “PUD” request and has prepared an Attachment A reflecting this request. The petition has met all filing requirements and procedures of the City of Chesterfield. Additionally, all agency comments have been received and comments are represented in the provided Attachment A. Staff requests action on P.Z. 02-2015 Falling Leaves Estates II (1925 & 1921 Wilson Avenue).

### **Attachments**

1. Attachment A
2. Response to Issues Letter
3. Project Narrative
4. Preliminary Plan
5. Tree Stand Delineation Plan

cc: Aimee Nassif, Planning and Development Services Director

## ATTACHMENT A

**All provisions of the City of Chesterfield City Code shall apply to this development except as specifically modified herein.**

### **I. SPECIFIC CRITERIA**

#### **A. PERMITTED USES**

1. The uses allowed in this Planned Unit Development (PUD) District shall be:
  - a. Dwellings, Single Family Detached.

#### **B. DENSITY REQUIREMENTS**

The total number of single family residential units shall not exceed sixteen (16) units.

#### **C. DEVELOPMENT STANDARDS**

1. Minimum lot size for this development shall be 22,000 square feet.
2. Maximum height of all structures shall be forty-five (45) feet.
3. Structure setbacks shall be as follows:
  - a. Twenty-five (25) feet from the front yard.
  - b. Ten (10) feet from the side yard.
  - c. Twenty (20) feet from the rear yard
4. No building or structure, other than: a freestanding project identification sign, light standards, retaining walls or flag poles shall be located within the above listed setbacks.

#### **D. PARKING AND LOADING REQUIREMENTS**

1. Parking and loading spaces for this development will be as required in the City of Chesterfield Code.
2. No construction related parking shall be permitted within the right of way or on any existing roadways surrounding the development including but not limited to Wilson Avenue. All construction related parking shall be confined to the development.

## **E. LANDSCAPE AND TREE REQUIREMENTS**

1. The development shall adhere to the Landscape and Tree Preservation Requirements of the City of Chesterfield Code.
2. Landscape Buffer requirements:
  - a. A thirty (30) foot Landscape Buffer shall be required around the entire perimeter of the PUD except as identified on the Preliminary Plan attached hereto and marked as Attachment B.
  - b. The required Landscape Buffer shall be outside of any developed lot and shall be dedicated as Common Open Space as identified on the Preliminary Plan attached hereto and marked as Attachment B.
3. Landscape and Entry Monument Easements are established as a protected area for vegetative landscaping and entrance monument structures. Landscaping as approved by the City of Chesterfield during site development plan review is required to be maintained and preserved indefinitely by the resident or Home Owners Association. Failure to maintain or preserve landscape easements may result in inspection and issuance of fines by the City of Chesterfield. This language shall be included on all plans, plats, ordinances, subdivision indentures and other appropriate (written) documents for this development.
4. A minimum of thirty-eight percent (38%) Common Open Space shall be required for this PUD.

## **F. SIGN REQUIREMENTS**

1. Signs shall be permitted in accordance with the regulations of the City of Chesterfield Code.
2. Ornamental Entrance Monument construction, if proposed, shall be reviewed by the City of Chesterfield for sight distance considerations prior to installation or construction.

## **G. LIGHT REQUIREMENTS**

Provide a lighting plan and cut sheets in accordance with the City of Chesterfield Code.

## **H. ARCHITECTURAL**

The development shall adhere to the Architectural Review Standards of the City of Chesterfield Code.

## **I. ACCESS/ACCESS MANAGEMENT**

1. Access to the development shall be from Wilson Avenue, as shown on the Preliminary Plan attached hereto and marked as Attachment B, and adequate sight distance shall be provided, as directed by the City of Chesterfield.
2. If adequate sight distance cannot be provided at the access location(s), acquisition of right-of-way, reconstruction of pavement and other off-site improvements may be required to provide the required sight distance as required by the City of Chesterfield.
3. No lot shall be allowed direct access to Wilson Avenue.

## **J. PUBLIC/PRIVATE ROAD IMPROVEMENTS, INCLUDING PEDESTRIAN CIRCULATION**

1. Any request to install a gate at the entrance to this development must be approved by the City of Chesterfield and the agency in control of the right of way off of which the entrance is constructed if other than the City of Chesterfield. No gate installation will be permitted on public right of way.
2. If a gate is installed on a street in this development, the streets within the development, or that portion of the development that is gated, shall be private and remain private forever.
3. Provide street connections to the adjoining properties as shown on the Preliminary Plan and as directed by the City of Chesterfield. Stub street signage, in conformance with Section 31-04-09 of the City of Chesterfield Municipal Code, shall be posted within thirty (30) days of the street pavement being placed.
4. All roadway and related improvements in each plat or phase of the development shall be constructed prior to issuance of building permits exceeding sixty percent (60%) for that plat or phase. Delays due to utility relocation and/or adjustment, for which the developer is responsible monetarily, shall not constitute a cause to issue permits in excess of sixty percent (60%).
5. Obtain approvals from the City of Chesterfield and other entities as necessary for locations of proposed curb cuts and access points, areas of new dedication, and roadway improvements.
6. Provide access rights to the existing property west of this development to ensure future access to the proposed private roadway.

7. Additional right of way and road improvements shall be provided, as required by the City of Chesterfield.
8. Provide a five (5) foot wide sidewalk, conforming to ADA standards, along the Wilson Avenue frontage of the site. The sidewalk shall provide for future connectivity to adjacent developments and/or roadway projects. The sidewalk may be located on private property within a six (6) foot wide sidewalk, maintenance and utility easement dedicated to the City of Chesterfield.
9. Provide a four (4) foot wide sidewalk, conforming to ADA standards, along the private drive, as shown on the Preliminary Plan attached hereto and marked as Attachment B.

#### **K. TRAFFIC STUDY**

Provide a traffic study as directed by the City of Chesterfield. The scope of the study shall include internal and external circulation and may be limited to site specific impacts, such as the need for additional lanes, entrance configuration, geometrics, sight distance, traffic signal modifications or other improvements required, as long as the density of the proposed development falls within the parameters of the City's traffic model. Should the density be other than the density assumed in the model, regional issues shall be addressed as directed by the City of Chesterfield.

#### **L. POWER OF REVIEW**

Either Councilmember of the Ward where a development is proposed or the Mayor may request that the plan for a development be reviewed and approved by the entire City Council. This request must be made no later than twenty-four (24) hours after Planning Commission review. The City Council will then take appropriate action relative to the proposal. The plan for a development, for purposes of this section, may include the Site Development Plan, Site Development Section Plan, Site Development Concept Plan, Landscape Plan, Lighting Plans, Architectural Elevations, Sign Package or any amendment thereto.

#### **M. STORM WATER**

1. The site shall provide for the positive drainage of storm water and it shall be discharged at an adequate natural discharge point or an adequate piped system.
2. Detention/retention, channel protection, and water quality measures are to be provided in each watershed as required by the City of Chesterfield and the Metropolitan St. Louis Sewer District.

The storm water management facilities shall be operational prior to issuance of building permits exceeding sixty (60%) of the approved dwelling units in each plat, watershed or phase of residential developments. The location and types of storm water management facilities shall be identified on all Site Development Plans.

3. The receiving storm system(s) shall be evaluated to ensure adequate capacity and to ensure that the project has no negative impacts to the existing system(s).
4. Emergency overflow drainage ways to accommodate runoff from the 100-year storm event shall be provided for all storm sewers, as directed by the City of Chesterfield.
5. Offsite storm water shall be picked up and piped to an adequate natural discharge point. On-site storm water piping must be adequately designed to accommodate offsite storm water to be piped through the site as applicable.
6. The lowest opening of all structures shall be set at least two (2) feet higher than the 100-year high water elevation in detention/retention facilities. All structures shall be set at least thirty (30) feet horizontally from the limits of the 100-year high water.
7. Locations of site features such as lakes and detention ponds must be approved by the City of Chesterfield and the Metropolitan St. Louis Sewer District (MSD).
8. Storm sewers shall be as approved by the City of Chesterfield, the Metropolitan St. Louis Sewer District, and other entities as necessary.
9. Provide necessary off-site easements for construction and maintenance of off-site storm sewers.
10. Formal project development plans shall be submitted to MSD for review, approval, and permits. These facilities shall be designed in accordance with the MSD Rules and Regulations and Engineering Design Requirements for Sanitary Sewer and Drainage Facilities that apply at the time of formal submission to MSD.
11. Easement to MSD will be required for any public sewers. The project is located in the Caulks Creek Impact area and subject to applicable fees.

12. Stormwater quality, channel protection, and flood detention requirements will apply. Controls shall be designed and implemented to reasonably mimic pre-construction runoff conditions (including runoff volume) to the maximum extent practicable. MSD will assess stormwater quality and flood detention effectiveness based on the site's January 2000 pre-construction condition.
13. The site is tributary to MSD's Wheatley Ct. Pump Station (P-748). The developer may be required to provide improvements to the pump station in order to accommodate the additional demand placed on the facility by this development.
14. A stream/drainage ditch, pond, and lake are identified on the Natural Resource Map. The developer should investigate for and assess the jurisdictional nature of these features, and confirm with the U.S. Army Corps of Engineers and Missouri Department of Natural Resources the applicability of their requirements. If jurisdictional, efforts should be made to protect these natural resources.

#### **N. SANITARY SEWER**

1. The receiving sanitary sewer system(s) shall be evaluated to ensure adequate capacity and to ensure the project has no negative impacts to the existing system(s).
2. Sanitary sewers shall be as approved by the Metropolitan St. Louis Sewer District, the City of Chesterfield, and other entities as necessary.

#### **O. GEOTECHNICAL REPORT**

Prior to Site Development Plan approval, the developer shall provide a geotechnical report, prepared by a registered professional engineer licensed to practice in the State of Missouri, as directed by the City of Chesterfield. The report shall verify the suitability of grading and proposed improvements with soil and geologic conditions and address the existence of any potential sinkhole, ponds, dams, septic fields, etc., and recommendations for treatment. A statement of compliance, signed and sealed by the geotechnical engineer preparing the report, shall be included on all Site Development Plans and Improvement Plans.

**P. MISCELLANEOUS**

1. All utilities will be installed underground.
2. Prior to record plat approval, the developer shall cause, at his expense and prior to the recording of any plat, the reestablishment, restoration or appropriate witnessing of all Corners of the United States Public Land Survey located within, or which define or lie upon, the out boundaries of the subject tract in accordance with the Missouri Minimum Standards relating to the preservation and maintenance of the United States Public Land Survey Corners, as necessary.
3. Prior to final release of subdivision construction deposits, the developer shall provide certification by a registered land surveyor that all monumentation depicted on the record plat has been installed and United States Public Land Survey Corners have not been disturbed during construction activities or that they have been reestablished and the appropriate documents filed with the Missouri Department of Natural Resources Land Survey Program, as necessary.
4. Road improvements and right-of-way dedication shall be completed prior to the issuance of an occupancy permit. If development phasing is anticipated, the developer shall complete road improvements, right-of-way dedication, and access requirements for each phase of development as directed by the City of Chesterfield. As previously noted, the delays due to utility relocation and adjustments will not constitute a cause to allow occupancy prior to completion of road improvements.
5. Obtain any and all necessary determinations, approvals, and permits from USACE, the Missouri Department of Natural Resources, and other entities, as necessary, for work impacting or in close proximity to jurisdictional waterways and/or wetlands.

**II. TIME PERIOD FOR SUBMITTAL OF SITE DEVELOPMENT CONCEPT PLANS AND SITE DEVELOPMENT PLANS**

- A.** The developer shall submit a concept plan within eighteen (18) months of City Council approval of the change of zoning.
- B.** In lieu of submitting a Site Development Concept Plan and Site Development Section Plans, the petitioner may submit a Site Development Plan for the entire development within eighteen (18) months of the date of approval of the change of zoning by the City.



- C.** Failure to comply with these submittal requirements will result in the expiration of the change of zoning and will require a new public hearing.
- D.** Said Plan shall be submitted in accordance with the combined requirements for Site Development Section and Concept Plans. The submission of Amended Site Development Plans by sections of this project to the Planning Commission shall be permitted if this option is utilized.
- E.** Where due cause is shown by the developer, the City Council may extend the period to submit a Site Development Concept Plan or Site Development Plan for eighteen (18) months.

### **III. COMMENCEMENT OF CONSTRUCTION**

- A.** Substantial construction shall commence within two (2) years of approval of the Site Development Concept Plan or Site Development Plan, unless otherwise authorized by ordinance.
- B.** Where due cause is shown by the developer, the City Council may extend the period to commence construction for not more than two (2) additional years.

### **IV. GENERAL CRITERIA**

#### **A. SITE DEVELOPMENT CONCEPT PLAN**

1. Any Site Development Concept Plan shall show all information required on a preliminary plat as required in the City of Chesterfield Code.
2. Include a Conceptual Landscape Plan in accordance with the City of Chesterfield Code to indicate proposed landscaping along arterial and collector roadways.
3. Include a Lighting Plan in accordance with the City of Chesterfield Code to indicate proposed lighting along arterial collector roadways.
4. Provide comments/approvals from the appropriate Fire District, the St. Louis County Department of Highways and Traffic, Monarch Chesterfield Levee District, Spirit of St. Louis Airport and the Missouri Department of Transportation.
5. Compliance with the current Metropolitan Sewer District Site Guidance as adopted by the City of Chesterfield.

## **B. SITE DEVELOPMENT PLAN SUBMITTAL REQUIREMENTS**

The Site Development Plan shall include, but not be limited to, the following:

1. Location map, north arrow, and plan scale. The scale shall be no greater than one (1) inch equals 100 feet.
2. Outboundary plat and legal description of property.
3. Density calculations.
4. Parking calculations. Including calculation for all off street parking spaces, required and proposed, and the number, size and location for handicap designed.
5. Provide openspace percentage for overall development including separate percentage for each lot on the plan.
6. Provide Floor Area Ratio (F.A.R.).
7. A note indicating all utilities will be installed underground.
8. A note indicating signage approval is separate process.
9. Depict the location of all buildings, size, including height and distance from adjacent property lines, and proposed use.
10. Specific structure and parking setbacks along all roadways and property lines.
11. Indicate location of all existing and proposed freestanding monument signs.
12. Zoning district lines, subdivision name, lot number, dimensions, and area, and zoning of adjacent parcels where different than site.
13. Floodplain boundaries.
14. Depict existing and proposed improvements within 150 feet of the site as directed. Improvements include, but are not limited to, roadways, driveways and walkways adjacent to and across the street from the site, significant natural features, such as wooded areas and rock formations, and other karst features that are to remain or be removed.

15. Depict all existing and proposed easements and rights-of-way within 150 feet of the site and all existing or proposed off-site easements and rights-of-way required for proposed improvements.
16. Indicate the location of the proposed storm sewers, detention basins, sanitary sewers and connection(s) to the existing systems.
17. Depict existing and proposed contours at intervals of not more than one (1) foot, and extending 150 feet beyond the limits of the site as directed.
18. Address trees and landscaping in accordance with the City of Chesterfield Code.
19. Comply with all preliminary plat requirements of the City of Chesterfield Subdivision Regulations per the City of Chesterfield Code.
20. Signed and sealed in conformance with the State of Missouri Department of Economic Development, Division of Professional Registration, Missouri Board for Architects, Professional Engineers and Land Surveyors requirements.
21. Provide comments/approvals from the appropriate Fire District, Monarch Levee District, Spirit of St. Louis Airport, Metropolitan St. Louis Sewer District (MSD) and the Missouri Department of Transportation.
22. Compliance with Sky Exposure Plane.
23. Compliance with the current Metropolitan Sewer District Site Guidance as adopted by the City of Chesterfield.

**C. SITE DEVELOPMENT SECTION PLAN SUBMITTAL REQUIREMENTS**

The Site Development Section Plan shall adhere to the above criteria and to the following:

1. Location map, north arrow, and plan scale. The scale shall be no greater than one (1) inch equals 100 feet.
2. Parking calculations. Including calculation for all off street parking spaces, required and proposed, and the number, size and location for handicap designed.
3. Provide openspace percentage for overall development including separate percentage for each lot on the plan.

4. Provide Floor Area Ratio (F.A.R.).
5. A note indicating all utilities will be installed underground.
6. A note indicating signage approval is separate process.
7. Depict the location of all buildings, size, including height and distance from adjacent property lines and proposed use.
8. Specific structure and parking setbacks along all roadways and property lines.
9. Indicate location of all existing and proposed freestanding monument signs.
10. Zoning district lines, subdivision name, lot number, lot dimensions, lot area, and zoning of adjacent parcels where different than site.
11. Floodplain boundaries.
12. Depict existing and proposed improvements within 150 feet of the site as directed. Improvements include, but are not limited to, roadways, driveways and walkways adjacent to and across the street from the site, significant natural features, such as wooded areas and rock formations, and other karst features that are to remain or be removed.
13. Depict all existing and proposed easements and rights-of-way within 150 feet of the site and all existing or proposed off-site easements and rights-of-way required for proposed improvements.
14. Indicate the location of the proposed storm sewers, detention basins, sanitary sewers and connection(s) to the existing systems.
15. Depict existing and proposed contours at intervals of not more than one (1) foot, and extending 150 feet beyond the limits of the site as directed.
16. Address trees and landscaping in accordance with the City of Chesterfield Code.
17. Comply with all preliminary plat requirements of the City of Chesterfield Subdivision Regulations per the City of Chesterfield Code.

18. Signed and sealed in conformance with the State of Missouri Department of Economic Development, Division of Professional Registration, Missouri Board for Architects, Professional Engineers and Land Surveyors requirements.
19. Provide comments/approvals from the appropriate Fire District, Monarch Levee District, Spirit of St. Louis Airport, St. Louis Department of Highways and Traffic, Metropolitan St. Louis Sewer District (MSD) and the Missouri Department of Transportation.
20. Compliance with Sky Exposure Plane.
21. Compliance with the current Metropolitan Sewer District Site Guidance as adopted by the City of Chesterfield.

## **V. TRUST FUND CONTRIBUTION**

- A.** The developer shall contribute a Traffic Generation Assessment (TGA) to the Eatherton-Kehrs Mill Road Trust Fund (No. 522). This contribution shall not exceed an amount established by multiplying the required parking spaces by the following rate schedule:

<b><u>Type of Development</u></b>	<b><u>Required Contribution</u></b>
Single Family Dwelling	\$1,085.70/Parking Space

(Parking Space as required by the site-specific ordinance or by section 1003.165 of the St. Louis County Zoning Ordinance.)

If types of development proposed differ from those listed, rates shall be provided by the St. Louis County Department of Highways and Traffic.

If a portion of the improvements required herein are needed to provide for the safety of the traveling public, their completion as a part of this development is mandatory.

Allowable credits for required roadway improvements will be awarded as directed by the St. Louis County Department of Highways and Traffic and the City of Chesterfield. Sidewalk construction and utility relocation, among other items, are not considered allowable credits.

- B.** As this development is located within a trust fund area established by St. Louis County, any portion of the traffic generation assessment contribution which remains following completion of road improvements required by the development should be retained in the appropriate trust fund.

- C.** Traffic generation assessment contributions shall be deposited with St. Louis County prior to the issuance of building permits. If development phasing is anticipated, the developer shall provide the traffic generation assessment contribution prior to issuance of building permits for each phase of development. Funds shall be payable to Treasurer, St. Louis County.
- D.** The amount of the required contribution/improvements, if not approved for construction by January 1, 2016, shall be adjusted on that date and on the first day of January in each succeeding year thereafter in accord with the construction cost index as determined by the St. Louis County Department of Highways and Traffic.

## **VI. RECORDING**

Within sixty (60) days of approval of any development plan by the City of Chesterfield, the approved Plan will be recorded with the St. Louis County Recorder of Deeds. Failure to do so will result in the expiration of approval of said plan and require re-approval of a plan by the Planning Commission.

## **VII. ENFORCEMENT**

- A.** The City of Chesterfield, Missouri will enforce the conditions of this ordinance in accordance with the Plan approved by the City of Chesterfield and the terms of this Attachment A.
- B.** Failure to comply with any or all the conditions of this ordinance will be adequate cause for revocation of approvals/permits by reviewing Departments and Commissions.
- C.** Non-compliance with the specific requirements and conditions set forth in this Ordinance and its attached conditions or other Ordinances of the City of Chesterfield shall constitute an ordinance violation, subject, but not limited to, the penalty provisions as set forth in the City of Chesterfield Code.
- D.** Waiver of Notice of Violation per the City of Chesterfield Code.
- E.** This document shall be read as a whole and any inconsistency to be integrated to carry out the overall intent of this Attachment A.

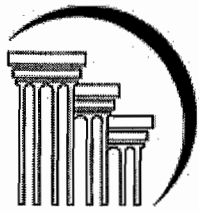

**DOSTER ULLOM  
& BOYLE, LLC**  
ATTORNEYS AT LAW

St. Louis  
16090 Swingley Ridge Road  
Suite 620  
Chesterfield, MO 63017  
(636) 532-0042  
(636) 532.1082 Fax

Michael J. Doster  
mdoster@dubllc.com

April 15, 2015

Via E-mail & U.S. Mail

Purvi Patel  
Project Planner  
City of Chesterfield  
690 Chesterfield Parkway W  
Chesterfield, Missouri 63017

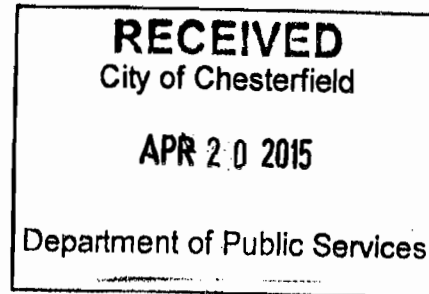

**RE: P.Z. 02-2015 Falling Leaves Estates II (1925 & 1921 Wilson Avenue)**

Dear Ms. Patel:

The following information is provided as a response to three issues that were identified at the "issues" meeting on this Application. The issues and response are as follows:

1. How will storm water originating on the site ("on site storm water") and storm water originating off site and flowing into the site ("off site storm water") be handled?

**The March 24, 2015 Preliminary Plan submitted to the City shows that both on site and off site storm water will be collected and piped to the lake on the North. Petitioner Cannot comment at this time regarding handling of storm water along Wilson Avenue in the event Wilson Avenue is widened and improved without reviewing the detailed plans for such widening and improvement.**

2. How can you address the concerns regarding Lot 16 with respect to its setback from Wilson Avenue and its proximity to the entrance gate?

**The proposed project has Seven Hundred and Ten Feet of frontage on its West Side adjoining Wilson Avenue. Four Hundred Feet of frontage has been left open as Deeded Common Open Space with a broad view for passersby looking out over the Existing Lake. The preservation of the lake feature and its recognition as a scenic landmark on Wilson Avenue has been paramount in the design of the neighborhood. The remaining frontage of the property has been utilized for access and the neighborhood. Of the remaining frontage - Eighty Five Feet is proposed to be utilized for a heavily landscaped and architecturally**

**enhanced Gated Entrance to the proposed neighborhood. To the south of the neighborhood Entrance is a 30 Ft x 225 Ft Deeded Common Open Space and Landscape Buffer (“Wilson Avenue Buffer”) that will retain any existing mature trees within this area. The proposed project does not have any lots that directly adjoin Wilson Road Right of way. The Wilson Avenue Buffer will be enhanced with supplemental landscaping and buffer trees to make for an attractive and comprehensive landscape design along Wilson Road. Furthermore at the proposed gated entrance there will be a 15 ft wide Entrance Landscape easement located on each side of the entrance road that will allow the landscaping to return into the Gated entrance way and buffer the entrance gates and gate house from Lot 16.**

3. How does Petitioner justify the request for a PUD?

**Petitioner’s previous response to this question is reproduced here:**

**There are multiple objectives. There is a desire to develop lot sizes (less than one acre) that are comparable to adjacent residential developments, preserve the existing amenities and topography (the lake, gently rolling land and natural drainways), and provide substantial open space for the enjoyment of the residents and the extensively landscaped open space buffer at the perimeter for the protection of the residents and the adjacent neighbors.**

In addition, Petitioner reproduces the responses to the first four suggested design features in the PUD ordinance that were included in Petitioner’s narrative statement:

- (a) Placement of structures on most suitable sites with consideration of maintaining existing site topography, soils, vegetation, slope, etc.

**The Petitioner plans to take advantage of the existing rolling topography and site features in locating residences within the development. Grading will follow as much as possible the existing contours, and the meandering streets will follow the general route of the existing driveways on the site. The development plan will take advantage of the existing lake and provide substantial accessible open space next to the lake that residents may enjoy that amenity. Storm water drainage and detention will take advantage of existing natural drainways.**

- (b) Preservation of natural and cultural areas, as well as the creation of open space through active and passive recreation areas to include greenways, landscape gardens, plazas, and walking and cycling trails that serve to connect significant areas and various land uses.

**Landscaped open space will be created at the perimeter of the development, and, as noted in (a) above, substantial open space will be created next to the existing**



lake so that residents may take advantage of this amenity. The open space next to the lake will be passive and will be maintained so that residents can walk over it and enjoy the natural beauty of this setting. No permanent walkway or trail will be provided, but a pedestrian access point with marker and parking area for bicycles and strollers will be provided. There are existing, beautiful mature trees in this area that will be maintained. There will also be a landscaped and gated entrance with gatehouse that will provide an attractive front door to this new community.

- (c) Preservation of existing mature trees and trees deemed extraordinary by the City of Chesterfield Tree Specialist due to but not limited to the following: size, type, origin, grouping, or number of.

**Existing mature trees will be preserved, and John Fischer will comply with the City's tree preservation requirements.**

- (d) Enhanced landscaping, deeper and opaque buffers, and increased planting along public rights-of-way, open space/recreational areas, and the overall perimeter to protect and ensure compatibility with adjacent land uses.

**Enhanced landscaping will be planted in the open space buffer and along Wilson Road to provide a buffer and an attractive scape for the viewing of the residents, adjacent residents and passersby.**

Very truly yours,

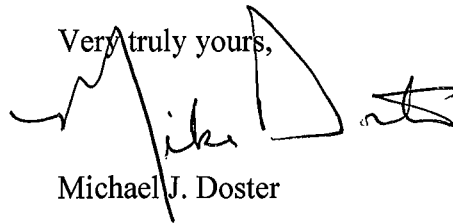
A handwritten signature in black ink, appearing to read "Mike Doster", written over the typed name "Michael J. Doster". The signature is stylized and somewhat cursive.

Michael J. Doster

MJD/kml  
cc: Aimee Nassif

**Narrative Statement  
Falling Leaves Estates II**

**a. General Description**

John Fischer is proposing to develop 17.37 acres of property off Wilson Road. John Fischer and family live on the site. John Fischer's home and associated acreage would not be a lot in the development. The development will be constructed in two phases. Commencement of phase one has not yet been determined. Phase one may include lots from the main entrance up to and including lots served by or adjacent to the first cul-de-sac. John Fischer does not intend at this time to commence construction until his Mother no longer lives on the site. The existing zoning is R-1 (one acre density) A PUD is requested to accommodate this development which would consist of 16 lots. Fischer & Frichtel Homes' luxury home product line would be built in this development, and that product line will be compatible with the adjacent and nearby subdivisions. Every effort will be made to preserve and enhance existing features of the site, and the development will meet or exceed all applicable PUD requirements. The plan complies with the requirements and guidelines of the PUD Ordinance.

**b. Requested use**

John Fischer is requesting single family detached residential use for the development. Sample renderings are attached. The maximum height of any structure is 45 feet or 3 stories. The development will also contain common ground, common open space and meandering streets.

**c. Proposed land uses and development standards, density and height limitations, yard requirements (compatible with nearby uses and Comprehensive Plan):**

John Fischer is requesting a single family detached residential use for the site. The development standards are reflected in the plan. The proposed density is one-acre. The plan includes 16 lots on 17.37 acres. The lots will range in size from 22,000 sq. ft. to 27,205 sq. ft. The average lot size is 24,232 sq. ft.

**d. Exceptions or variations from the requirement of the Zoning Ordinance:**

John Fischer is not asking for any exceptions or variations.

**e. Table showing number of acres in the proposed development and each proposed land use including public features.**

The site contains 17.37 acres and will be entirely devoted to residential use. The plan includes 6.52 acres of deeded common open space which is 38% of the site. The plan also includes .23 acres of common ground which is 1% of the site.

**f. Proposed dedication or reservation of land for public use, including streets and easements.**

The plan provides for private streets, 40 foot right-of-way including 26 foot wide pavement, and John Fischer will establish all of the necessary easements.

**g. Plans for parking, loading, access ways, and means of protecting adjacent areas from lighting and other potential, adverse effects.**

The plan provides for one main gated entrance at Wilson Road. The entrance will be landscaped and include two landscaped islands, one of which will contain an entrance monument. The landscaped islands are included in common ground. The plan also includes two cul-de-sacs with landscaped islands, one at the end of the street and one mid-way to the end. The landscaped islands are included in common ground. The main entrance will be gated. No lots will have direct access to Wilson Road.

**h. Landscaping and Tree Preservation:**

John Fischer will preserve at least 30% of the existing woodland tree canopy.

In addition to the tree preservation, extensive landscaping will be provided throughout the community. A 30 ft. wide deeded and common open space with landscaping is provided at the perimeter.

The following are John Fischer's responses to the "suggested" design features listed in Section 31-03-04.K.5 of the City of Chesterfield Municipal Code:

**(a) Placement of structures on most suitable sites with consideration of maintaining existing site topography, soils, vegetation, slope, etc.**

The Petitioner plans to take advantage of the existing rolling topography and site features in locating residences within the development. Grading will follow as much as possible the existing contours, and the meandering streets will follow the general route of the existing driveways on the site. The development plan will take advantage of the existing lake and provide substantial accessible open space next to the lake that residents may enjoy that amenity. Storm water drainage and detention will take advantage of existing natural drainways.

**(b) Preservation of natural and cultural areas, as well as the creation of open space through active and passive recreation areas to include greenways, landscape gardens, plazas, and walking and cycling trails that serve to connect significant areas and various land uses.**

Landscaped open space will be created at the perimeter of the development, and, as noted in (a) above, substantial open space will be created next to the existing lake so that residents may take advantage of this amenity. The open space next to the lake will be passive and will be

maintained so that residents can walk over it and enjoy the natural beauty of this setting. No permanent walkway or trail will be provided, but a pedestrian access point with marker and parking area for bicycles and strollers will be provided. There are existing, beautiful mature trees in this area that will be maintained. There will also be a landscaped and gated entrance with gatehouse that will provide an attractive front door to this new community.

- (c) Preservation of existing mature trees and trees deemed extraordinary by the City of Chesterfield Tree Specialist due to but not limited to the following: size, type, origin, grouping, or number of.**

Existing mature trees will be preserved, and John Fischer will comply with the City's tree preservation requirements.

- (d) Enhanced landscaping, deeper and opaque buffers, and increased planting along public rights-of-way, open space/recreational areas, and the overall perimeter to protect and ensure compatibility with adjacent land uses.**

Enhanced landscaping will be planted in the open space buffer and along Wilson Road to provide a buffer and an attractive scape for the viewing of the residents, adjacent residents and passersby.

- (e) Utilization of mixed-use buildings.**

This is not applicable to this development.

- (f) Utilization of traditional neighborhood design (TND) techniques in the layout and spatial organization of the development.**

This is not applicable to this development.

- (g) Structures designed and constructed of an architectural vernacular that exceeds the typical building design and materials within the City of Chesterfield.**

Yes. John Fischer builds residences of the highest design and quality. They will exceed the "typical" within the City of Chesterfield.

- (h) Segregation of vehicular traffic from pedestrian/bicycle circulation networks, and other traffic mitigation measures.**

This is not applicable to this development.

- (i) Incorporation of transit-oriented development (TOD) or direct access to public transportation.**

This is not applicable to this development.

- (j) Provision of affordable housing.**

This is not applicable to this development.

**(k) Utilization of Leadership in Energy and Environmental Design (LEED) construction practices and development standards and the proposed LEED certification of buildings and grounds by the United States Green Building Council within the PUD.**

This is not applicable to this development.

**(l) Inclusion of community facilities and the access thereto.**

The substantial open space next to the existing lake will be accessible to the residents by a marked access point that will have a parking area for bicycles and strollers. This open space will be maintained so that residents can walk over it and enjoy the beauty of the mature trees and the lake.

# ARCHITECTURAL DESIGN

NANTUCKET – BRICK / STONE



Fischer & Frichtel Custom Homes  
695 Trade Center Blvd, Suite 200  
Chesterfield, Missouri 63005

Falling Leaves  
Chesterfield, Missouri

**FISCHER & FRICHTEL**  
*Signature Homes*

# ARCHITECTURAL DESIGN

NANTUCKET – STONE / BRICK



Fischer & Frichtel Custom Homes  
695 Trade Center Blvd, Suite 200  
Chesterfield, Missouri 63005

Falling Leaves  
Chesterfield, Missouri

**FISCHER & FRICHTEL**  
*Signature Homes*

# ARCHITECTURAL DESIGN

PROVIDENCE – BRICK / STONE



Fischer & Frichtel Custom Homes  
695 Trade Center Blvd, Suite 200  
Chesterfield, Missouri 63005

Falling Leaves  
Chesterfield, Missouri

**FISCHER & FRICHTEL**  
*Signature Homes*



# ARCHITECTURAL DESIGN

SEBASTION - STONE / STUCCO



Fischer & Frichtel Custom Homes  
695 Trade Center Blvd, Suite 200  
Chesterfield, Missouri 63005

Falling Leaves  
Chesterfield, Missouri

**FISCHER & FRICHTEL**  
*Signature Homes*

# ARCHITECTURAL DESIGN

SEBASTION - STONE / STUCCO



Fischer & Frichtel Custom Homes  
695 Trade Center Blvd, Suite 200  
Chesterfield, Missouri 63005

Falling Leaves  
Chesterfield, Missouri

**FISCHER & FRICHTEL**  
*Signature Homes*

# ARCHITECTURAL DESIGN

GREENBRIAR – BRICK / STUCCO



Fischer & Frichtel Custom Homes  
695 Trade Center Blvd, Suite 200  
Chesterfield, Missouri 63005

Falling Leaves  
Chesterfield, Missouri

**FISCHER & FRICHTEL**  
*Signature Homes*

# ARCHITECTURAL DESIGN

GREENBRIAR – STONE / STUCCO



Fischer & Frichtel Custom Homes  
695 Trade Center Blvd, Suite 200  
Chesterfield, Missouri 63005

Falling Leaves  
Chesterfield, Missouri

**FISCHER & FRICHTEL**  
*Signature Homes*

# ARCHITECTURAL DESIGN

CALAIS – BRICK / STONE



Fischer & Frichtel Custom Homes  
695 Trade Center Blvd, Suite 200  
Chesterfield, Missouri 63005

Falling Leaves  
Chesterfield, Missouri

**FISCHER & FRICHTEL**  
*Signature Homes*

# ARCHITECTURAL DESIGN

CALAIS - STONE



Fischer & Frichtel Custom Homes  
695 Trade Center Blvd, Suite 200  
Chesterfield, Missouri 63005

Falling Leaves  
Chesterfield, Missouri

**FISCHER & FRICHTEL**  
*Signature Homes*

# ARCHITECTURAL DESIGN

GLEN EAGLE – BRICK



Fischer & Frichtel Custom Homes  
695 Trade Center Blvd, Suite 200  
Chesterfield, Missouri 63005

Falling Leaves  
Chesterfield, Missouri

**FISCHER & FRICHTEL**  
*Signature Homes*

# ARCHITECTURAL DESIGN

GLEN EAGLE – STONE / STUCCO



Fischer & Frichtel Custom Homes  
695 Trade Center Blvd, Suite 200  
Chesterfield, Missouri 63005

Falling Leaves  
Chesterfield, Missouri

**FISCHER & FRICHTEL**  
*Signature Homes*



# ARCHITECTURAL DESIGN

DAVENPORT – BRICK



Fischer & Frichtel Custom Homes  
695 Trade Center Blvd, Suite 200  
Chesterfield, Missouri 63005

Falling Leaves  
Chesterfield, Missouri

**FISCHER & FRICHTEL**  
*Signature Homes*

# ARCHITECTURAL DESIGN

DAVENPORT – STONE



Fischer & Frichtel Custom Homes  
695 Trade Center Blvd, Suite 200  
Chesterfield, Missouri 63005

Falling Leaves  
Chesterfield, Missouri

**FISCHER & FRICHTEL**  
*Signature Homes*

# ARCHITECTURAL DESIGN

NORTHFIELD – BRICK



Fischer & Frichtel Custom Homes  
695 Trade Center Blvd, Suite 200  
Chesterfield, Missouri 63005

Falling Leaves  
Chesterfield, Missouri

**FISCHER & FRICHTEL**  
*Signature Homes*

ARCHITECTURAL DESIGN  
NORTHFIELD – STONE / STUCCO



Fischer & Frichtel Custom Homes  
695 Trade Center Blvd, Suite 200  
Chesterfield, Missouri 63005

Falling Leaves  
Chesterfield, Missouri

FISCHER & FRICHTEL  
*Signature Homes*

# Falling Leaves Estates II

A Tract Of Land Being Located in  
Sections 16 & 21, Township 45 North, Range 4 East,  
City Of Chesterfield,  
St. Louis County, Missouri  
Preliminary Development Plan

## GENERAL NOTES:

- THIS SITE IS IN THE FOLLOWING DISTRICTS:  
METROPOLITAN ST. LOUIS SEWER DISTRICT  
MONARCH FIRE PROTECTION DISTRICT  
ROCKWOOD R-8 SCHOOL DISTRICT  
WARD 4
- THIS SITE IS IN THE FOLLOWING UTILITY SERVICE AREAS:  
MISSOURI AMERICAN WATER COMPANY  
AMREN UE  
AT&T  
LALEDE GAS COMPANY  
CHARTER COMMUNICATIONS
- SANITARY SEWER CONSTRUCTION AND CONNECTIONS SHALL BE AS APPROVED BY THE METROPOLITAN ST. LOUIS SEWER DISTRICT AND IN ACCORDANCE WITH THE STANDARD CONSTRUCTION SPECIFICATIONS FOR SEWERS AND DRAINAGE FACILITIES.
- STORM WATER SYSTEM SHALL BE DESIGNED PURSUANT TO THE CITY OF CHESTERFIELD AND METROPOLITAN ST. LOUIS SEWER DISTRICT REQUIREMENTS AND DISCHARGE AT AN ADEQUATE NATURAL DISCHARGE POINT.
- NO SLOPES SHALL EXCEED 3 (HORIZONTAL) TO 1 (VERTICAL), UNLESS JUSTIFIED BY GEOTECHNICAL REPORT WHICH HAS BEEN ACCEPTED/APPROVED BY THE CITY OF CHESTERFIELD.
- THE LOCATION OF STORM AND SANITARY SEWER IMPROVEMENTS ARE APPROXIMATE ONLY. ACTUAL LOCATION SHALL BE DETERMINED BY FIELD CONDITIONS AND SHALL BE INDICATED ON THE IMPROVEMENT PLANS.
- GRADING SHALL BE PER CITY OF CHESTERFIELD STANDARDS. SOURCE OF TOPOGRAPHY MSD ORTHOTOP.
- STREET TREES AND STREET LIGHTS (UNLESS OTHERWISE DEPICTED) SHALL BE PER CITY OF CHESTERFIELD STANDARDS.
- NEAREST MAJOR INTERSECTION IS WILSON AVENUE AND CLARKSON ROAD.
- ALL SIDEWALKS SHALL BE CONSTRUCTED TO ADA AND THE CITY OF CHESTERFIELD STANDARDS.
- EXISTING OWNERS: FISCHER FAMILY INVESTMENTS L P  
695 TRADE CENTER BLVD 200  
CHESTERFIELD, MO 63005
- SITE TO CONFORM TO THE CITY OF CHESTERFIELD TREE REQUIREMENTS.
- MAXIMUM HEIGHT OF THE RESIDENCES WILL NOT EXCEED 45 FEET.
- LANDSCAPE AND ENTRY MONUMENT EASEMENTS ARE ESTABLISHED AS A PROTECTED AREA FOR VEGETATIVE LANDSCAPING AND ENTRANCE MONUMENT STRUCTURES. LANDSCAPING AS APPROVED BY THE CITY OF CHESTERFIELD DURING SITE PLAN REVIEW IS REQUIRED TO BE MAINTAINED AND PRESERVED INDEFINITELY BY THE RESIDENT OR HOME OWNERS ASSOCIATION. FAILURE TO MAINTAIN OR PRESERVE LANDSCAPE EASEMENTS MAY RESULT IN INSPECTION AND ISSUANCE OF FINES BY THE CITY OF CHESTERFIELD. THIS LANGUAGE SHALL BE INCLUDED ON ALL PLANS, PLATS, ORDINANCES, SUBDIVISION INDENTURES AND OTHER APPROPRIATE (WRITTEN) DOCUMENTS FOR THIS DEVELOPMENT.

## SITE INFORMATION

LOCATOR NUMBERS: 19T220214, 19T210161  
PROPERTY ADDRESS: 1921, & 1925 WILSON AVENUE  
CHESTERFIELD, MO 63005  
EXISTING ZONING: R1 - RESIDENCE DISTRICT  
PROPOSED ZONING: P.U.D. PLANNED UNIT DEVELOPMENT  
GROSS AREA OF SITE: 17.37 ACRES  
DENSITY CALCULATIONS:  $17.37 \text{ AC} \times 43,560 \text{ SQ.FT./AC.} = 756,000 \text{ SQ.FT.}$   
 $(43,560 \text{ SQ.FT./LOT}) = 17 \text{ LOTS ALLOWED}$   
AVERAGE LOT SIZE: 24,232 S.F.  
MAXIMUM NUMBER OF UNITS ALLOWED: 17  
NUMBER OF UNITS PROPOSED: 16  
LOT DEVELOPMENT REQUIREMENTS:  
FRONT YARD SETBACK 25'  
SIDE YARD SETBACK 10'  
REAR YARD SETBACK 20'  
MIN. LOTS SIZE 22,000 SQ. FT.

NUMBER OF PARKING SPACES: TWO PER UNIT = 32 SPACES.

PROPOSED STREETS SHALL BE PRIVATE 26' WIDE PAVEMENT WITH 40' WIDE R.O.W.

DEEDED COMMON OPEN SPACE = 6.52 ACRES WHICH EQUALS 38% OF THE SITE.

COMMON GROUND = 0.23 ACRES WHICH EQUALS 1% OF THE SITE.

TOTAL TREE AREA = 4.44± ACRES

TOTAL TREES REQUIRED TO BE RETAINED = 1.33 ACRES (30% OF EXISTING TREE CANOPY)

TOTAL TREE AREA REMOVED = 3.11± ACRES

TOTAL TREE AREA RETAINED = 1.33 ACRES (APPROX. 30% OF EXISTING TREE CANOPY)

FLOOD MAP: FIRM NO. 29189C0164K DATED 02-04-15

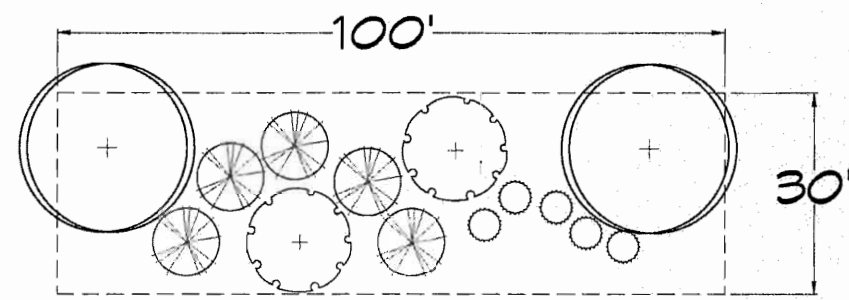

Typical 100' Section of  
Landscaped Buffer

- 2 - 2 1/2" Deciduous Canopy Trees
- 2 - 2 1/2" Flowering Trees
- 5 - 6" High Evergreen Trees
- 5 - 18" Evergreen Shrubs

\* Actual arrangement of plants may vary within each section to create a more natural feel.

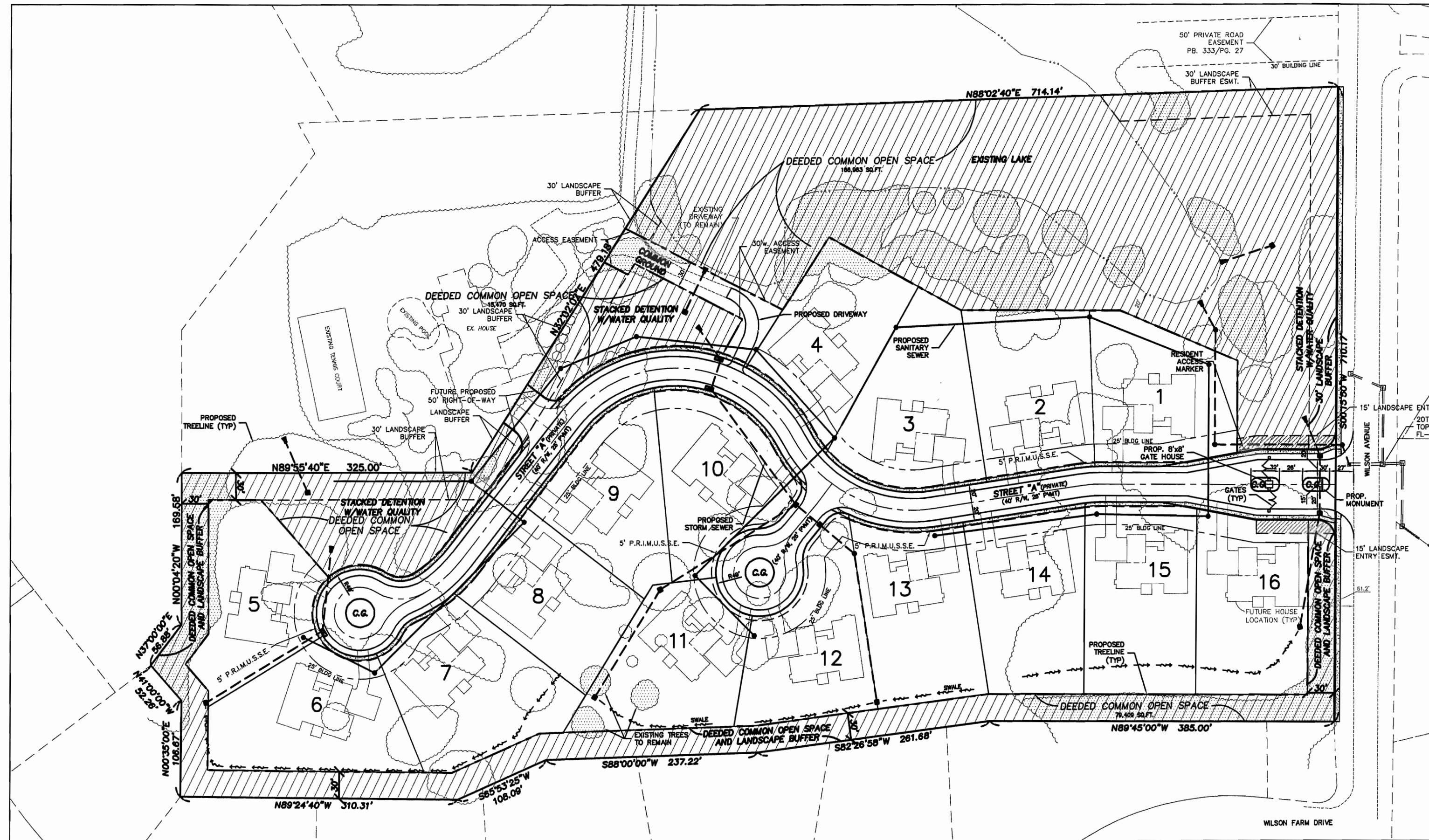

PROJECT ZIP CODE: 63005

## LEGAL DESCRIPTION:

A TRACT OF LAND BEING ALL OF LOTS 1 AND 1A OF "A RESUBDIVISION OF LOT 1 OF FALLING LEAVES ESTATES" ACCORDING TO THE PLAT THEREOF RECORDED IN PLAT BOOK 327, PAGE 88 OF SAID RECORDS, LOCATED IN SECTIONS 16 AND 21, TOWNSHIP 45 NORTH, RANGE 4 EAST OF THE FIFTH PRINCIPAL MERIDIAN, CITY OF CHESTERFIELD, ST. LOUIS COUNTY, MISSOURI AND BEING MORE PARTICULARLY DESCRIBED AS FOLLOWS: BEGINNING AT THE NORTHWEST CORNER OF ABOVE SAID LOT 1 OF SAID RESUBDIVISION, THENCE ALONG THE NORTH LINE OF SAID LOT 1, NORTH 88 DEGREES 02 MINUTES 40 SECONDS EAST, 714.14 FEET TO A POINT ON THE WEST LINE OF WILSON AVENUE, AS WIDENED, SAID POINT ALSO BEING THE NORTHEAST CORNER OF SAID LOT 1; THENCE LEAVING LAST SAID NORTH LINE AND ALONG THE WEST RIGHT-OF-WAY LINE OF SAID WILSON AVENUE, SOUTH 00 DEGREES 15 MINUTES 50 SECONDS WEST, 710.17 FEET TO THE SOUTHEAST CORNER OF SAID LOT 1, SAID CORNER ALSO BEING THE NORTHEAST CORNER OF COMMON GROUND OF "WILSON FARM ESTATES PLAT 1", A SUBDIVISION ACCORDING TO THE PLAT THEREOF RECORDED IN PLAT BOOK 217 PAGE 90 OF SAID RECORDS; THENCE LEAVING LAST SAID WEST RIGHT-OF-WAY LINE AND ALONG THE SOUTH LINE OF SAID LOT 1 AND ABOVE SAID LOT 1A, SAID LINE ALSO BEING THE NORTH LINE OF SAID "WILSON FARM ESTATES PLAT ONE" THE FOLLOWING COURSES AND DISTANCES: NORTH 89 DEGREES 45 MINUTES 00 SECONDS WEST, 385.00 FEET; SOUTH 82 DEGREES 26 MINUTES 58 SECONDS WEST, 261.68 FEET; SOUTH 88 DEGREES 00 MINUTES 00 SECONDS WEST, 237.22 FEET; SOUTH 65 DEGREES 53 MINUTES 25 SECONDS WEST, 108.09 FEET AND NORTH 89 DEGREES 24 MINUTES 40 SECONDS WEST, 310.31 FEET TO A POINT BEING THE SOUTHWEST CORNER OF SAID LOT 1A, SAID POINT ALSO BEING THE NORTHWEST CORNER OF LOT 130 OF SAID "WILSON FARM ESTATES PLAT ONE"; THENCE LEAVING LAST SAID LINE AND ALONG THE WEST LINE OF SAID LOT 1A THE FOLLOWING COURSES AND DISTANCES: NORTH 00 DEGREES 35 MINUTES 00 SECONDS EAST, 106.67 FEET; NORTH 41 DEGREES 00 MINUTES 00 SECONDS WEST, 52.26 FEET; NORTH 37 DEGREES 00 MINUTES 00 SECONDS EAST, 56.88 FEET; NORTH 00 DEGREES 04 MINUTES 20 SECONDS WEST, 169.58 FEET TO THE NORTHWEST CORNER OF SAID LOT 1A; THENCE WITH THE NORTH LINE OF SAID LOT 1A AND THE NORTHWEST LINE OF SAID LOT 1, NORTH 89 DEGREES 55 MINUTES 40 SECONDS EAST, 325.00 FEET; AND NORTH 32 DEGREES 02 MINUTES 02 SECONDS EAST, 479.18 FEET TO THE POINT OF BEGINNING AND CONTAINING 17.37 ACRES, MORE OR LESS ACCORDING TO RECORD INFORMATION AND SUBJECT TO THE RESULTS OF A FUTURE PROPERTY BOUNDARY SURVEY.

## SHEET INDEX

- 1.1 COVER SHEET
- 2.1 PRELIMINARY DEVELOPMENT PLAN
- 3.1 NATURAL RESOURCES MAP

## SURVEYORS CERTIFICATION

THIS IS TO CERTIFY THAT WE HAVE, DURING THE MONTH OF JANUARY, 2015, AT THE REQUEST OF FISCHER CUSTOM HOMES LLC., PREPARED A PRELIMINARY DEVELOPMENT PLAN OF "FALLING LEAVES ESTATES II", A TRACT OF LAND BEING A PART OF SECTIONS 16 & 21, TOWNSHIP 45 NORTH, RANGE 4 EAST, CITY OF CHESTERFIELD, ST. LOUIS COUNTY, MISSOURI. THIS PLAN IS NOT A SURVEY AND DOES NOT MEET THE "MISSOURI MINIMUM STANDARDS FOR PROPERTY BOUNDARY SURVEYS" (10 CSR 30-2 AND 4 CSR 30-16 EFFECTIVE DATE DECEMBER 30, 1994).

THE STERLING COMPANY

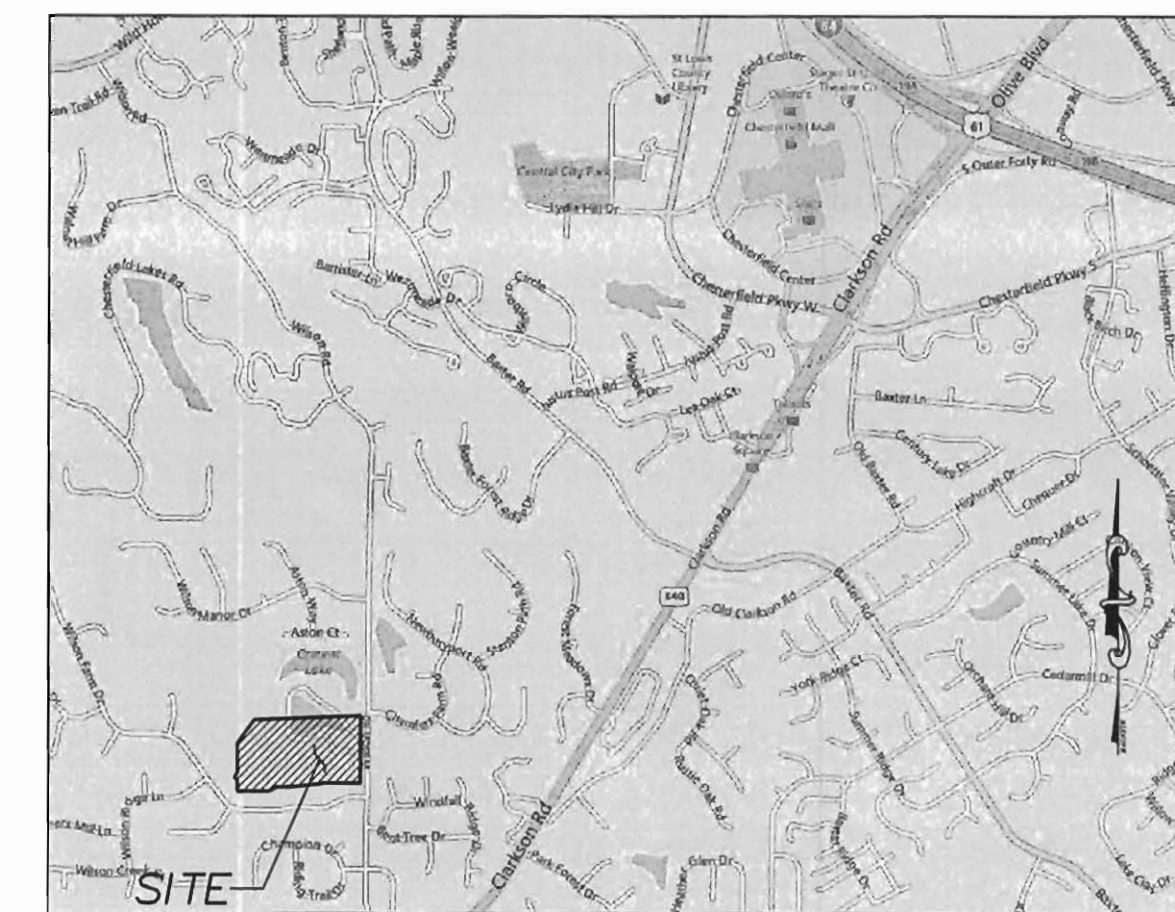
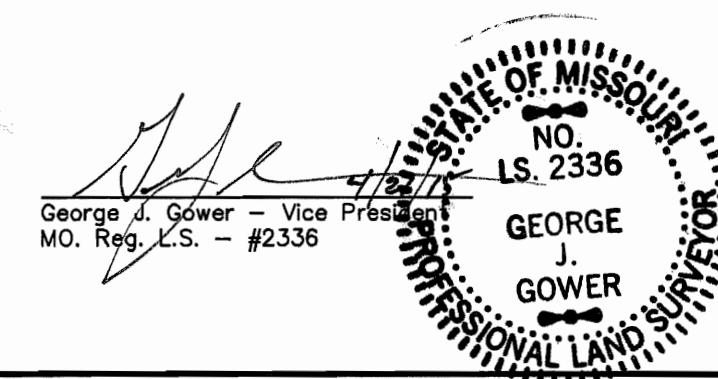

WUNNENBERG GRID - FF20 21  
LOCATION MAP  
N.T.S.

EXISTING	LEGEND	PROPOSED
542	CONTOURS	(542)
X 5% X 5% X 5%	SPOT ELEVATIONS	XXX.X
---	CENTER LINE	---
---	BUILDINGS, ETC.	---
---	TREE LINE	---
---	FENCE	---
---	SILTATION CONTROL FENCE	---
---	STORM SEWERS	---
---	SANITARY SEWERS	---
---	CATCH BASIN	---
---	AREA INLET	---
---	GRATED INLET	---
---	DOUBLE CURB INLET	---
---	STORM MANHOLE	---
---	SANITARY MANHOLE	---
---	FLARED END SECTION	---
---	CLEANOUT	---
---	LATERAL CONNECTION	---
---	UTILITY OR POWER POLE	---
---	FIRE HYDRANT	---
---	TEST HOLE	---
---	PAVEMENT	---
---	GAS MAIN & SIZE	---
---	WATER MAIN & SIZE	---
---	TELEPHONE	---
---	ELECTRIC (U) UNDERGROUND	---
---	ELECTRIC (O) OVERHEAD	---
---	FIBER OPTIC	---
---	FLOW LINE	---
---	TO BE REMOVED	TBR
---	TO BE REMOVED & RELOCATED/REPLACED	TBRR
---	TOP OF CURB	(TC)
---	SWALE	---
---	LIGHT STANDARD	---
---	STREET SIGN	---
---	PARKING STALLS	P.S.
---	YARD LIGHT	---

ISSUE	REMARKS/DATE
1	PRELIM DEV PLAN SUBMITTAL 01-19-15
2	REVISED PER CITY COMMENTS 02-03-15
3	REVISED PER CITY COMMENTS 03-24-15
4	REVISED PER CITY COMMENTS 04-07-15
5	REVISED PER CITY COMMENTS 04-20-15

Fischer Custom Homes LLC  
695 TRADE CENTER BLVD STE. 200  
CHESTERFIELD, MO 63005  
Ph. 314.576-0500  
Fax 314.576-0502

THE STERLING CO.  
ENGINEERS & SURVEYORS  
5055 New Baumgartner Road  
St. Louis, Missouri 63129  
Ph 314-487-0440 Fax 314-487-8944  
www.sterling-eng-sur.com  
Corporate Certificate of Authority #001348

Falling Leaves Estates II  
CHESTERFIELD, MISSOURI  
Preliminary Development Plan  
Cover Sheet

The Professional Engineer's seal and signature affixed to this sheet applies only to the material and items shown on this sheet. All drawing, instruments or other documents not including this seal and signature shall not be considered approved by the engineer. The engineer shall not be held responsible for any and all responsibility for such plans, drawings or documents not including this seal and signature.

Michael G. Boerding  
Professional Engineer  
License No. MO E-28643  
Civil Engineer

Job Number  
12-06-162  
Date  
Apr. 20, 2015  
Designed: MF Sheet  
Drawn: LG 1.1  
Checked: PRE

MSD Base Map - 19T, 20T

Attachment B

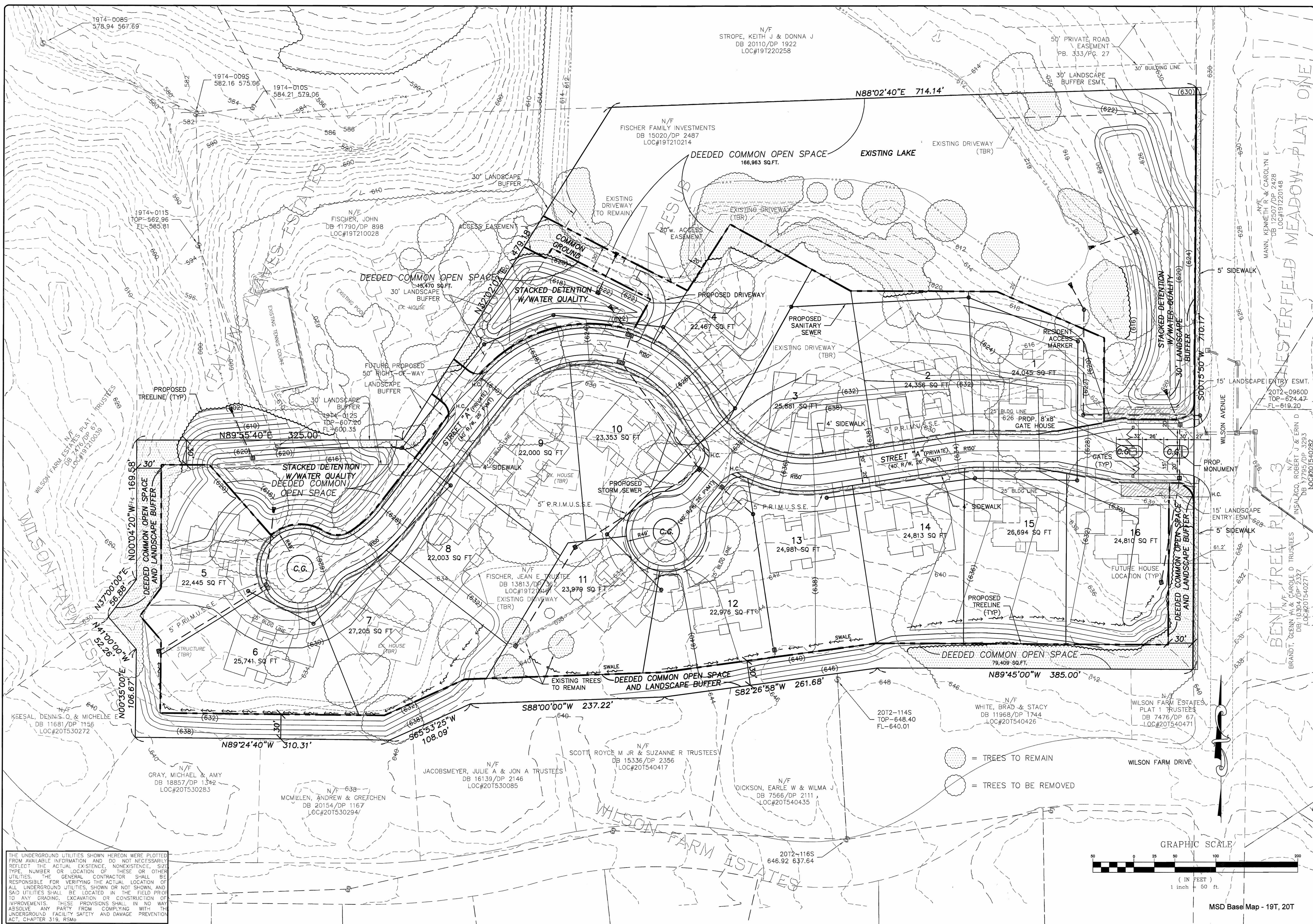

THE UNDERGROUND UTILITIES SHOWN HEREON WERE PLOTTED FROM AVAILABLE INFORMATION AND DO NOT NECESSARILY REFLECT THE ACTUAL EXISTENCE, NONEXISTENCE, SIZE, TYPE, NUMBER OR LOCATION OF THESE OR OTHER UTILITIES. THE GENERAL CONTRACTOR SHALL BE RESPONSIBLE FOR VERIFYING THE ACTUAL LOCATION OF ALL UNDERGROUND UTILITIES, SHOWN OR NOT SHOWN, AND SAID UTILITIES SHALL BE LOCATED IN THE FIELD PRIOR TO ANY GRADING, EXCAVATION OR CONSTRUCTION OF IMPROVEMENTS. THESE PROVISIONS SHALL IN NO WAY ABSOLVE ANY PARTY FROM COMPLYING WITH THE UNDERGROUND FACILITY SAFETY AND DAMAGE PREVENTION ACT, CHAPTER 319, RSMo.

ISSUE	REMARKS/DATE
1	PRELIM DEV PLAN SUBMITTAL 01-19-15
2	REVISED PER CITY COMMENTS 02-03-15
3	REVISED PER CITY COMMENTS 03-24-15
4	REVISED PER CITY COMMENTS 04-07-15
5	REVISED PER CITY COMMENTS 04-20-15

**Fischer Custom Homes LLC**  
 695 TRADE CENTER BLVD STE. 200  
 CHESTERFIELD, MO 63005  
 Ph. 314 576-0500  
 Fax 314 576-0502

**THE STERLING CO.**  
**ENGINEERS & SURVEYORS**  
 5055 New Baumgartner Road  
 St. Louis, Missouri 63129  
 Ph. 314-487-0440 Fax 314-487-8944  
 www.sterling-eng-survey.com  
 Corporate Certificate of Authority #001348

**Falling Leaves Estates II**  
 CHESTERFIELD, MISSOURI  
 Preliminary Development Plan

The Professional Engineer's seal and signature are shown to the right of this plan and are valid only for the project and area shown on this plan. All drawings, instruments or other documents not bearing the seal and signature are not to be considered as part of this plan. The Professional Engineer's seal and signature are required on all drawings and instruments and are required on all documents not bearing the seal and signature.

**Michael G. Boerding**  
 License No. MO E-28643  
 Civil Engineer

Job Number  
**12-06-162**  
 Date  
**Apr. 20, 2015**  
 Designed: MF Sheet  
 Drawn: LG **2.1**  
 Checked: PRE

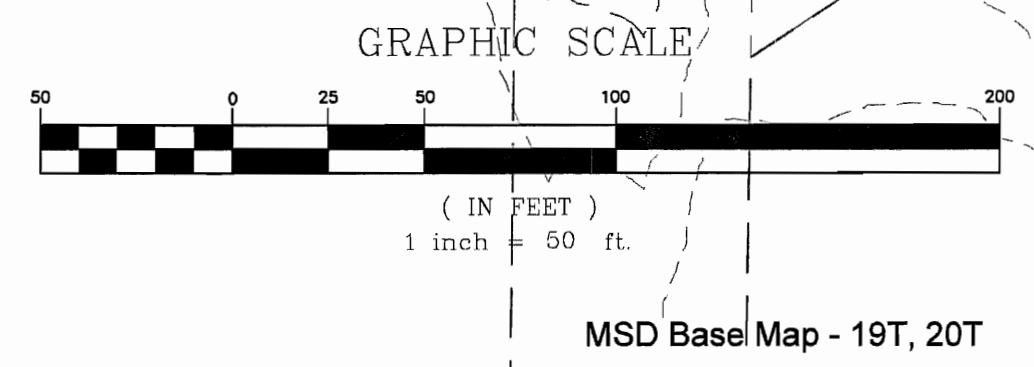

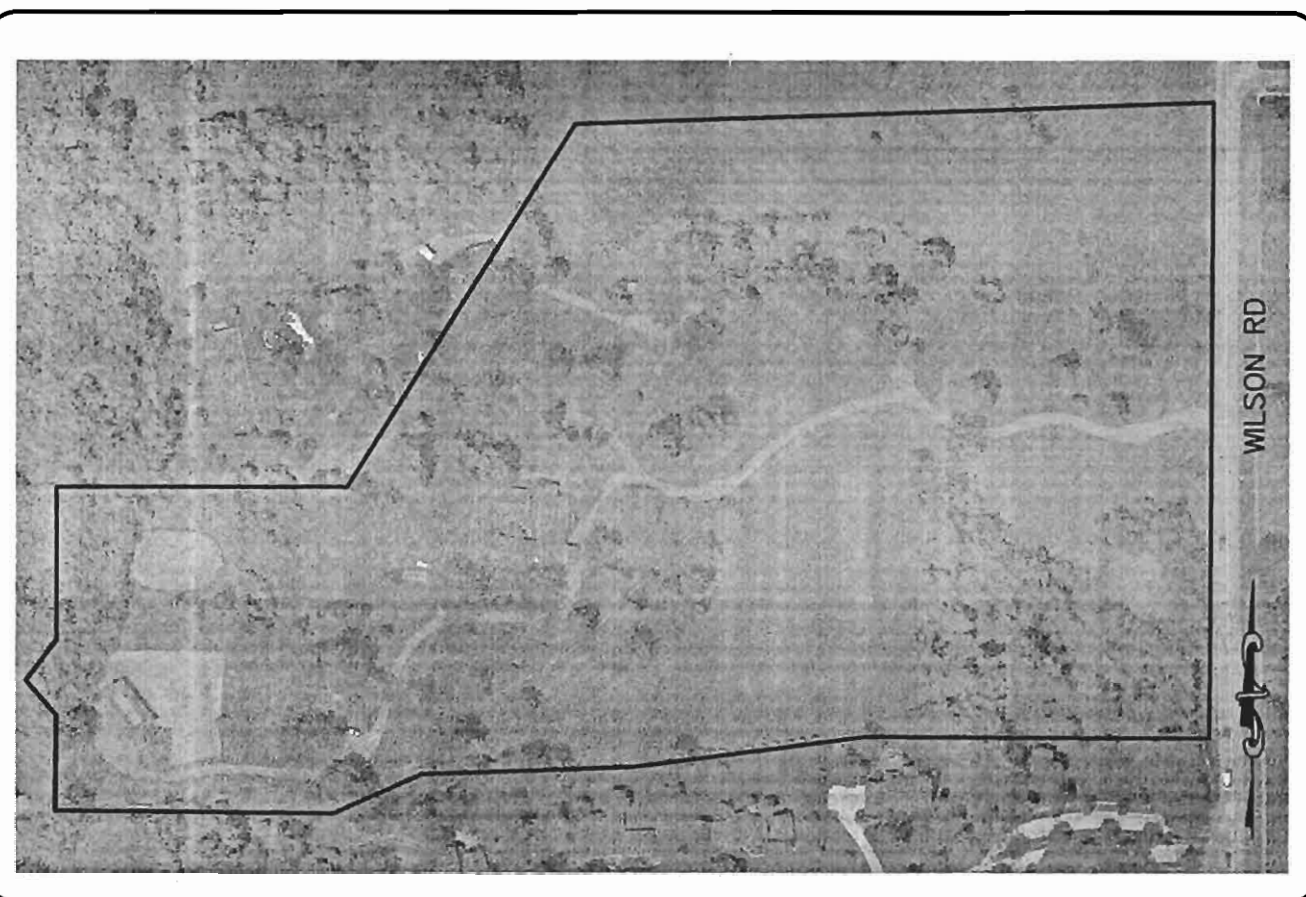

AERIAL PHOTO  
N.T.S.

Existing Tree Mass	
	Hydrologic Group "C" Soils
	Hydrologic Group "B" Soils
	Hydrologic Group "D" Soils
	Areas of Slopes in Excess of 20%
	Regulated Waters

NATURAL RESOURCE	PRESENCE	ADDITIONAL INFORMATION
Wetlands	No	None identified during site walk.
Streams and Floodplains	Yes	Drainage ditch located one on the West side and one on the East side of the site.
Karst	No	None identified during site walk.
Ponds/Lakes	Yes	One lake located at the North side and one pond at the East side of the site.

**SITE INFORMATION:**

SURROUNDING PROPERTY USES: RESIDENTIAL  
EXISTING USE: RESIDENTIAL

THE UNDERGROUND UTILITIES SHOWN HEREON WERE PLOTTED FROM AVAILABLE INFORMATION AND DO NOT NECESSARILY REFLECT THE ACTUAL EXISTENCE, NONEXISTENCE, SIZE, TYPE, NUMBER OR LOCATION OF THESE OR OTHER UTILITIES. THE GENERAL CONTRACTOR SHALL BE RESPONSIBLE FOR VERIFYING THE ACTUAL LOCATION OF ALL UNDERGROUND UTILITIES SHOWN OR NOT SHOWN, AND SAID UTILITIES SHALL BE LOCATED IN THE FIELD PRIOR TO ANY GRADING, EXCAVATION OR CONSTRUCTION OF IMPROVEMENTS. THESE PROVISIONS SHALL IN NO WAY ABSOLVE ANY PARTY FROM COMPLYING WITH THE UNDERGROUND FACILITY SAFETY AND DAMAGE PREVENTION ACT, CHAPTER 319, RSMo.

ISSUE	REMARKS/DATE
1	PRELIM DEV PLAN SUBMITTAL 01-19-15
2	REVISED PER CITY COMMENTS 02-03-15
3	REVISED PER CITY COMMENTS 03-24-15
4	REVISED PER CITY COMMENTS 04-07-15
5	REVISED PER CITY COMMENTS 04-20-15

**Fischer Custom Homes LLC**  
685 TRADE CENTER BLVD STE. 200  
CHESTERFIELD, MO 63005  
Ph. 314.576.0500  
Fax 314.576.0502

**THE STERLING CO.**  
**ENGINEERS & SURVEYORS**  
5055 New Baumgartner Road  
St. Louis, Missouri 63129  
Ph 314-487-0440 Fax 314-487-8944  
www.sterling-eng-sur.com  
Corporate Certificate of Authority #001948

**Falling Leaves Estates II**  
CHESTERFIELD, MISSOURI  
Preliminary Development Plan  
Natural Resources Map

The Professional Engineer's seal and signature affixed to this sheet are valid only to the extent and for the purposes set forth in the Missouri Statutes. The Professional Engineer shall not be considered to have approved any other documents or drawings unless they are specifically identified on this sheet. The Professional Engineer shall not be held responsible for any errors or omissions on this sheet or any other documents or drawings unless they are specifically identified on this sheet.

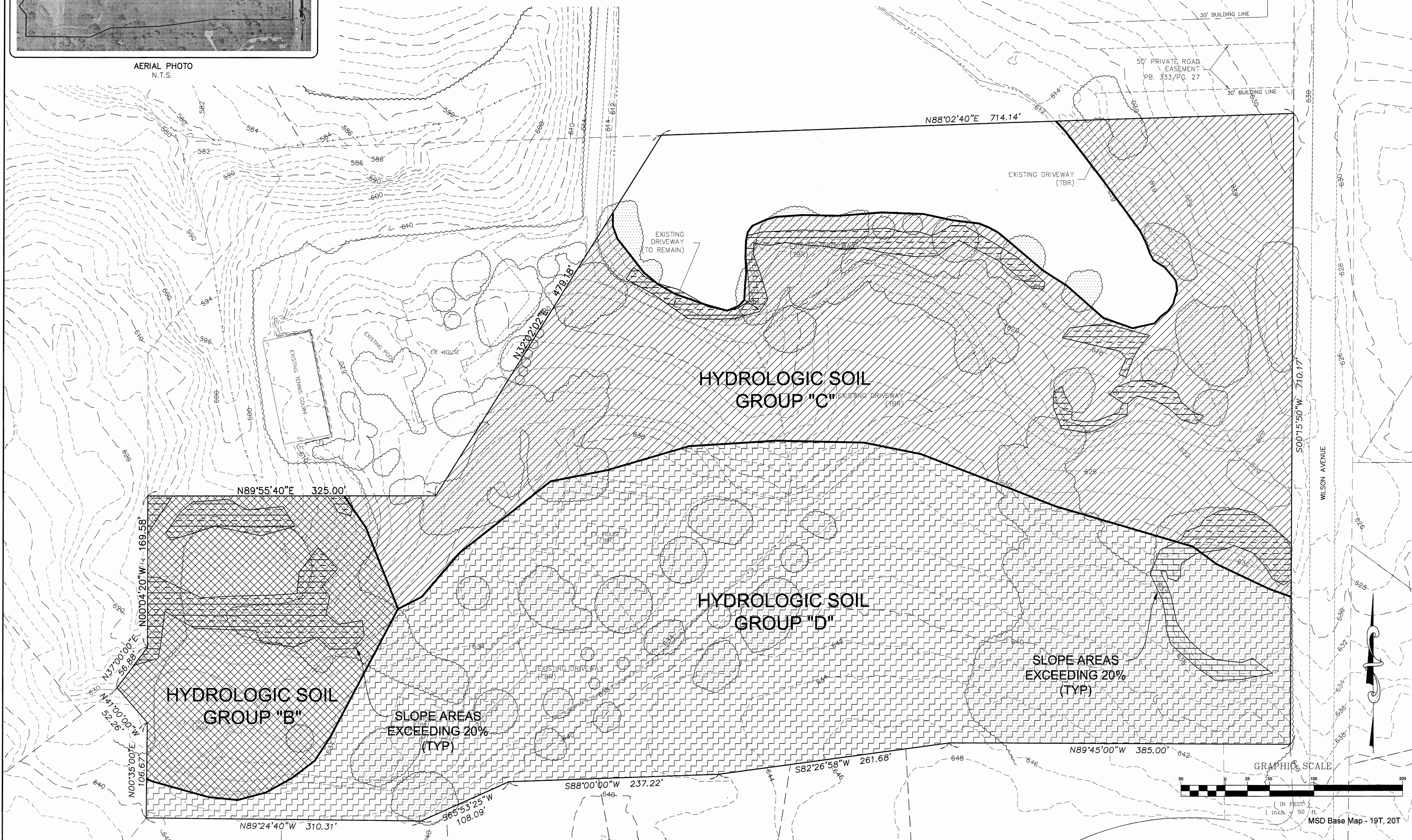

Date: 04-20-15  
MICHAEL G. BOERDING  
License No. MO E-28843  
Civil Engineer

Job Number  
**12-06-162**  
Date  
**Apr. 20, 2015**  
Designed: MF Sheet  
Drawn: LG **3.1**  
Checked: JG PRE



Drawing name: C:\TEMP\publish\_67868616309RE.dwg Plot date: Apr 21, 2015 - 7:51 am Plotted by: jgreen

Legend:

-  Existing tree or tree mass
-  Existing monarch tree
-  BAF Sample Point

Monarch Trees

Tree#	Species	dbh	Cond
M1	E. Redcedar	20	Fair
M2	E. Redcedar	20	Fair
M3	Silver Maple	30	Fair
M4	Silver Maple	37	Fair
M5	Silver Maple	20	Fair
M6	White Pine	23	Good
M7	Spruce spp.	25	Fair
M8	Basswood	20x20x24	Fair
M9	Pin Oak	30	Fair
M10	Sugar Maple	25	Fair
M11	White Pine	22	Fair
M12	White Pine	28	Fair
M13	Pin Oak	25	Fair
M14	White Pine	37	Fair
M15	Black Cherry	22	Fair
M16	White Pine	25	Fair
M17	Ash	29	Fair
M18	Sycamore	25	Fair
M19	Ash	32	Fair
M20	Sycamore	26	Fair
M21	White Pine	24	Fair
M25	Pin Oak	29	Fair
M26	Pin Oak	26	Fair
M27	Tulip Poplar	20	Fair
M28	White Pine	23	Fair
M29	Ash	23	Fair
M30	Pin Oak	29	Fair
M31	Red Oak	25	Fair
M32	Sugar Maple	22	Fair
M33	River Birch	23	Fair
M34	Silver Maple	27	Fair
M35	Silver Maple	28	Fair
M36	Silver Maple	40	Fair
M37	Silver Maple	24	Fair
M38	Silver Maple	40	Fair
M39	Pin Oak	26	Fair
M40	Sweetgum	22	Fair
M41	River Birch	27	Fair
M42	Silver Maple	25	Fair
M43	Pin Oak	29	Fair
M44	Sweetgum	23	Fair
M45	Ash	31	Fair
M46	Pin Oak	22	Fair
M47	Sweetgum	20	Fair
M48	Sweetgum	21	Fair
M49	Sugar Maple	25	Fair
M50	Pin Oak	31	Fair
M51	Red Oak	28	Fair
M52	Catalpa	27	Fair

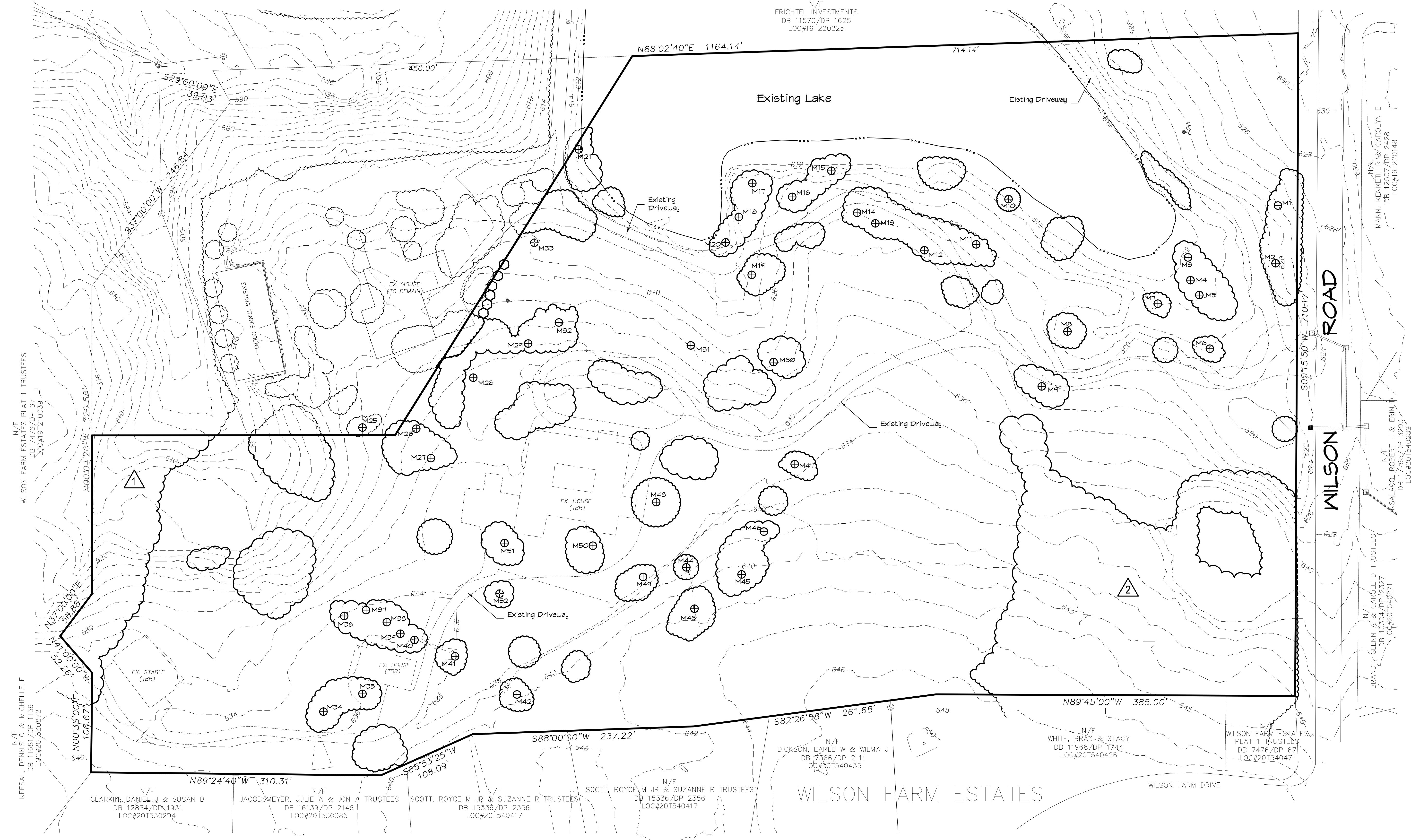

Tree Preservation Calculations:

1. Size of Tract: 17.37 acres (±)
2. Existing tree canopy: 4.44 acres (±)
3. Trees required to be retained: 1.33 acres (30% of existing tree canopy)
4. Source of Base Information: Outboundary, topographic and preliminary engineering information obtained from available records, and as provided by The Sterling Company Engineers Surveyors.

Sample Point Information

Tree#	Species	dbh	Cond	Comments
1	Hackberry	7"	Fair	BAF Point 1
2	Hackberry	8x11x12"	Poor	BAF Point 1
3	Hickory	6"	Poor	BAF Point 1
4	Hackberry	6"	Fair	BAF Point 1
5	Hackberry	11"	Fair	BAF Point 1
6	Post Oak	18"	Fair	BAF Point 1
7	Hackberry	9"	Fair	BAF Point 1
8	Hackberry	10"	Fair	BAF Point 1
9	Elm	8"	Dead	BAF Point 1
10	Elm	10"	Dead	BAF Point 1
11	White Oak	37"	Fair	BAF Point 1
12	Hickory	12"	Fair	BAF Point 1
13	Hickory	14"	Fair	BAF Point 1
14	Hackberry	13x14x15"	Fair	BAF Point 1
M15	White Oak	30"	Fair	BAF Point 1
M16	White Oak	39"	Fair	BAF Point 1
1	Red Maple	18"	Very Poor	BAF Point 2
2	Elm	11"	Poor	BAF Point 2
3	Red Maple	15"	Poor	BAF Point 2
4	White Pine	23"	Fair	BAF Point 2
5	Silver Maple	64"	Poor	BAF Point 2
6	Red Maple	8"	Very Poor	BAF Point 2
7	Mulberry	16"	Very Poor	BAF Point 2

BAF Point 1		
Elm	2	13%
Hackberry	7	44%
Hickory	3	19%
Post Oak	1	6%
White Oak	3	19%

BAF Point 2		
Silver Maple	1	14%
Elm	1	14%
White Pine	1	14%
Red Maple	3	43%
Mulberry	1	14%

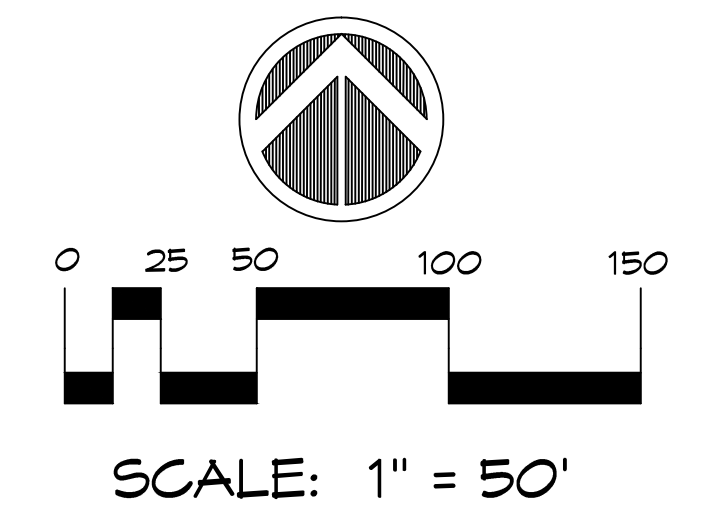

Prepared for:

**FISCHER & FRICHTEL CUSTOM HOMES, LLC.**  
 695 Trade Center Boulevard  
 Suite 200  
 Chesterfield, Missouri 63005

Arborist/Forester:

Bruce Vauter  
 Forestry Consultant Services  
 9321 Manor Oak Drive  
 St. Louis, Missouri 63126  
 314/849-2753  
 Certified Arborist: # MW-0469A  
 Certified Forester: # 2501

*Bruce Vauter*

Falling Leaves Estates II  
 Tree Stand Delineation

 **HALL + ASSOCIATES, L.L.C.**  
 LAND PLANNING  
 LANDSCAPE ARCHITECTURE

424 SOUTH CLAY AVENUE, ST. LOUIS, MO 63122 314.966.5577

Drawn by: JRH	Checked by:	Project Number: 13004	Sheet Number: 1 OF 1
Date: 1-14-15			
Revisions: 3-23-15			